

A Novel Current-Mode Multifunction Inverse Filter using Single CFA



Anisur Rehman Nasir, S. N. Ahmad

Abstract: A novel current-mode multifunction inverse filter configuration using single current feedback amplifier (CFA) is presented. The proposed filter employs only one CFA and few passive components. The proposed circuit realizes inverse lowpass, inverse bandpass and inverse highpass filter functions with proper admittances. The characteristics of proposed multifunction inverse filter configuration are- current-mode realization; use of only one CFA; use of grounded passive components except one virtually grounded and realizing all three basic inverse filters. The proposed current-mode inverse filter circuit has been tested by TINA PRO simulation program and results justified the theoretical analysis.

Keywords: Current Feedback Amplifier, Current-mode, Voltage Mode, Multifunction, Inverse Filter, Admittances.

I. INTRODUCTION

This design of analog inverse filter is useful in communication, control and instrumentation engineering. The inverse filters are used to reverse the distortion of signal incurred due to signal processing and transmission. The distorted signal is to be converted to the input signal. The inverse filtering is a technique to invert the transfer characteristic of the original signal [1, 2]. In digital signal processing, various techniques are used to realize digital inverse filters [2]. However, few circuits are reported in literature for realization of analog inverse filters [3, 15-32]. Most of the inverse filter circuits reported in literature are voltage-mode circuit. The voltage mode inverse filters are realized mostly by current feedback amplifier (CFAs), current conveyor (CCII), current differencing buffered amplifier (CDBAs), operational trans resistance amplifier (OTRA) and operational transconductance amplifier (OTAs) [18,19,21,22,24,26-32]. The current-mode technique has several advantages such as higher bandwidth, large dynamic range, low power consumption, greater linearity and simpler circuitry. The current feedback amplifiers have found wide application in the design of active filters and oscillators due to several advantages like high slew rate, constant bandwidth and also commercially available [4-14].

The inverse filters in current-mode have been realized using four terminal floating nullors (FTFNs) [15-17], current differencing transconductance amplifier (CDTA) [20] and current differencing buffered amplifier (CDBA) [23] respectively. There are many reports by several researchers on analog inverse filters. In [3], a general method has been proposed for realizing inverse filter using nullors. Chipipop and Surakamponorn [15] gave procedure for current-mode four terminal floating nullor (FTFN) based inverse filter from voltage mode inverse filter. Wang and Lee [16] proposed current-mode inverse filters using FTFNs. Abuelmatti [17] employed one FTFN to obtain current-mode inverse lowpass, highpass and bandpass filters. A voltage mode inverse filter was implemented using current feedback operational amplifiers (CFOA) which realize inverse lowpass, bandpass, and highpass and bandreject filter configurations [18]. A voltage mode inverse multifunction filter using three CFOAs and passive components was proposed [19]. Shah, Quadri and Iqbal [20] proposed inverse all pass filter using current differencing transconductance amplifier (CDTA). A current conveyor (CCII) based inverse filter was realized [21]. Pandey, Pandey, Negi and Garg [22] presented voltage mode inverse filters using two current differencing buffered amplifiers (CDBAs). Nasir and Ahmad [23] proposed current-mode multifunction inverse filter using CDBA which realizes inverse lowpass, high pass and band pass filters. An inverse filter realized using DDCCs and minimum passive components [24]. Three modified current feedback operational amplifiers (MOCFOA) and five admittances are employed to obtain inverse lowpass, bandpass and highpass filters [25]. Tsukutani, Sumi and Yabuki [26] realized inverse lowpass highpass and bandpass filters using five or six multiple output operational transconductance amplifiers (MOTA). Patil and Sharma [27] used two CFOAs to obtain inverse filter. A multifunction inverse filter was presented using three current conveyors (CCII) and four or five admittances [28]. Singh, Gupta and Senani proposed operational transresistance amplifiers (OTRA) based inverse low pass, high pass and bandpass filters in voltage mode [29]. Pradhan and Sharma realized OTRA based inverse all pass and inverse band reject filters [30]. A multifunction inverse filter was reported using two CDBAs and passive components [31]. A voltage-mode analog inverse filter using three OTAs and two fractional capacitors (FCs) realized fractional inverse filters [32].

The review of the reported works in literature reveals that no inverse filter in current-mode employing a single CFA has been presented. Therefore, the main objective of this paper is to propose a novel current-mode multifunction inverse filter using only one CFA and five admittances.

Manuscript received on June 16, 2021.

Revised Manuscript received on June 21, 2021.

Manuscript published on June 30, 2021.

* Correspondence Author

Anisur Rehman Nasir*, Department of Electronic Engineering, Engineering and Technology, Jamia Millia Islamia, New Delhi, India. E-mail: anasir@jmi.ac.in

S. N. Ahmad, Department of Electronics & Communication Engineering, Engineering, Engineering and Technology, Jamia Millia Islamia, New Delhi, India. Email: snahmad@jmi.ac.in

© The Authors. Published by Blue Eyes Intelligence Engineering and Sciences Publication (BEIESP). This is an open access article under the CC BY-NC-ND license (<http://creativecommons.org/licenses/by-nc-nd/4.0/>)



By proper selection of admittances, inverse lowpass, inverse bandpass and inverse highpass filter functions can be realized from the same configuration. The use of one CFA is new to available inverse filter circuits. The simulation results are in agreement with theoretical analysis. A comparative analysis of inverse filters is given in Table-1. It is noted that the proposed circuit is using single CFA

II. CIRCUIT DESCRIPTION

The symbol of CFA circuit has been shown in Fig.1. The port relations of a CFA can be characterized by the following Eq. (1):

$$V_x = V_y, I_x = I_z, I_y = 0 \text{ and } V_z = V_o \quad (1)$$

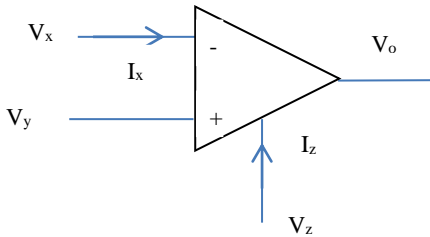

Fig.1. Circuit symbol of CFA

The current-mode multifunction inverse filter proposed circuit is shown in Fig. 2. The routine analysis of circuit yields the current transfer functions as follows:

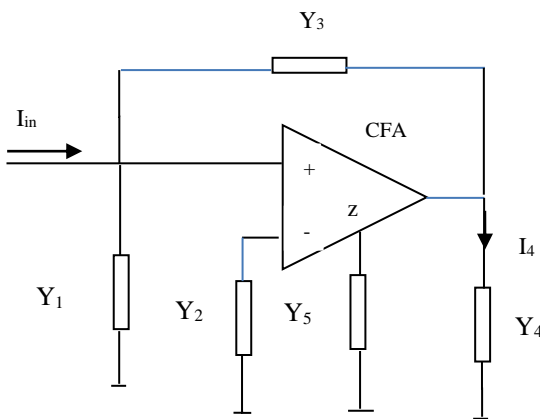

Fig. 2. Proposed circuit of CM inverse filter

$$\frac{I_4}{I_{in}} = \frac{N(s)}{D(s)} = \frac{Y_2 Y_4}{Y_1 Y_5 + Y_3 Y_5 - Y_2 Y_3} \quad (2)$$

where

$$N(s) = Y_2 Y_4$$

$$D(s) = Y_1 Y_5 + Y_3 Y_5 - Y_2 Y_3$$

If admittances chosen are \$Y_2 = sC_2 + G_2\$, and

\$Y_4 = sC_4 + G_4\$, then

$$N(s) = (sC_2 + G_2)(sC_4 + G_4)$$

$$N(s) = S^2 C_2 C_4 + s(C_2 G_4 + C_4 G_2) + G_2 G_4 \quad (3)$$

The transfer function of inverse lowpass (ILP) filter can be obtained by choosing the admittances as \$Y_1 = G_1, Y_2 = sC_2 +\$

\$G_2, Y_3 = 0, Y_4 = sC_4 + G_4, Y_5 = G_5\$. The resulting function of inverse lowpass filter is given by Eq. (4):

$$\frac{I_4}{I_{in}} = \frac{1}{G_1 G_5 / (s^2 C_2 C_4 + s(C_2 G_4 + C_4 G_2) + G_2 G_4)} \quad (4)$$

The transfer function of inverse highpass (IHP) filter can be obtained by choosing the admittances as \$Y_1 = sC_1, Y_2 = sC_2 + G_2, Y_3 = 0, Y_4 = sC_4 + G_4, Y_5 = sC_5\$. The resulting function of inverse highpass filter is given by Eq. (5):

$$\frac{I_4}{I_{in}} = \frac{1}{s^2 C_1 C_5 / (s^2 C_2 C_4 + s(C_2 G_4 + C_4 G_2) + G_2 G_4)} \quad (5)$$

The transfer function of inverse highpass (IHP) filter can be obtained by choosing the admittances as \$Y_1 = sC_1, Y_2 = sC_2 + G_2, Y_3 = 0, Y_4 = sC_4 + G_4, Y_5 = sC_5\$. The resulting function of inverse highpass filter is given by Eq. (5):

$$\frac{I_4}{I_{in}} = \frac{1}{s^2 C_1 C_5 / (s^2 C_2 C_4 + s(C_2 G_4 + C_4 G_2) + G_2 G_4)} \quad (5)$$

Similarly, the transfer function of inverse bandpass (IBP) filter can be obtained by choosing the admittances as \$Y_1 = sC_1, Y_2 = sC_2 + G_2, Y_3 = 0, Y_4 = sC_4 + G_4, Y_5 = G_5\$. The resulting function of inverse bandpass filter is given by Eq. (6):

$$\frac{I_4}{I_{in}} = \frac{1}{s C_1 G_5 / (s^2 C_2 C_4 + s(C_2 G_4 + C_4 G_2) + G_2 G_4)} \quad (6)$$

The natural angular frequency (\$\omega_o\$) and the pole (Q) of the filter is:

$$\omega_o = \sqrt{\frac{G_2 G_4}{C_2 C_4}} \quad (7)$$

$$Q = \frac{\sqrt{C_2 C_4 G_2 G_4}}{(C_2 G_4 + C_4 G_2)} \quad (8)$$

The gain constants of ILP, IHP and IBP responses are given by:

$$H_{ILP} = \frac{G_1 G_5}{G_2 G_4}$$

$$H_{IHP} = \frac{C_1 C_5}{C_2 C_4}$$

$$H_{IBP} = \frac{C_1 G_5}{C_2 G_4 + C_4 G_2}$$

Table-I Comparison of proposed inverse filter with previously reported work

No. of Active Elem.	No. of Passive Elem.	Mode	No. of filter realized	Ref.
1 Nullor	2-C,4-R	VM	IHP	[3]
1 FTFN	2-C,5-R	CM	ILP	[15]
1 FTFN	2-C,4-R	CM	IAP	[16]
1 FTFN	3-C,4-R	CM	ILP, IHP, IBP, IBR, IAP	[17]
3 CFA	2-C,5-R	VM	ILP, IHP, IBP, IBR	[18]



3 CFA	3-C,3-R	VM	ILP, IHP, IBP	[19]
1 DTA	1-C,1-R	CM	IAP	[20]
1 CCII	1-C,,2-R	VM	IAP	[21]
2 CDBA	4-C,2-R	VM	ILP, IHP, IBP, IBR, IAP	[22]
2 CDBA	3-C,3-R	CM	ILP, IHP, IBP	[23]
3 DDCC	2-C,2-R	VM	ILP, IBP, IHP	[24]
3 CFA	4-C,3-R	VM	ILP, IBP, IHP	[25]
12 OTAs	2-C	VM-CM	ILP, IHP, IBP	[26]
2 CFA	2-C,6-R	VM	ILP, IHP, IBP, IBR	[27]
3 CCII	4-5C,5-R	VM	IHP, IBP,ILP	[28]
2 OTRA	3-C,4-R	VM	ILP, IHP, IBP	[29]
2OTRA	4-C,5-R	VM	IAP,IBR	[30]
2CDBA	3-C,4-R	VM	ILP, IHP, IBP	[31]
3OTA	2-C	VM	ILP, IHP, IBP	[32]
1 CFA	4-C,4-R	CM	ILP, IHP, IBP	Proposed

III. NON-EQUIVALENT CIRCUIT OF CFA

Fig.3. shows the non-ideal equivalent circuit model of the CFA. R_x is the input resistance of the x-terminal, $R_y // (1/sC_y)$ represents the y-terminal parasitic input impedance, $R_p // (1/sC_p)$ at the compensation terminal z [7]. The values of the various parasitics for the bipolar CFAs (AD844) are $R_x=50\Omega$, $C_p=5.5pF$, $R_p= 3M\Omega$, $R_y=2M\Omega$ and $C_y=2pF$.

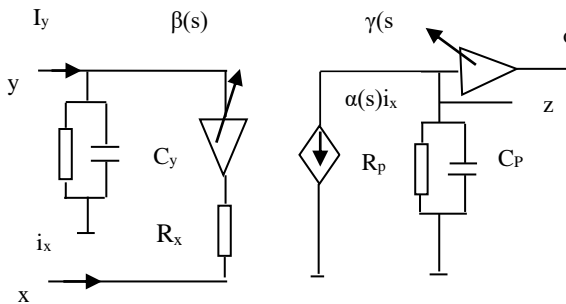

Fig.3. Non-ideal equivalent circuit of the CFA includes the parasitic impedances

IV. SENSITIVITY ANALYSIS

Taking into account the tracking errors of current feedback amplifier, the terminal equation (1) get modified as equation (9):

$$I_z = \alpha I_x, \quad V_x = \beta V_y, \quad \text{and} \quad V_o = \gamma V_z \quad (9)$$

where $\alpha = 1 - \epsilon_1$ ($|\epsilon_1| \ll 1$) denotes the current tracking error, $\beta = 1 - \epsilon_2$ ($|\epsilon_2| \ll 1$) is the input voltage tracking error and $\gamma = 1 - \epsilon_3$ ($|\epsilon_3| \ll 1$) is the output voltage tracking error of the current feedback amplifier.

The passive sensitivities of ω_o and Q for the proposed current-mode inverse filter can be expressed as:

$$S_{G_2}^{\omega_o} = S_{G_4}^{\omega_o} = -S_{C_2}^{\omega_o} = -S_{C_4}^{\omega_o} = \frac{1}{2}$$

$$S_{G_2}^Q = S_{C_4}^Q = \frac{1}{2} - \frac{C_4 G_2}{C_4 G_2 + C_2 G_4}$$

$$S_{G_4}^Q = S_{C_2}^Q = \frac{1}{2} - \frac{C_2 G_4}{C_4 G_2 + C_2 G_4}$$

It is observed that the passive sensitivities are less than unity in magnitude. Hence, the performances of proposed current-mode inverse filters are not affected.

V. SIMULATION RESULT

The proposed current-mode inverse filter has been simulated with TINA PRO software. The inverse filter has been designed for $f_o = 796.18 \text{ KHz}$ and $Q = 1$.

The CFA has been realized with available IC AD 844. The equal values of passive components are used. The supply voltages are $\pm 12V$. All the resistors are taken as $10K\Omega$ and capacitors as $20pF$. The simulated frequency characteristics for inverse lowpass, inverse bandpass and inverse highpass filter functions are shown in Fig.4. The simulation results agree well with theoretical analysis of the inverse filter.

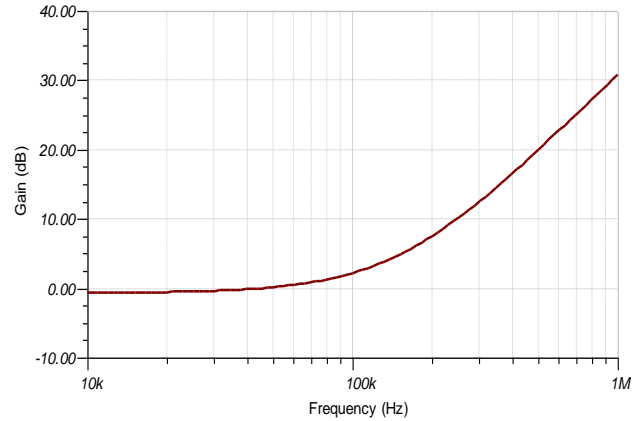

(a) Inverse Lowpass Filter

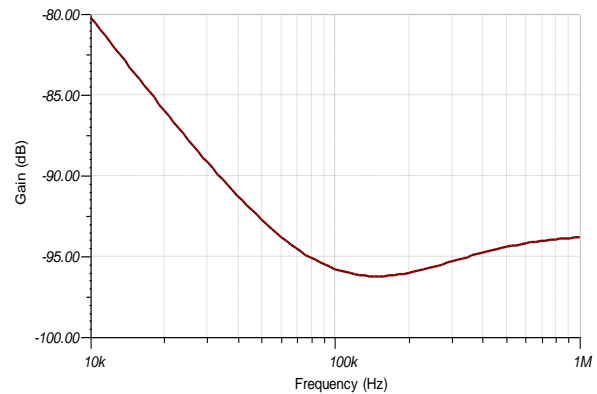

(b) Inverse Bandpass Filter

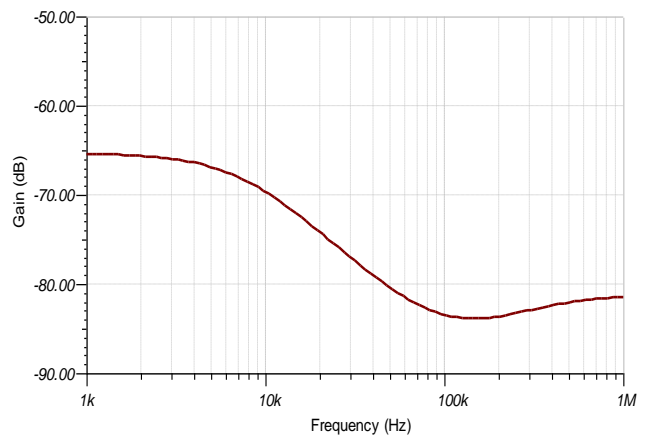

(c) Inverse Highpass Filter

Fig.4. Frequency Response of Inverse Filters



VI. CONCLUSIONS

A novel current-mode multifunction inverse filter using one CFA has been presented. The proposed circuit uses one CFA and five admittances. The inverse lowpass, inverse bandpass and inverse highpass filter functions are realized by proper selection of admittances. The proposed inverse filters have the advantages of using only one CFA and all grounded passive components except one virtually grounded. The simulation results are in agreement with theoretical analysis. The use of single CFA is a new configuration to inverse filter circuits available in literature.

REFERENCES

- J. K. Tugnait, "Identification and deconvolution of multichannel linear non-Gaussian processes using higher order statistics and inverse filter criteria", *IEEE Transactions on Signal Processing*, 45 (3), (1997), 658–672.
- G. J. Proakis and G.D. Manolakis, "Introduction to Digital Signal Processing", Prentice Hall, New York, 4th edition, 2007.
- A. Leuciuc, "Using nullors for realisation of inverse transfer functions and characteristics", *Electronics Letters*, 33(11), (1997), 949-951. <http://dx.doi.org/10.1049/el:19970637>
- S.I. Liu, "High input impedance filters with low component spread using current-feedback amplifiers", *Electronics Lett.*, 31(13), (1995), 1042-1043.
- R. K. Sharma and R. Senani, "Universal current mode biquad using a single CFOA", *Int. J. Electronics*, 91(3), (2004), 175–183.
- N. A. Shah, M.F. Rather and S.Z. Iqbal, "Current-mode universal filter using CFAs", *Indian J. Pure and Applied Physics*, 42, (2004), 375-377.
- A. R. Nasir and S.N. Ahmad, "Minimum Component Current-mode universal Filter using Current Feedback Amplifier", *Int. Conf. on Advance Computing & Com.Technologies*, (2008), 611-612,
- S.N. Ahmad, M.R. Khan and Moinuddin, "A new current-mode universal filter", *Frequenz*, 7(8), (2004), 195-196.
- S. S. Gupta, D. R. Bhaskar and R. Senani, "New Voltage controlled oscillators using CFOAs", *Int. J. Electron Commun AEU*, 63(3), (2009), 209-217.
- A. R. Nasir and S.N. Ahmad, "Current-mode multifunction filter using current feedback amplifiers and grounded capacitors", *Nat. Conf. on Computing for Nation's Developments, INDIACOM- 2011*, (2011), 579- 580.
- J. W. Horng, C.L Hou, W. S. Huang, and D. Yang, "Voltage/ Current -mode multifunction filters using one current feedback amplifier and grounded capacitors", *Circuits and Systems*, 2(2), (2011), 60-64.
- S. N. Ahmad and A. R . Nasir , "A new CFA based current-mode universal biquad filter", *American J. of Electrical and Electronic Engineering*, 2(2), (2014), 48-50.
- A. R. Nasir , "A new current-mode second order universal filter employing current feedback amplifiers and grounded capacitors", *J. of Multidisciplinary Engg. Science Studies*, 1 (2), (2015), 170-172.
- A. R. Nasir, "New current feedback amplifier based current-mode second order universal biquadratic filter," *Kasmera Journal*, 44(2), 2016, 143-150.
- B. Chipipop and W. Surakampon, "Realisation of current-mode FTFN-based inverse filter", *Electronics Letters*, 35(9), (1999), 690-692.
- H. Y. Wang and C. T. Lee, "Using nullors for realisation of current-mode FTFN-based inverse filters". *Electronics Letters*, 35 (22), (1999), 1889-1890. <http://dx.doi.org/10.1049/el:19991336>
- M. T. Abuelma'ati, "Identification of cascadable current-mode filters and inverse filters using single FTFN", *Frequenz*, 54(11), (2000), 284-289.
- S. S. Gupta, D. R .Bhaskar and R. Senani, "New analogue inverse filters realised with current-feedback op- amp", *Int. Journal of Electronics*, 98(8), (2011), 1103–1113.
- H. Y. Wang, S.H.Chang, T. Y. Yang and P.Y. Tsai, "A novel multifunction CFOA-based inverse filter", *Circuits and Systems*, 2, (2011), 14-17. <https://doi.org/10.4236/cs.2011.21003>
- N.A. Shah, M.Quadri and S.Z.Iqbal, "High output impedance current-mode all pass inverse filter using CDTA", *Indian J. of Pure and Applied Physics*, 46(12), (2008), 893–896.

- N.A. Shah and M. F. Rather, "Realization of voltage-mode CCII based allpass filter and its inverse inversion", *Indian J. of Pure and Applied Physics*, 44(3), (2006), 269-271.
- R. Pandey, N. Pandey, T. Negi and. Garg, " CDBA based universal inverse filter", *ISRNElectronics2013*. <https://doi.org/10.1155/2013/181869>
- A. R. Nasir and S. N. Ahmad, "A new current-mode multifunction inverse filter using CDBAs", *Int. J. of Comp. Science and Information Security*, 11(12), (2013), 50-52.
- N. Herencsar, A. Lahiri, J. Koton and K. Vrba, "Realizations of second-order inverse active filters using minimum passive components and DDCCs", *Int. Conf. Telecom. and Signal Processing (TSP 2010)*, 38–41.
- K. Garg, R. Bhagat and B. Jaint, "A novel multifunction modified CFOA based Inverse filter", *IEEE Int. Conf. Power Electronics (IICPE)*, 1–5, 2012. <https://doi.org/10.1109/IICPE.2012.6450471>
- T. Tsukutani, Y. Sumi and N. Yabuki, "Electronically tunable inverse active filters employing OTAs and grounded capacitors", *Int. Journal of Electronics Letters*, 4(2), (2016), 166–176. <https://doi.org/10.1080/21681724.2014.984636>
- V. Patil, and R. K. Sharma, "Novel inverse active filters employing CFOAs", *Int. J. Scientific Research & Development*, 3(7), (2015), 359-360.
- C. K. Choubey, G. Tiwari and S. K. Paul, "CCII based multifunction inverse filter", *IEEE Int. Conf. on Advances in Electronics, Comm. and Computer Tech. (ICAECTT)*, Dec 2-3, 2016.
- A. K. Singh, A. Gupta and R. Senani, "OTRA-based multifunction inverse filter configuration", *Theoretical and Applied Electrical Engg.*, 15(5), (2018), 846-856. <https://doi.org/10.15598/aece.v15i5.2572>
- A. Pradhan and R. K. Sharma, "Generation of OTRA-based inverse all pass and inverse band reject filters", *Proceedings of Nat. Acad. of Sci. India Section A: Physical Sciences*, 1-11, 2019
- R. Bhagat, D. R. Bhaskar and P.Kumar, "CMOS CDBA-based inverse filter structure" *Int. J. of Innovative Tech. and Exploring Engg.*, 9(3), 2020, 2226-2231.
- J. Srivastava, R. Bhagat and P. Kumar, "Analog inverse filters using OTAs", 6th Int. Conf. on Control, Automation and Robotics (ICCR), 2020, 627-631. <https://doi.org/10.1109/ICCR49639.2020.9108048>

AUTHORS PROFILE



Dr. Anisur Rehman Nasir, is currently working as associate professor in Electronics Engineering, University Polytechnic, Jamia Millia Islamia, New Delhi. He has also worked as lecturer in Royal Commission for Yanbu and Jubail, Saudi Arabia for about three years. He has received his B. Sc. Engg. and M. Sc. Engg. degrees all from Aligarh

Muslim University, Aligarh, India in 1988 and 1991 respectively. He obtained his Ph.D. degree in Electronics and Communication Engineering from Jamia Millia Islamia in the year 2014. He teaches Basic electronics, Electronic circuit design, Computer system architecture and Digital system design. His research interest includes Current-mode analog signal processing and digital circuits. He has published many research papers in international journals and conference proceedings.



Dr. S. N. Ahmad, has retired as professor and Head of Department of Electronics and Communication Engineering, JMI, New Delhi. He received his B. Sc. Engg. Degree in Electrical Engineering and M. Sc. Engg. degree in Control & Instrumentation from, Aligarh Muslim University, Aligarh, India in 1975 and 1979 respectively. He

received his Ph. D. degree from Jamia Millia Islamia, New Delhi in 2005. He is one of the founder faculty of engineering & Technology, JMI, New Delhi He has published and presented more than 30 research papers in the Inter/National Journals/conferences. His research interests are analog signal processing applications and current-mode circuits, low power MOS circuits, image processing.

