

# A Novel Approach of Image Fusion Techniques using Ant Colony Optimization

Jyoti S. Kulkarni, Rajankumar S. Bichkar

**Abstract:** Ant Colony Optimization (ACO) is a relatively high approach for finding a relatively strong solution to the problem of optimization. The ACO based image fusion technique is proposed. The objective function and distance matrix is designed for image fusion. ACO is used to fuse input images at the feature-level by learning the fusion parameters. It is used to select the fusion parameters according to the user-defined cost functions. This algorithm transforms the results into the initial pheromone distribution and seeks the optimal solution by using the features. As to relevant parameters for the ACO, three parameters ( $\alpha$ ,  $\beta$ ,  $\rho$ ) have the greatest impact on convergence. If the values of  $\alpha$ ,  $\beta$  are appropriately increased, convergence can speed up. But if the gap between these two is too large, the precision of convergence will be negatively affected. Since the ACO is a random search algorithm, its computation speed is relatively slow.

**Keywords:** Convergence, Heuristic, Pheromone

## I. INTRODUCTION

Ant colony optimization is a soft computing technique for solving hard discrete optimization problems. It is used for searching for the optimal solutions based on the actions of ants try to find a path between their colony and the source of food. Ants deposit pheromone on the ground that forms a trail. This attracts other ants. There are forward and backward working modes for the ants. The ant's memory retraces the path followed while searching for the destination node.

The algorithm works on initialization, construction- update, and decision steps which are depends on the ant's path selection as well as changes in pheromone values. The possibility of selection of paths depends on the attractive coefficient and the coefficient of pheromones. In the first stage, a random position is assigned to artificial ants. Initializing the pheromone and heuristic matrices calculates the likelihood of path selection. With a certain predefined constant, the pheromone matrix is initialized while the heuristic matrix is initialized by taking an image's mean and variance product. In the second phase, on the each iteration, the path selection probability is calculated using equation 1,

$$P_{ij}^n = \frac{[\tau_{ij}]^\alpha [\eta_{ij}]^\beta}{\sum [\tau_{ij}]^\alpha [\eta_{ij}]^\beta} \quad (1)$$

Where, the pheromone value for pixel (i, j) is given by  $\tau_{ij}$  and the heuristic information at pixel (i, j) is given by  $\eta_{ij}$ .

The influence of the pheromone and heuristic information is controlled by constants  $\alpha$  and  $\beta$ , respectively. Each ant locally updates the pheromone levels at its position after moving to a new pixel by using the equation 2,

$$\tau_{ij} = ((1 - \rho) * \tau_{ij} + (\rho * \tau_{init})) \quad (2)$$

Where pheromone decay coefficient is given by  $\rho$  and the initial pheromone value is given by the  $\tau_{init}$ . When all ants complete the tours and before starting a new iteration, a pheromone update is performed globally by,

$$\tau \leftarrow ((1 - \rho) * \tau + \sum \rho \Delta \tau) \quad (3)$$

In the decision phase, the threshold value of the pixel is decided using the final pheromone matrix. The final pixel values are calculated by using the threshold.

This paper is organized into five sections. An introduction is the first section of the paper. After this, the next section will give a literature review in ant colony optimization. The proposed technique and also the entire process are presented in the next section. Experimental results on four data sets are illustrated in the results and discussions part. Finally, conclusion is presented in the last section.

## II. LITERATURE REVIEW

Saleh *et al.* [1] presented iris and signature multibiometrics system for particular identification using ant colony optimization method. George *et al.* [2] proposed recognition of palmprint using a combination of ant colony optimization, Gabor filter, and SVM. Ant colony optimization is used for edge detection and the Gabor filter is used for feature extraction. The classification of features is done by an SVM classifier. Pandey *et al.* [3] proposed the score level fusion using ant colony optimization in which score level is available from the features of the input image. The decision level and score level is given to ACO to take the final decision for fusion. Ant Colony optimization can also be used for image feature selection [4]. Initially, the Gray level co-occurrence matrix is used to collect the properties. These properties are given to ACO to select the optimum features.

Imani *et al.* [5] proposed a feature selector by hybrid ACO and GA. In the feature selection, GA works for search and ACO for the positive feedback. The use of ACO for image enhancement is explained in [6, 7]. Gao *et al.* [9] proposed a novel technique about band selection using ACO. Two objective functions based on supervised JM distance and unsupervised simplex volumes are introduced. The JM distance measures the distance between the two classes and simplex volume is used for endmember extraction.

Manuscript received on June 16, 2021.

Revised Manuscript received on June 22, 2021.

Manuscript published on June 30, 2021.

\*Correspondence Author

Jyoti S. Kulkarni\*, Assistant Professor, Pimpri Chinchwad College of Engineering, Pune (Maharashtra), India.

Rajankumar S. Bichkar, Principal, Vidya Pratishthan's Kamalnayan Bajaj Institute of Engineering and Technology, Baramati (Maharashtra), India.

© The Authors. Published by Blue Eyes Intelligence Engineering and Sciences Publication (BEIESP). This is an open access article under the CC BY-NC-ND license (<http://creativecommons.org/licenses/by-nc-nd/4.0/>)

To improve the quality of extracted endmember, the spatial-spectral preprocessing is done by fusing the spatial and spectral information. Sandip *et al.* [13] suggested a technique to enhance the performance of the multi-biometric system. This is obtained by using score level fusion using ant colony optimization. The features are extracted from two modalities i. e. face and iris and stored in the database. During identification, ACO is used to select the optimum weight to identify the face.

Luan *et al.* [11] proposed a novel hybrid GA and ACO algorithm. This is used to overcome the supplier selection problem. The GA is used to find the optimum solutions. These solutions are used to initiate the ACO pheromone and hence to find the best solution. Yin *et al.* [12] explained the retrieval of urban road information from a very high-resolution image using a direction-guided ACO method. The edge detection and segmentation are done on the input image. Then the edge detected and segmented images are fused. This fused image is given to ACO to initialize the pheromone. Then the best solution is given by ACO.

Ant Colony Optimization (ACO) is a relatively high approach for finding a relatively strong solution to the problem of optimization. The ant colony optimization technique can be used as the classifier. In Saleh *et al.* [1], contourlet transform is used to extract the features of iris and the features of signatures are extracted using linear discriminant analysis. These two unimodal biometric systems are combined using decision level fusion where the iris sample is classified as either accepted or rejected by ant colony optimization technique. Another way to use the ACO is to select the weights and fusion rule [13]. In this, the input is hand-vein, and the hand-shape images are taken by thermal and digital camera. To fuse these input images, ACO is used to select the proper weight [3].

The ACO technique can also be used for edge detection. In George *et al.* [2], the ACO and Gabor filter is used. The ant colony system is applied for edge detection and then this image is filtered by the Gabor filter to extract the features. The features can also be selected by using ACO also [4, 12]. For image enhancement, ACO is combined with other evolutionary algorithms like GA and Particle Swarm Optimization (PSO) [6, 7, 11]. One novel technique about band selection using ACO is given by Gao *et al.* [9]. Two objective functions based on supervised JM distance and unsupervised simplex volumes are introduced. The JM distance measures the distance between the two classes and simplex volume is used for endmember extraction. To improve the quality of extracted endmember, the spatial-spectral preprocessing is done by fusing the spatial and spectral information.

### III. IMAGE FUSION USING ACO

In the initialization stage, in a random location, artificial ants are allocated. To measure the probability of path selection, the pheromone and heuristic matrices are initialized. With a certain user-specific constant, the pheromone matrix is initialized while the heuristic matrix is initialized by taking an image's mean and variance product. A global pheromone is changed when all ants make their tours and before beginning a new iteration. Using the final pheromone array, pixels are selected in the decision stage. The threshold value is used to find the best value. Fig. 1 shows the block diagram of image fusion using the ACO method. The ACO parameters are set as follows.

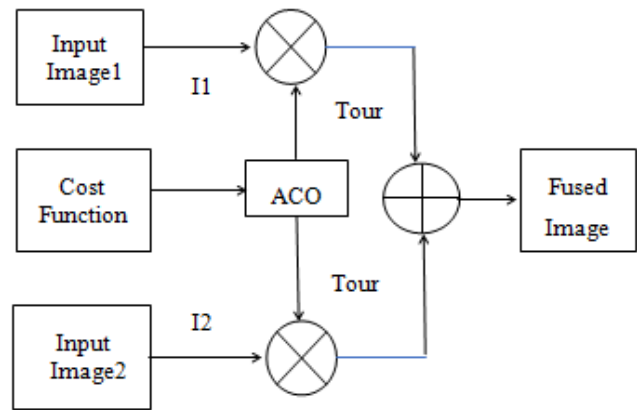

Fig. 1: Block diagram of image fusion using ACO method.

The steps for ACO based image fusion are as follows:

1. Two input images are selected from the mentioned dataset to perform image fusion. Let the size of the image be  $n \times n$ . Set the ACO parameters given in table 1.

Table -1: ACO Parameters

ACO Parameter	Variable	Value
Number of iteration	MaxIt	50
Number of Ants	nAnt	500
Phromone Exponential Weight	$\alpha$	0.1
Heuristic Exponential Weight	$\beta$	10
Pheromone decay coefficient	$\rho$	0.05

2. Distance matrix of size  $n \times n$  is calculated by using equation 4.
 
$$D(i, j) = (x(i, j) - y(i, j))$$

$$D(j, i) = (x(j, i) - y(j, i)) \quad (4)$$
 Where  $i$  and  $j$  represent the row and column number varies in the range of 1 to  $n$ .
3. Initialize the ant tour randomly where the ant moves from its current pixel to the neighboring pixel which is not visited previously.
4. Calculate the initial pheromone from the mean and variance of input images.
5. Calculate the heuristic information by intensity variation matrix from the distance matrix and the probability of path selection using equation 2.
6. From this probability, ant tour is selected by using the roulette wheel selection method. The cost of this tour is calculated using a cost function. The cost function used is the RMSE formula. For multiobjective, RMSE and SF are used in the cost function.
7. The threshold value of the cost function is predefined by considering the best cost. If the cost of the current tour is less than the best cost then the best cost value is replaced by the current tour cost otherwise discarded.

8. The pheromone is updated for all ants by using equation 3. The pheromone is updated either by evaporation by decreasing the value of pheromone or by deposit by increasing the value.
9. Finally, the best cost is saved for the iteration. Steps 4 to 10 are repeated for all iterations.
10. Image fusion is performed on different input image sets. As the single method is implemented in this chapter, the results of the same input types are shown in one figure and table. Image fusion is performed on different input image sets as discussed earlier. Two test sets of each type of input image are used and compared for visual inspection as well as quality metrics.

**IV. RESULT AND DISCUSSIONS**

Fig. 2 shows the results obtained by proposed methods for multisensor input images. The fused images are good and reflect complete fusion visually. Table 2 gives the performance parameters. SF, MI, and AG are superior in MOACO.

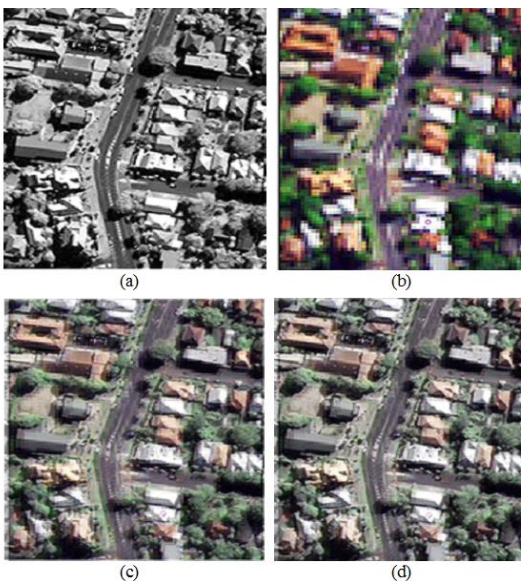
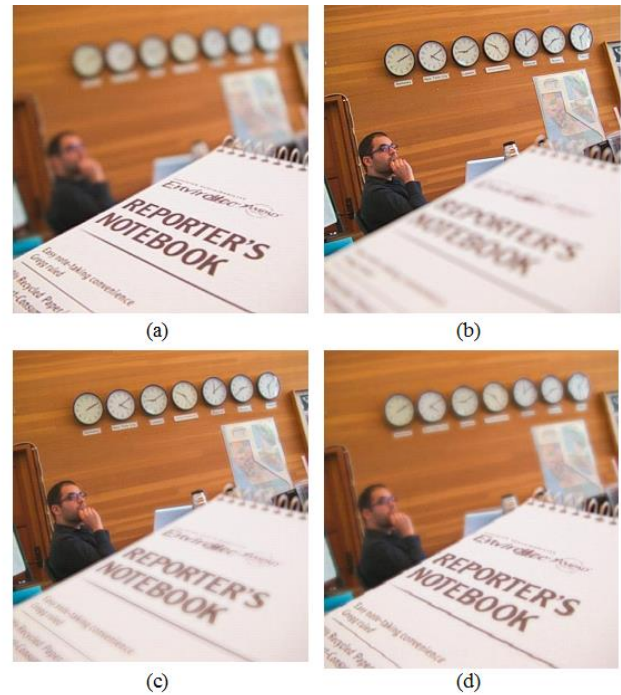

**Fig. 2: Image fusion for multisensor images. (a) and (b) are input images, (c) and (d) are the fused images obtained by single objective ACO and MOACO respectively.**

**Table 2: Performance parameters of the fused image obtained by ACO method for multisensor images.**

Quality Metrics	ACO (Fig.2 (c))	MOACO (Fig. 2 (d))
Mean	134.67	110.19
Entropy	7.22	7.83
Var	1817.52	3502.73
Std Dev	42.63	59.18
RMSE	39.7	40.5
PSNR	35.33	36.88
SF	21.38	32.9
MI	1.32	2.8
IQI	0.14	1
AG	8.75	15.66

Fig. 3 shows the results obtained by proposed methods for multifocus input images. Table 3 gives the performance parameters for the same. In this, MI is better by MOACO than ACO.



**Fig. 3: Image fusion for multifocus images. (a) and (b) are input images, (c) and (d) are the fused images obtained by single objective ACO and MOACO respectively.**

**Table 3: Performance parameters of the fused image obtained by ACO method for multifocus images**

Quality Metrics	ACO (Fig. 3 (c))	MOACO (Fig. 3 (d))
Mean	156.79	156.94
Entropy	7.44	7.40
Var	4561.48	4521.53
Std dev	67.53	67.24
RMSE	9.57	9.87
PSNR	60.35	65.12
SF	19.09	15.20
MI	4.12	6.81
IQI	0.97	0.98
AG	5.64	5.12

Fig. 4 shows the results obtained by proposed methods for multisensor medical input images. Table 4 gives the performance parameters for the same. In the performance parameter, the RMSE and AG are good in ACO whereas SF and MI are good in MOACO.





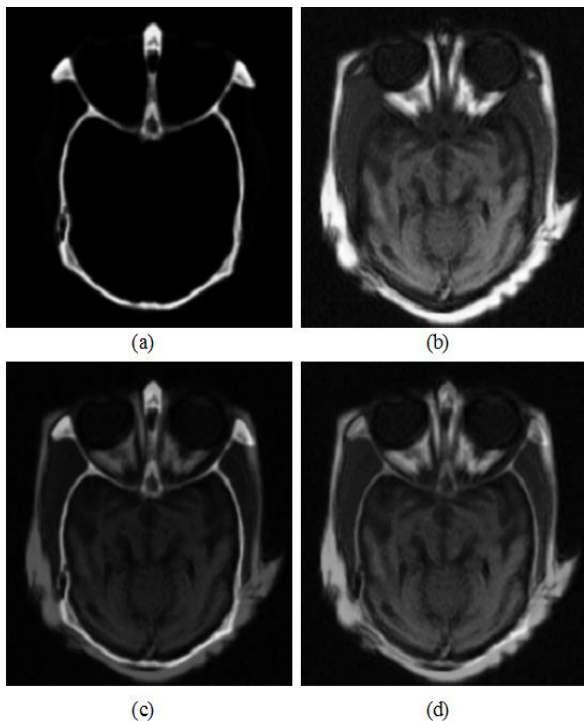

Fig. 4: Image fusion for multisensor medical images. (a) and (b) are input images, (c) and (d) are the fused images obtained by single objective ACO and MOACO respectively.

Table 4: Performance parameters of the fused image obtained by ACO method for multisensor medical images.

Quality Metrics	ACO (Fig. 4 (c))	MOACO (Fig. 4 (d))
Mean	46.43	37.42
Entropy	5.98	5.94
Var	2247.30	1458.56
Std dev	47.40	38.19
RMSE	38.42	39.93
PSNR	35.87	33.16
SF	9.62	11.76
MI	2.78	5.27
IQI	0.59	0.60
AG	4.51	3.85

The performance of the multisensor night vision image is shown in Fig. 5 and quality metrics in table 5. Here also the fused image obtained by MOACO is better than ACO.

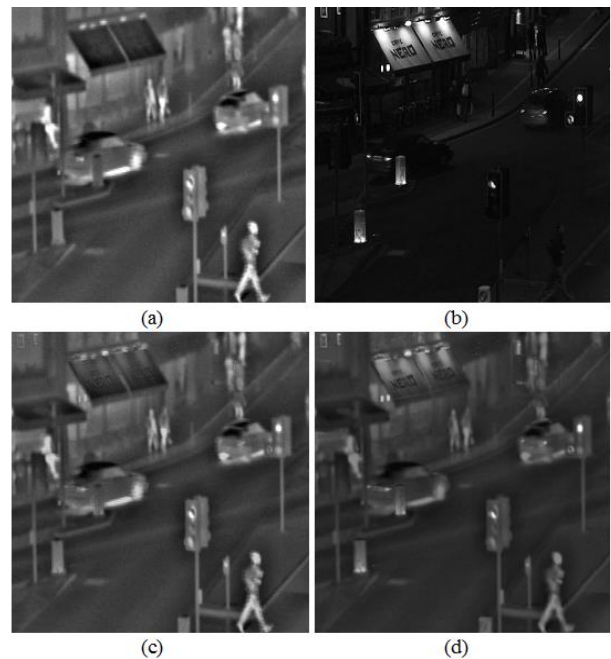

Fig. 5: Image fusion for night vision images. (a) and (b) are input images, (c) and (d) are the fused images obtained by single objective ACO and MOACO respectively.

Table 5: Performance parameters of the fused image obtained by ACO method for night vision images.

Quality Metrics	ACO (Fig. 5 (c))	MOACO (Fig. 5 (d))
Mean	67.19	53.30
Entropy	6.34	5.95
Var	646.34	431.42
Std dev	25.42	20.77
RMSE	36.36	36.40
PSNR	36.58	36.01
SF	9.85	9.12
MI	2.05	2.87
IQI	0.16	0.30
AG	3.90	3.17

Table 6, 7, and 8 show the performance parameters of the fused image obtained by varying the pheromone exponential weight, heuristic exponential weight, and pheromone decay coefficient respectively. From table 6, RMSE and PSNR are good at 0.001, whereas SF, IQI, and AG are good at 0.1 and MI at 0.01. From table 7, by increasing the value of the heuristic exponential weight, RMSE and SF values are decreased. MI is good at 100 whereas IQI and AG are good at 10. From table 8, by increasing the pheromone decay coefficient, the RMSE, PSNR, and IQI are good at 0.05 whereas SF and AG at 0.01. MI is increasing by increasing the value of the pheromone decay coefficient. Thus pheromone exponential weight, heuristic exponential weight, and pheromone decay coefficient are selected as 0.1, 10, and 0.05 for optimum result.



**Table 6: Performance parameters of the fused image obtained by ACO method by varying pheromone exponential weight for multisensor images.**

Quality Metrics	$\beta = 10, \rho = 0.01$		
	$\alpha = 0.1$	$\alpha = 0.01$	$\alpha = 0.001$
Mean	105.66	118.25	138.76
Entropy	7.81	7.24	7.28
Var	3519.10	1673.08	1956.24
Std dev	59.32	40.90	44.23
RMSE	46.36	48.54	44.19
PSNR	34.17	33.25	35.13
SF	27.48	23.70	19.73
MI	1.64	3.44	2.86
IQI	1.00	0.37	0.44
AG	12.23	9.52	7.24

**Table 7: Performance parameters of the fused image obtained by ACO method by varying heuristic exponential weight for multisensor images.**

Quality Metrics	$\alpha = 0.1, \rho = 0.01$		
	$\beta = 10$	$\beta = 100$	$\beta = 1000$
Mean	105.66	149.28	121.27
Entropy	7.81	7.43	7.22
Var	3519.10	2501.73	1649.91
Std dev	59.32	50.02	40.62
RMSE	46.36	44.19	39.70
PSNR	34.17	35.13	37.27
SF	27.48	26.74	18.87
MI	1.64	6.22	2.21
IQI	1.00	0.12	0.34
AG	12.23	10.64	7.68

**Table 8: Performance parameters of the fused image obtained by ACO method by varying pheromone decay coefficient for multisensor images.**

Quality Metrics	$\alpha = 0.1, \beta = 10$		
	$\rho = 0.01$	$\rho = 0.05$	$\rho = 0.1$
Mean	105.66	105.66	113.31
Entropy	7.81	7.81	7.27
Var	3519.10	3519.10	1759.19
Std dev	59.32	59.32	41.94
RMSE	46.36	39.92	54.67
PSNR	34.17	37.16	30.87
SF	27.48	18.73	26.51
MI	1.64	2.32	5.71
IQI	1.00	1.00	0.41
AG	12.23	7.52	10.55

**V. CONCLUSIONS**

ACO is used to fuse input images at the feature level by learning the fusion parameters. ACO is used to select the

fusion parameters according to the user-defined cost functions. This algorithm converts the results to the initial pheromone distribution and uses the features to find the best solution. Three parameters have the greatest effect on convergence when it comes to applicable parameters for the ACO:  $\alpha, \beta, \rho$ . If the values of  $\alpha, \beta$  are appropriately increased, convergence can be accelerated. But if the gap between these two is too large, the performance will be negatively affected. Since the ACO is a random search algorithm, its computation speed is relatively slow.

**REFERENCES**

1. Ibrahim A. Saleh, and laheeb M. Alzoubiady, "Decision level fusion of iris and signature biometrics for personal identification using ant colony optimization", *International Journal of Engineering and Innovative Technology*, vol. 3, issue 11, pp. 35-41, May 2014.
2. Merlin Linda George, Themozhi Govindarajan, and Sudheer Reddy Bandi, "An Intelligence Based Approach for Palmprint Recognition using Ant Colony Optimization", *International Journal of Pure and Applied Mathematics*, vol. 119, no. 12, pp. 14785-14808, 2018.
3. Nirmal Pandey, O. P. Verma, and Amioy Kumar, "A Hand-Based Biometric Verification System Using Ant Colony Optimization", *Journal of Information Sciences and Computing Technologies*, vol. 7, issue 2, pp. 693-717, April 2018.
4. Richa Sharma, and Anuradha Purohit, "Image Feature Selection using Ant Colony Optimization", *International Journal of Innovative Technology and Exploring Engineering*, vol. 9, issue.1, pp. 2669-2674, November 2019.
5. Maryam Bahojb Imani, Tahereh Pourhabibi, Mohammad Reza Keyvanpour, and Reza Azmi, "A new feature selection method based on ant colony and genetic algorithm on Persian font recognition", *International Journal of Machine Learning and Computing*, vol. 2, no. 3, pp. 278-282, June 2012.
6. Biao Pan, "Application of ant colony mixed algorithm in image enhancement", *Computer Modelling & New Technologies*, vol. 18, no. 12B, pp. 529-534, 2014.
7. Kanika Gupta, and Akshu Gupta, "Image Enhancement using Ant Colony Optimization", *IOSR Journal of VLSI and Signal Processing*, vol. 1, issue. 3, pp. 38-45, December 2012.
8. Bing Zhang, Xun Sun, Lianru Gao, and Lina Yang, "Endmember Extraction of Hyperspectral Remote Sensing Images Based on the Ant Colony Optimization (ACO) Algorithm", *IEEE Transactions On Geoscience And Remote Sensing*, vol. 49, no. 7, pp. 2635- 2646, July 2011.
9. Jianwei Gao, Qian Du, Lianru Gao, Xu Sun, Bing Zhang, "Ant colony optimization-based supervised and unsupervised band selections for hyperspectral urban data classification", *Journal of Applied Remote Sensing*, vol. 8, pp. 085094-1-17, 2014.
10. Sandip Kumar Singh Modak, and Vijay Kumar Jha, "Enhancing Performance of Multibiometric System using Ant Colony Optimization based on Score Level Fusion", *International Journal of Computer Applications*, vol. 170, no. 6, pp. 33-38, July 2017.
11. Jing Luan, Zhong Yao, Futao Zhao, and Xin Song, "A novel method to solve supplier selection problem: Hybrid algorithm of genetic algorithm and ant colony optimization", *Mathematics and Computers in Simulation*, vol. 156, pp. 294-309, 2019.
12. Dandong Yin, Shihong Du, Shaowen Wang, and Zhou Guo, "A Direction-Guided Ant Colony Optimization Method for Extraction of Urban Road Information From Very-High-Resolution Images", *IEEE Journal of Selected Topics in Applied Earth Observations and Remote Sensing*, pp. 1-10, August 2015.
13. Uttam Kumar, Anindita Dasgupta, Chiranjit Mukhopadhyay, N. V. Joshi, and T. V. Ramachandra, "Comparison of 10 Multi-Sensor Image Fusion Paradigms for IKONOS Images", *International Journal of Research and Reviews in Computer Science*, vol. 2, no. 1, pp. 40-47, March 2011.
14. H. B. Kekre, Dharendra Mishra, and Rakhee Saboo, "Review on image fusion techniques and performance evaluation parameters", *International Journal of Engineering Science and Technology*, vol. 5, no. 4, April 2013.



15. Pooja Malviya, and Amit Saxena, "Review of Feature Selection and Optimization of Image Fusion using Wavelet Transform and Heuristic Function", *International Journal of Emerging Trends & Technology in Computer Science*, vol. 2, issue 4, pp. 400-404, July-August 2013.
16. Vaibhav R. Pandit, and R. J. Bhiwani, "Image fusion in remote sensing applications: A review", *International Journal of Computer Applications*, vol. 120, no. 10, pp. 22-32, June 2015.
17. Dharendra Mishra, and Bhakti Palkar, "Image Fusion Techniques: A Review", *International Journal of Computer Applications*, vol. 130, no. 9, pp. 7-13, November 2015.
18. Nikita D.Rane, Bhagwat Kakde, and Manish Jain, "Comparative study of Image Fusion Methods: A Review", *International Journal of Engineering and Applied Sciences*, vol. 4, issue. 10, pp. 67-72, October 2017.
19. Asha G, and Annes Philip, "A Review on Pixel Level Satellite Image Fusion", *International Journal of Computer Applications*, pp. 15-19, 2011.

### AUTHORS PROFILE



**Jyoti S. Kulkarni**, is working as Assistant Professor at the Pimpri Chinchwad College of Engineering. She is currently working towards the Ph.D. degree in Electronics and Telecommunication Engineering from Raisoni College of Engineering and Management research center. Her research interests include image fusion and optimization techniques Her teaching interest include data structures and algorithms, object-oriented programming, design and analysis of algorithms.



**Rajankumar S. Bichkar**, is working as Principal, Vidya Pratishthan's Kamalnayan Bajaj Institute of Engineering and Technology. His research interest include genetic algorithm. He had published more than 56 research papers in international journals and conferences.