

Noise Drain in Wireless Body Area Sensor Network

Yogita L. Kumbhare, Pankaj H. Rangaree

ABSTRACT:-Wireless body area sensor networks low-power integrated circuits, and wireless communications have enabled the design of low-cost, miniature, lightweight, and intelligent physiological sensor nodes. These nodes, capable of sensing, processing, and communicating one or more vital signs, can be seamlessly integrated into wireless personal or body networks (WPANs or WBANs) for health monitoring. These networks promise to revolutionize health care by allowing inexpensive, non-invasive, continuous, ambulatory health monitoring with almost realtime updates of medical records via the Internet.

This paper proposes a power and area efficient electrocardiogram (ECG) acquisition and signal processing application sensor node for wireless body area networks (WBAN). This sensor node can accurately record and detect the QRS peaks of ECG waveform with high-frequency noise suppression. analog front end integrated circuit (IC) and digital application. This ECG sensor node is convenient for long-term monitoring of cardiovascular condition of patients, and is very suitable for on-body WBAN applications.

we minimize the other signal such as the ECG signal along with a bunch of noise is in analog form. In we use the High Pass Filter (HPF) to filter the noise from the ECG Signals. The ECG is a voltage difference, recorded between two metal plates or electrodes on the surface of the body

Index Terms:-Wireless body area sensor network, GSM model, ECG Sensor Node.

I. INTRODUCTION

With the advances in embedded microcontrollers, inexpensive miniature sensors, and wireless networking technologies, there has been a growing interest in using wireless sensor networks in medical applications. For example, wireless sensor networks can replace expensive and cumbersome wired devices for pre-hospital and ambulatory emergency care when real-time and continuous monitoring of vital signs is needed. Moreover, body sensor networks can be formed by placing low-power wireless devices on or around the body, enabling long-term monitoring of physiological data. For elderly patients and people with chronic diseases, an in-house wireless sensor network allows convenient collection of medical data while they are staying at home, thus reducing the burden of hospital stay. The collected data can be passed onto the Internet through a PDA, a cell-phone, or a home computer. The caregivers thus have remote access to the patient's health status, facilitating long-term rehabilitation and early detection of certain physical diseases. If there are abnormal changes in the patient status, caregivers can be notified in a timely manner,

and immediate treatment can be provided. Wireless Body Area Sensor Network (WBASN) consists of miniaturized sensor node attached to human body to collect vital physiological and non-physiological information. Wearable systems for continuous health monitoring are a key technology in helping the transition

to more proactive and affordable healthcare. They allow an individual to closely monitor changes in her or his vital signs and provide feedback to help maintain an optimal health status. If integrated into a telemedical system, these systems can even alert medical personnel when life-threatening changes occur. In addition, the wearable systems can be used for health monitoring of patients in ambulatory settings. For example, they can be used as a part of a diagnostic procedure, optimal maintenance of a chronic condition, a supervised recovery from an acute event or surgical procedure, to monitor adherence to treatment guidelines (e.g., regular cardiovascular exercise), or to monitor effects of drug therapy.

One of the most promising approaches in building wearable health monitoring systems utilizes emerging wireless body area sensor networks (WBASNs). WBASN consists of multiple sensor nodes, each capable of sampling, processing, and communicating one or more vital signs (heart rate, blood pressure, oxygen saturation, activity) or environmental parameters (location, temperature, humidity, light). Typically, these sensors are placed strategically on the human body as tiny patches or hidden in user's clothes allowing ubiquitous health monitoring in their native environment for extended periods of time.

A high-pass filter (HPF) is an electronic filter that passes high-frequency signals. The actual amount of attenuation for each frequency varies from filter to filter. Some Electrical Theory as follows:

Measurement: The electrical signals which command cardiac musculature can be detected on the surface of the skin. In theory one could grab the two leads of a standard volt meter, one with each hand, and see the voltage change as their heart beats, but the fluctuations are rapid and by the time these signals reach the skin they are extremely weak (a few millionths of a volt) and difficult to detect with simple devices. Therefore, amplification is needed.

Amplification: A simple way to amplify the electrical difference between two points is to use an operational amplifier. The gain multiplication factor of an op-amp is controlled by varying the resistors attached to it, and with a gain of 1000 will take a 1 millivolt signal and amplify it to 1 volt.

Manuscript received on May 29, 2012.

Yogita L. Kumbhare, G.H.Raisoni college of Engineering, Nagpur.
Pankaj H. Rangaree, G.H.Raisoni college of Engineering, Nagpur

Noise: Unfortunately, the heart is not the only source of voltage on the skin. Radiation from a variety of things (computers, cell phones, lights, and especially the wiring in your walls) is absorbed by skin and is measured with ECG, in many cases masking your ECG in a sea of electrical noise.

II. SYSTEM ARCHITECTURE

The proposed wireless body area sensor network for health monitoring integrated into a broader multitier telemedicine system. Each user wears a number of sensor nodes that are strategically placed on her body. The primary functions of these sensor nodes are to unobtrusively sample vital signs and transfer the relevant data to a personal server through wireless personal network implemented. The personal server, implemented on a personal digital assistant (PDA), cell phone, or home personal computer, sets up and controls the WBAN, provides graphical or audio interface to the user, and transfers the information about health status to the medical server through the Internet or mobile telephone networks (e.g., GPRS, 3G).

In wireless body area sensor network continuous monitoring and analysis of physiological parameters, the recently proposed Wireless Body Area Networks (WBAN) incorporates context aware sensing for increased sensitivity and specificity. A number of tiny wireless sensors, strategically placed on the human body, create a WBAN that can monitor various vital signs, providing real-time feed back to the user and medical personnel.

Fig 1. Gives a generic example of a body area network where several non-invasive sensor are wore on the body to collect the data ,where the data is store ,processed, analysed and taken action if required. The Hardware of sensor node usually consists of microcontroller, few kilobytes of memory, ultra low power RF transceiver, analog signal conditioning circuitry and battery module to power the node. This ECG is connected to the mini-pc or the PDA. When the patient heart bit is above the normal heart beat it send the message to the doctor that the patient heart bit is above the normal. Doctor can reach the patient or reply the patient and check till how much the heart bit increases.

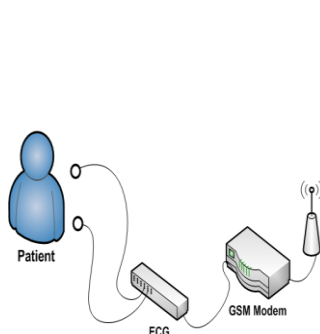

Fig 1: Wireless Body Area Sensor Network

III .HARDWARE IMPLEMENTATION

WBASN like wearability, flexibility, power consumption, and cost have influenced the design for sensor node. The sensor node were design to be wore on the body. The sensor node wore on chest and the arm and different part of the body from were we get the pulse.

A. ECG Design

The nodes can be motion & position sensors such as accelerometers, health monitoring sensors such as ECG, EMG, hearing of visual aid and environment sensors such as oxygen, pressure or humidity sensors. Accelerometers and gyroscopes offer greater sensitivity and are more applicable for monitoring of motion since they generate continuous output. The ECG is nothing but the recording of the heart's electrical activity. The deviations in the normal electrical patterns indicate various cardiac disorders.

The Electrocardiograph (ECG) signal is an electrical signal generated by the heart's beating, which can be used as a diagnostic tool for examining some of the functions of the heart. There are many factors that should be taken into consideration in the design of an ECG amplifier, such as the frequency distortion, interference from electric devices and other sources. The most important kind of noise in an ECG amplifier is the 60 Hz noises, since using a High-pass filter can easily reject both the DC and high frequency noise. A major source of noise when one is recording or monitoring the ECG is the electric power system

As shown in Fig 2. the power goes into the circuit and so do the nodes connected to the body. The signal from the node is amplified by the circuit, it attach to the headphone cable, which is then connected to the PC's . The node comprises of the interface to the PC which is responsible for communicating directly , which will display the ECG information through a graphic user interface (GUI).

The ECG node is responsible for receiving the measured values and combining the information to produce an ECG signal of the patient. Its basic structure includes a PC connected to the radio transceiver. The GSM/GPRS model is used as the interface between the PC and the transceiver.

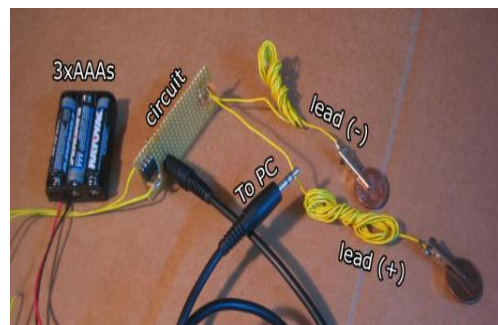

Fig 2: The ECG Design

The Fig 3. is the circuit diagram which is high-gain analog differential amplifier. This circuit uses 6 op-amps to help eliminate effects of noise. It's also safer, because of the diodes interconnecting the electrodes. It just outputs the multiplied difference of the inputs. The 0.1uF capacitor helps stabilize the signal and reduce high frequency noise.

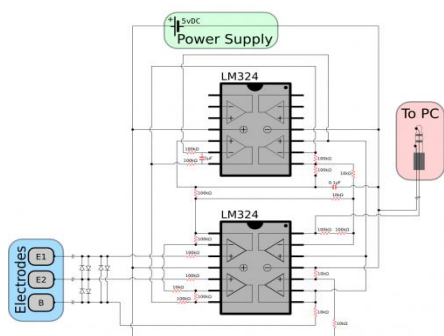

Fig 3: ECG circuit diagram

B. ECG with HPF

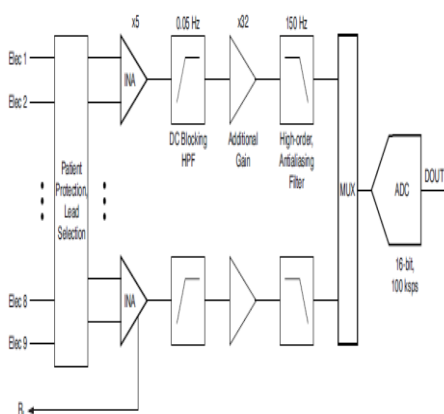

Fig 4: ECG Block Diagram

The design a circuit, which consists a differential amplifier (Instrumentation Amplifier), a Low Pass Filter, a High Pass Filter and a gain stage. The order of these stages is based on the consideration of reducing noises.

The Fig 4. first block is intended for patient protection and defibrillation pulse clamping, which could include high-value resistors or any other kind of isolation circuitry. The lead selection circuitry determines the various electrode combinations to be measured. The ECG electrodes are high-impedance signal sources; therefore, they are fed into the instrumentation amplifiers, which have a very high (greater than 100 dB) and a high input impedance (greater than 10 MΩ). Before the ECG signal is passed to the ADC, it must be amplified so that the entire dynamic range of the ADC..

A typical ADC full-scale voltage is approximately 2.5 V, which implies a gain of 500 (assuming a 5-mV input signal). The total gain is distributed between the instrumentation amplifier (INA) and an additional gain amplifier. Gain is added to the INA in such a way that the electrode dc offset does not saturate the INA. The actual value of this gain depends on the operating voltage of the INA. With the latest trends of analog supply voltage at 5 V, the maximum INA gain can be in the range of 5 to 10. At this point, the dc component must be removed before any further gain can be introduced. Once the dc component is removed, the signal is gained up again with another amplifier. It should be noted that the amplifiers used for these gain stages must be very low noise, so that they do not dominate the noise of the system.

The HPF block is followed by a multiplexer block (mux) that feeds into the ADC. It can be seen in this type of system that there is a significant amount of analog signal processing that occurs before the signal is digitized,

including gain and filtering. Additionally, signal processing in the analog domain limits flexibility.

IV. SYSTEM DESIGN

Our ECG monitoring system can be functionally divided into four subsystems: ECG Sensors, Data Sampling, Wireless Transmission, and Host Interface. ECG signals are first digitized by ADCs to computer via

USB, then through GSM model, transmitted wirelessly to a base station.

The Fig5 shows the input of the signal through ECG node .When the Ecg signal of patient reach beyond the normal bits it send message to the Doctor's .

Without using the High pass filter we get this type of the s as signal through the ECG node as shown in fig 6.

The high-frequency sine waves which are in the original recording due to electromagnetic noise. A major source of noise can be from the alternating current passing through wires travelling through the walls of your house or building.

After high pass filter at 30 Hz. This kills most of your electrical noise (> 30hz), while leaving the ECG intact (< 15Hz). However, it dramatically decreases the volume (potential) of the audio file

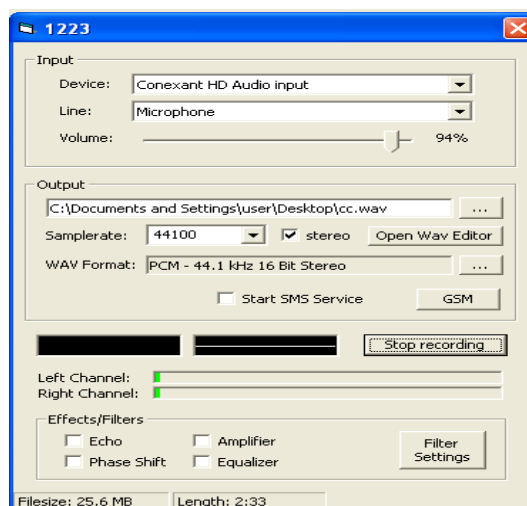

Fig 5: Measuring Signal

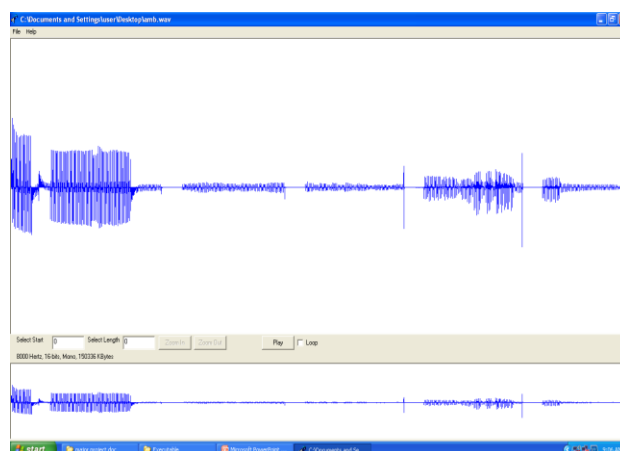

Fig 6: ECG Signal Without HPF



Increase the volume as necessary to maximize the window with the ECG signal as shown in Fig7.

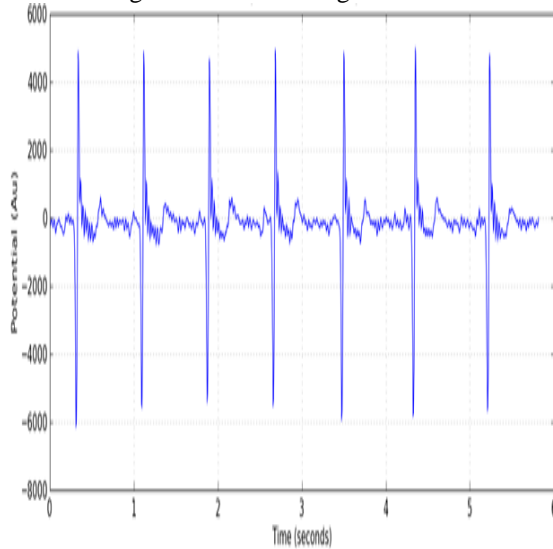

Fig 7: ECG Signal Using HPF

The heart produces changes in electricity that are very slow (the heartbeat is about 1 Hz, or 1 beat per second), so if we can eliminate all of the sine waves with frequencies higher than to clear trace we use the High Pass Filter. A High Noise filter which allow frequencies which are below (low-pass) or above (high-pass) a given frequency . We get the differences of the wave . After using HNF the noise from the original signal is eliminate.

IV. CONCLUSION

This work presents the design and implementation of A Biometric ECG Identification using HPF in Wireless Body Area Sensor Network. Due to the use of HPF we can improve the ECG signal by filtering the extra noise coming from (computers, cell phones, lights, and especially the wiring in your walls). This type of filter should be used WBSN to reduce the noise. It not possible to filter all type of noise, but till some type of noise can be filter to get some accurate data from the ECG signal.

REFERENCES

1. Dipti D. Patil, Shamla Mantri, Himangi Pande, V.M.Wadhai, M.U.Kharat, January 2012 "Feature Extraction Techniques For Mining ECG Signals In WBAN For Healthcare Applications" International Journal of Advances in Computing and Information Researches ISSN:2277-4068, Volume 1- No.1,
2. Honggang Wang, Hua Fang, Liudong Xing, Min Chen,(2011) " An Integrated Biometric-based Security Framework Using Wavelet-Domain HMM in Wireless Body Area Networks (WBAN)" IEEE Communications Society subject matter experts for publication in the IEEE ICC proceedings.
3. Raju Singh(March 2011) "Confidentiality & Authentication Mechanism for Biometric Information Transmitted over Low Bandwidth & Unreliable channel" School of Computer Engineering and IT, Shobhit University, Meerut, India Vol.3, No.2,
4. Mikael Soini, Jussi Nummela, Petri Oksa, Leena Ukkonen and Lauri Sydänheimo (2009)." Wireless Body Area Network for Hip rehabilitation" Tampere University of Technology, Department of Electronics, Rauma Research Unit pp. 202-206 .
5. Cory Cornelius(August 2010) "On Usable Authentication for Wireless Body Area Networks" Department of Computer Science Dartmouth College, Presented at HealthSec, .
6. Jamil Y. Khan, Mehmet R. Yuce, and Farbood Karami "Performance Evaluation of a Wireless Body Area Sensor Network for Remote Patient Monitoring"

7. A. Soomro, D. Cavalcanti, IEEE (Feb 2007)"Opportunities & Challenges using WPAN and WLAN Technologies in Medical Environments", Communications Magazine, vol:45, no:2, page 114-122.
8. Adnan Saeed, Miad Faezipour IEEE 2009, "Plug and Play Sensor Node for Body Area Network",.
9. Jamil Y. Khan,school of computer science,Australia,IEEE (09,07, 2009,) "Wireless Body Area Network for Medical Applications".
10. Emil Jovanov, Dejan Raskovic, John Price,John Chapman, Anthony Moore, Abhishek Krishnamurthy,IEEE (2008) ,," Patient Monitoring Using Personal Area Networks of Wireless Intelligent Sensors".
11. CHRIS OTTO, ALEKSANDAR MILENKOVIĆ, COREY SANDERS, EMIL JOVANOVIĆ, Journal of Mobile Multimedia, Vol. 1, No.4 (2006) 307-326 " SYSTEM ARCHITECTURE OF A WIRELESS BODY AREA SENSOR NETWORK FOR UBIQUITOUS HEALTH MONITORING".
12. Chao Chen and Carlos Pomalaza-Ráez , International Journal of Computer Science and Information Technology, Volume 2, Number 3, 16June 2010., ,"Implimenting and EvaluatingA wireless body Sensor System for Automated Physiological Data Acquisition At Home",
13. Frank Agyei-Ntim, Member IEEE, Kimberly Newman, Senior Member IEEE, September 2-6, 2009, "Lifetime Estimation of Wireless Body Area Sensor Network for Patient Health Monitoring" 31st Annual International Conference of the IEEE EMBS Minneapolis, Minnesota, USA,
14. Adnan Saeed, Mehrdad Nourani, Gil Lee, Gopal Gupta and Lakshman Tamil ,IEEE 2007, " A Scalable Wireless Body Area Sensor Network for Health-Care Monitoring " , The University of Texas at Dallas, Richardson, Texas.
15. Adnan Saeed*, Miad Faezipour*, Mehrdad Nourani*, Subhash Banerjee, June 2009 , " A Scalable Wireless Body Area Network for Bio-Telemetry", Journal of Information Processing Systems, Vol.5, No.2.
16. Aleksandar Milenković, Chris Otto, Emil Jovanov, Accessed: July 2005, "Wireless Sensor Networks for Personal Health Monitoring:Issues and an Implementation" .
17. Mehmet R. Yuce & Steven W. P. Ng & Naung L. Myo &Jamil Y. Khan &Wentai Liu , "Wireless Body Sensor Network Using Medical Implant Band", Received: 10 July 2007 / Accepted: 25 July 2007
18. CHRIS OTTO, ALEKSANDAR MILENKOVIĆ, COREY SANDERS, EMIL JOVANOVIĆ, January 10, 2006 "SYSTEM ARCHITECTURE OF A WIRELESS BODY AREA SENSOR NETWORK FOR UBIQUITOUS HEALTH MONITORING"
19. Xiyao Zhang, September 28, 2003" A Design of ECG Amplifier", Report of Project #1
20. Mehmet R. Yuce & Steven W. P. Ng & Naung L. Myo & Jamil Y. Khan &Wentai Liu, Accepted: 25 July 2007 " Wireless Body Sensor Network Using Medical Implant Band"

AUTHORS PROFILE



Yogita I.Kumbhare ,Student Of Master In Engineering (Wireless Communication And Computing).In G.H.Raisoni College Of Engineering, Nagpur. Paper Published In International Journal Of Computer Applications® (Ijca)," Wireless Body Area Sensor Network Authentication Using Hmac Function.



assist. Prof .Pankaj H.Rangaree ,Department Of Electronics In G.H.Raisoni College Of Engineering, Nagpur. M TECH (VLSI),Ph.D. Pursuing (Design Approach To Enhance The Lifetime Of Wireless Sensor Network), Paper Presentation On "Electronic And Photonic Integrated Circuit", Around Twelve Papers Selected In Various International Journals & Conferences, (M.Tech): Implementation Of Asynchronous Circuit In Fpga,

