

A Novel Digitally Controlled Converter for Renewable Energy Resources

J.Baskaran, P.Pugazhendiran, M.Sujith

Abstract— A digital PWM controller for Buck-boost converter is designed using MATLAB-Simulink. The mathematical model of PWM controller is derived to design in MATLAB simulation model. In this Proposed model, the digital PWM controller is used to obtain the positive output voltage from the buck boost converter in the range of 101V from the variable input voltage of 50-200V. The proposed model is highly efficient and flexible for all kind of renewable energy conversion methods. In this paper, the basic principles of the proposed digitally controlled Positive buck boost converters are illustrated in detail and also we discussed about the proposed model output voltage is employed for DC Motor applications.

Index Terms —Pulse Width Modulation (PWM) Positive Buck-Boost Converter (PBB), DC motor.

I. INTRODUCTION

In many applications with BB converters required for charging the battery has significantly large variations in output voltage, and hence, the additional switching power supply [1], [2] is indispensable for processing the varied input voltage to create the stabilized output voltage. There are several types of non-isolated converters [1]–[9], such as the Cuk converter, SEPIC converter, etc. As for Cuk, SEPIC, and Zeta converters, each not only possesses the disadvantages of the right-half-plane zero but also needs two inductors, In [3]–[8], the Luo converter and its derivatives, also possessing the disadvantages of the right-half-plane zero, are presented to realize output voltage, but need two or more inductors and hence, also have difficulty in control due to the corresponding high-order transfer functions. This capacity is utilized for improving the dynamic response of PBB to disturbances due to an increase in load or decrease in input voltage [10]. There are some DC-DC applications like hybrid vehicles [12-13] and hybrid power sources [11] which require bidirectional power flow. When there is a requirement for step up and step down voltage conversions using PWM controller (Fig. 1) may be promising. This converter is based on PBB converter

II. PROPOSED SYSTEM MODEL

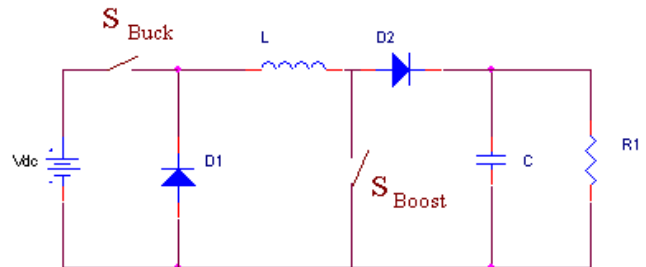

Fig.1: Buck Boost Converter

So we had employed the digital PWM controller which responds to change in the input voltage maintained the output voltage range.

In addition it has advantage of a capacity for extra current storage in the inductor. Comparing the inductor Current in Buck, Boost, inverting Buck Boost and positive Buck Boost, we have:

$$I_1 = \frac{I_0}{D'} = \frac{V_0}{RD'} = \frac{V_1}{RD^2} \quad \text{Boost converter} \quad (1)$$

$$I_1 = \frac{I_0}{D'} = \frac{V_0}{RD'} = \frac{DV_1}{RD^2} \quad \text{PBB converter} \quad (2)$$

$$I_1 = I_0 = \frac{V_0}{R} = \frac{DV_1}{R} \quad \text{Buck Converter} \quad (3)$$

The equation for PBB converter is to

$$I_1 = \frac{1}{D'_{boost}} I_0 = \frac{1}{D'_{boost}} \frac{V_0}{R} = \frac{D_{buck}}{D'^2_{boost}} \frac{V_i}{R} \quad (4)$$

The output equation is

$$V_0 = \frac{D_{buck}}{D_{boost}} V_i \quad (5)$$

III. DIGITAL PWM CONTROLLER FOR PBB CONVERTER

We had developed the digitally controlled pulse width modulation schemes using MATLAB/ Simulink for PBB converter to obtain the high efficiency conversion and flexible of the system. Fig.1 shows that sense circuit for PWM controller, Fig.2: shows the design of open and closed loop PBB converter, Fig.3 shows the Digital PWM control for Buck Mode Operation, Fig.4 shows



the Digital PWM control for Boost Mode Operation

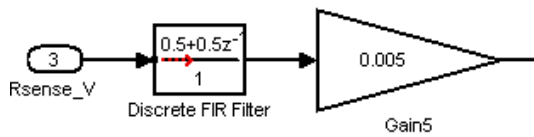

Fig.1 R_{sense} loop for Digital PWM Signal

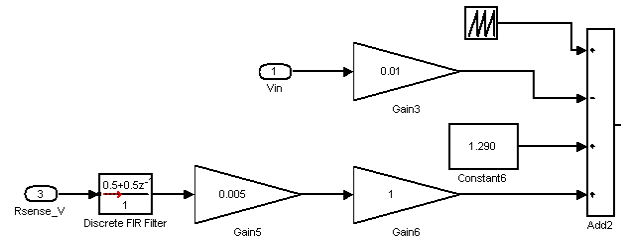

Fig.4: Digital PWM control for Boost Mode Operation

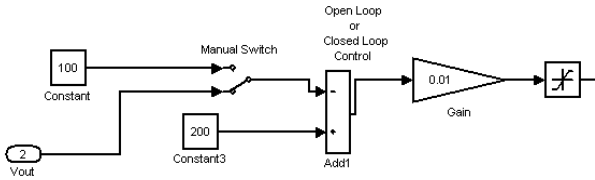

Fig.2 PBB converter designed to operate at both open and closed loop

IV. SIMULATION RESULTS AND DISCUSSIONS

The employed PWM control schemes are used to obtain the positive output voltage. The designed simulation circuit for digitally controlled PBB converter is used for DC motor applications shown in below Fig.5 and simulation values used in this circuit to perform operations of digitally controlled PBB converter is shown in table.

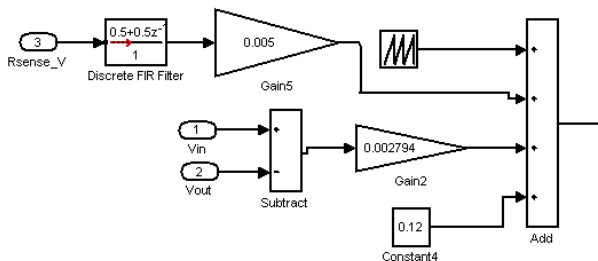

Fig.3 Digital PWM control for Buck Mode Operation

L	10e-03
R1	10 ohm
Rs	0.01 ohm
C1	100e-6
MOSFET Switches (Resistance values)	0.001ohm
Smoothing Inductance	2H

Table.1: Simulation Parameters

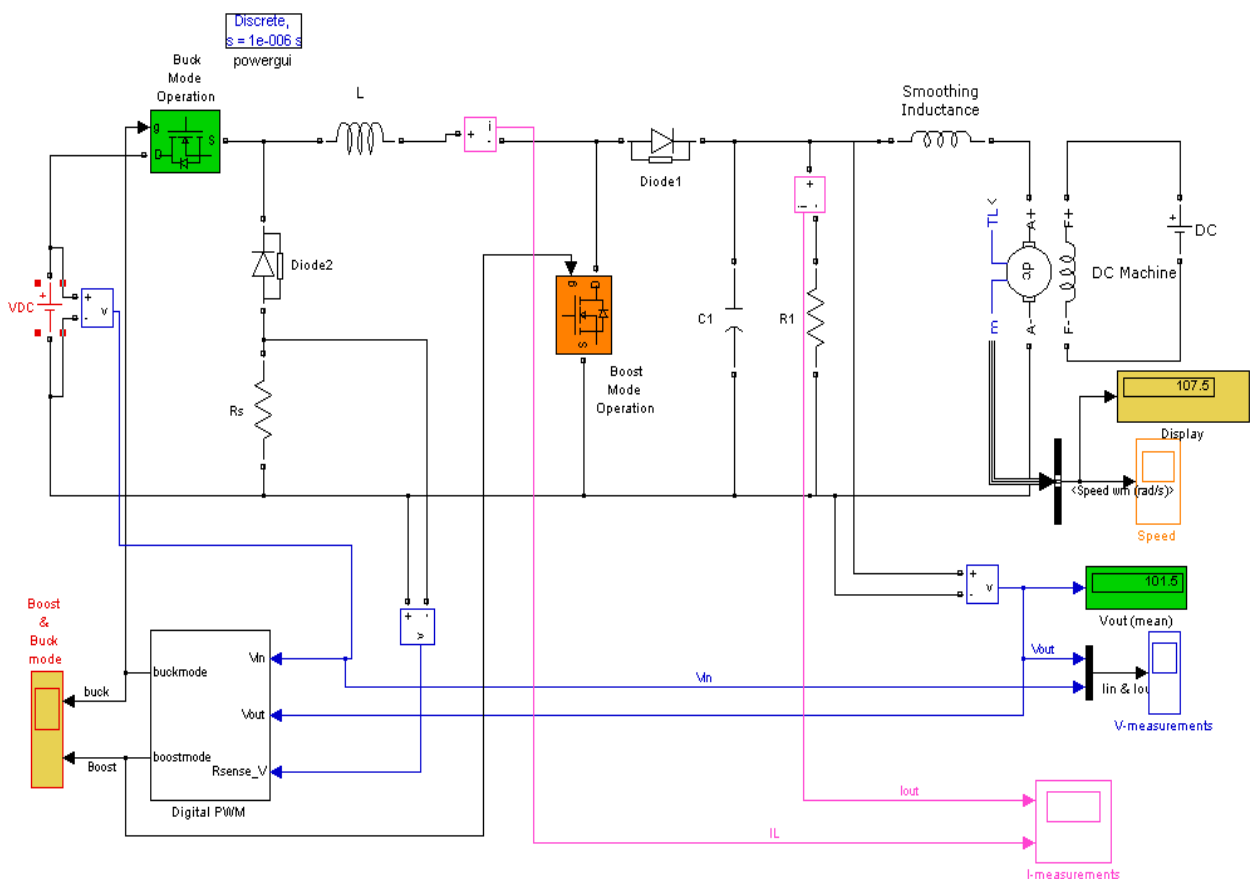

Fig.5 Digital PWM control PBB converter

The simulation results are shown below for input DC voltage for 50V (Fig.6) and 200V (Fig.7). The results show the efficiency of the PBB converter while operating in buck and boost mode.

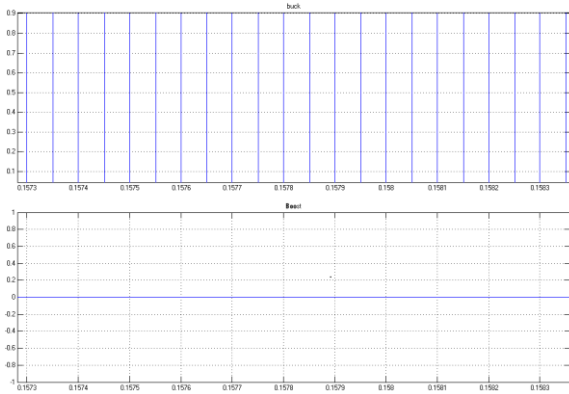

Fig.6 (a) Waveforms for Buck Mode Signals (Input $V_{dc}=200V$)

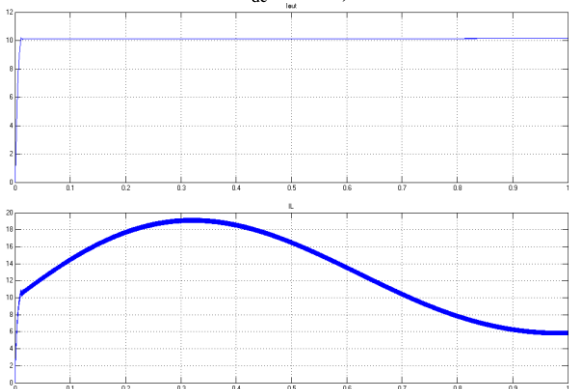

Fig.6(b) Waveforms for I_{out} and I_L (Input $V_{dc}=200V$)

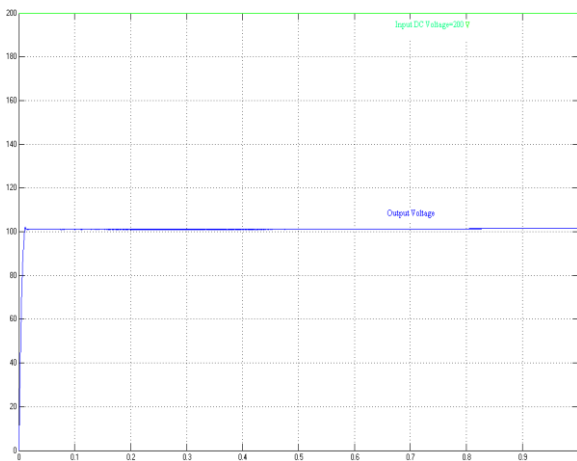

Fig.6(c) Purposed PBB converter output voltage Waveforms (Input $V_{dc}=200V$)

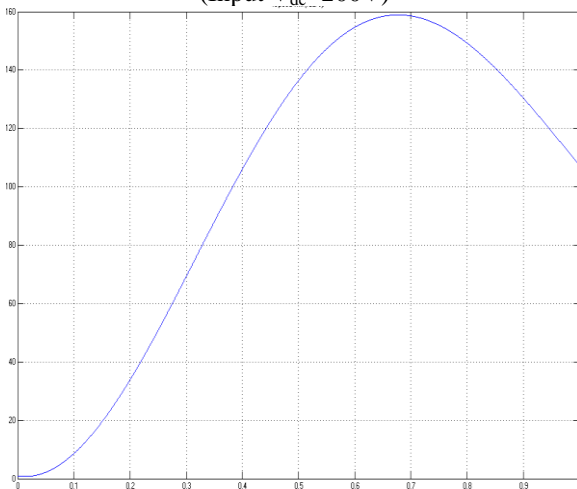

Fig.6(d) Waveforms of PBB converter output for DC motor Applications (Input $V_{dc}=200V$)

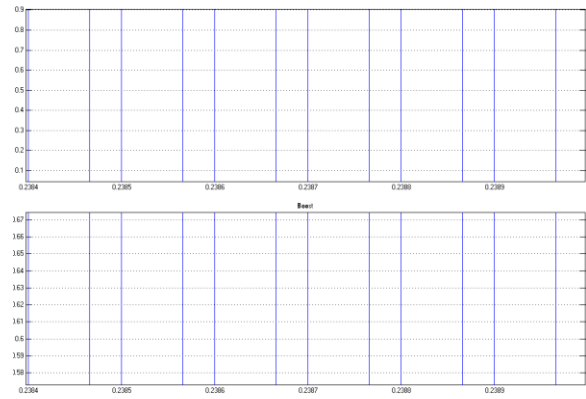

Fig.7 (a) Waveforms for Buck and Boost Mode Signals (Input $V_{dc}=50V$)

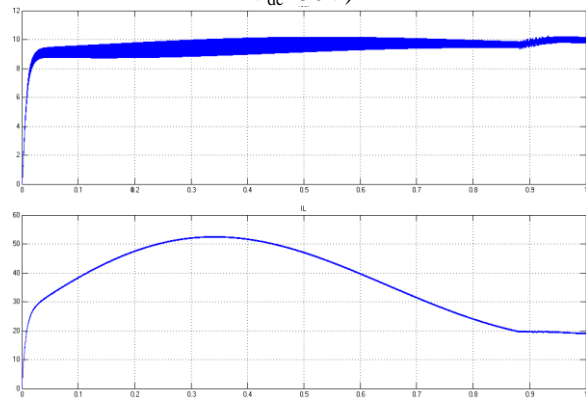

Fig.7(b): Waveforms for I_{out} and I_L (Input $V_{dc}=50V$)

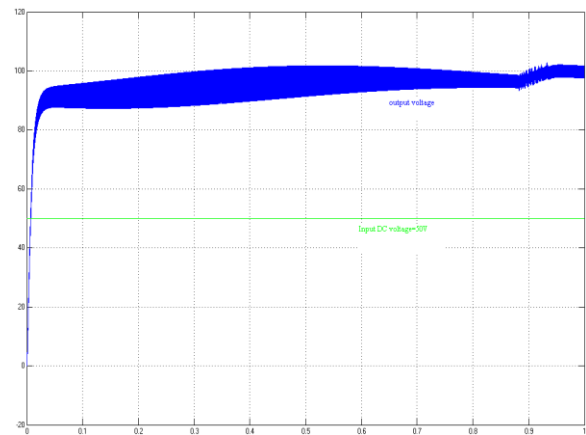

Fig.7(c) Purposed PBB converter output voltage Waveforms (Input $V_{dc}=50V$)

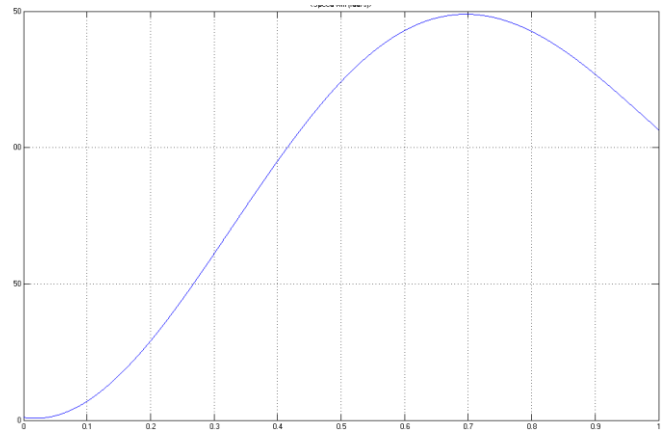

Fig.7 (d) Waveforms of PBB converter output for DC motor Applications (Input $V_{dc}=50V$)

V. CONCLUSION

The proposed Digital control for PBB converter has a positive output voltage. Furthermore, this converter always operates in CCM inherently, thereby causing variations in duty cycle all over the load range not to be so much, and hence, the control of the converter to be easy. A high-efficiency positive buck–boost converter with PWM circuit is proposed in this paper. When the positive buck–boost converter operates in buck– boost mode, the switching loss is comparatively low compared to the other methods. The proposed positive buck–boost converter can precisely provide an adjustable input with a voltage range from 50 to 200 V with constant voltage of 101V and constant output current of 10A. By using Digital PWM techniques, the proposed converter can achieve faster transient response when the supply voltage changes.

ACKNOWLEDGMENT

The authors are would like to thank to the Principal, Prof.Dr.S.S.Jayachandran, IFET College of Engineering, Management Trustees of IFET College of Engineering and the Principal, Management trustees of Adhiparasakthi College of Engineering for providing necessary facilities for the preparation of paper.

REFERENCES

- [1]. R. W. Erickson and D. Maksimovic, *Fundamentals of Power Electronics*, 2nd ed. Norwell, MA: Kluwer, 2001.
- [2]. N. Mohan, T. M. Undeland, and W. P. Robbins, *Power Electronics*, 2nd ed. New York: Wiley, 2003.
- [3]. F. L. Luo, "Positive output Luo converters: Voltage lift technique," *Proc. Inst. Elect. Eng.—Elect. Power Appl.*, vol. 4, no. 146, pp. 415–432, Jul. 1999.
- [4]. X. Chen, F. L. Luo, and H. Ye, "Modified positive output Luo converter," in *Proc. PEDS Conf.*, 1999, pp. 450–455.
- [5]. F. L. Luo and H. Ye, "Positive output super-lift converters," *IEEE Trans. Power Electron.*, vol. 18, no. 1, pp. 105–113, Jan. 2003.
- [6]. F. L. Luo and H. Ye, "Positive output multiple-lift push–pull switched capacitor Luo-converters," *IEEE Trans. Ind. Electron.*, vol. 51, no. 3, pp. 594–602, Jun. 2004.
- [7]. M. Zhu and F. L. Luo, "Development of voltage lift technique on double output transformerless DC–DC converter," in *Proc. IEEE IECON*, 2007, pp. 1983–1988.
- [8]. M. Zhu and L. Luo, "Implementing of developed voltage lift technique on SEPIC, Cuk and double-output DC–DC converters," in *Proc. IEEE ICIEA Conf.*, 2007, pp. 674–681.
- [9]. K. Viswanathan, D. Srinivasan, and R. Oruganti, "A universal fuzzy controller for a non-linear power electronic converter," in *Proc. FUZZ-IEEE Conf.*, 2002, pp. 46–51.
- [10]. "A General Approach to Control a Positive Buck-Boost Converter to Achieve Robustness against Input Voltage Fluctuations and Load Changes" Arash A Boora, Student member, IEEE, Firuz Zare, Senior member, IEEE, Gerard Ledwich, Senior member, IEEE, Arindam Ghosh, Fellow, IEEE In PESC 08 : 39th IEEE Annual Power Electronics Specialists Conference
- [11]. A.B Arsoy, Y. Liu, P.F. Ribeiro and F. Wang "Static-Synchronous Compensators and Superconducting Magnetis Energy Storage Systems in Controlling Power System Dynamics"
- [12]. Hyunjae Yoo, Seung-Ki Sul, Yongho Park, and Jongchan Jeong "System Integration and Power Flow Management for Series Hybrid Electric Vehicle using Super-Capacitors and Batteries" IEEE 2007-10-26
- [13]. J.M. Timmermans, P. Zadora Y. Cheng, J. Van Mierlo, and Ph. Lataire "Modelling and Design of Super Capacitors as Peak Power Unit for Hybrid Electric Vehicles" IEEE 2005
- [14]. P. C. Huang, W. Q. Wu, H. H. Ho, and K. H. Chen, "Hybrid buck–boost feedforward and reduced average inductor current techniques in fast linetransient and high-efficiency buck–boost converter," *IEEE Trans. PowerElectron.*, vol. 25, no. 3, pp. 719–730, Mar. 2010.

- [15]. K. K. I. Hwu and T. T. J. Peng, "A novel buck–boost converter combining KY and buck converters," *IEEE Trans. Power Electron.*, vol. 27, no. 5, pp. 2236–2241, May 2012



Prof. Dr. J. Baskaran was born in Tamilnadu. He received the Ph.D. degree from the Department of Electrical Engineering, he was an Professor /Head in the Department of Electrical and Electronics Engineering, Adhiparasakthi college of Engineering. His current research interests include power system engineering and power electronics. He published more than 20 National and International journals. He is the reviewer of M.Tech thesis evaluation member and also chairperson for national conference observer.



P. Pugazhendiran was born in Tamilnadu, in 1979. Received his UG degree in Electrical and Electronics Engineering from Coimbatore Institute of Technology (CIT) in 2001 and PG degree from College of Engineering Guindy (CEG), Anna university, Chennai in 2009. His research interests includes Power quality issues, Power Converters, Renewable energy sources, Electrical Drives. He Published More than 5 Engineering Books. Teaching Experience over a decade. He is currently working at I.F.E.T College of Engineering as Associate Professor and head of the department. He is a life member of ISTE.



M. Sujith was born in Namakkal, Tamilnadu in 1987. He received the B.E. degree in Electrical and Electronics Engineering from K.S.R. College of Engineering in 2008, and the M.E. degree in Applied Elexctronics from the Annai Mathammal Sheela Engineering College in 2012. He published 2 international journals and Presented papers in 5 national and international conferences. He is currently working at I.F.E.T College of Engineering as Senior Assistant Professor. His main research interests include power electronic converters, compensators and digital communications.