

Operation and Control of Micro Sources in Island Mode of a Microgrid

Murari Lal Azad, Aizad Khursheed, Shubhranshu Vikram Singh

Abstract- In the country like India where population is increasing at a rapid rate the electrical power demand has become a great problem. Unfortunately the conventional energy resources are limited, cause greenhouse emissions and are expected to increase in costs due to an increase in the demand. Recently, the new concept of MicroGrid has been emerging on distribution network for integration of micro generation in low voltage network and to increase the reliability of supply. A microgrid is a cluster of micro generators, loads, storage devices, control devices and a low voltage distribution network functioning in a coordinated manner. The microgrid can operate in two different modes: interconnected or emergency. In first mode the microgrid is connected with the conventional low voltage distribution network for importing or exporting electricity. In emergency mode the microgrid is isolated (islanded) with the help of control devices from the distribution network and uses local micro-generators, changing from power control to frequency control. Most of the micro sources installed in a microgrid cannot be connected directly to the electrical network therefore; power electronics interfaces (dc/ac or ac/dc/ac) are required. Thus, the inverter control is also a challenge for smooth and reliable operation of a smart microgrid. This paper describes microgrid operation in various modes and various control strategies adopted.

Keywords –Frequency control, Islanded Operation, Micro Grid, reliability, Voltage Control.

I. INTRODUCTION

Micro-scale distributed generators (DGs), or micro sources, are being considered increasingly to provide electricity for the expanding energy demands in the network. The development of DGs operated in a MicroGrid also helps to reduce greenhouse gas emissions and increase energy efficiency. Distributed generation encompasses a wide range of prime-mover technologies, such as internal combustion engines, gas turbines, micro turbines, photovoltaic, fuel cells, and wind power. Most emerging technologies such as microturbines, photovoltaic, fuel cells, and gas internal combustion engines with permanent magnet generators have an inverter to interface with the electrical distribution system. In the last decades, the interest on distributed generation has been increasing, essentially due to technical developments on generation systems that meet environmental and energy policy concerns.

Manuscript published on 30 August 2014.

*Correspondence Author(s)

Prof. Murari Lal Azad, has done graduation and post graduation and Doctorate in Engineering from reputed Universities of India.

Mr. Aizad Khursheed, has done his graduation and post graduation in Engineering from Jamia Millia Islamia, New Delhi, India.

Mr. S. Vikram Singh, has done his graduation and post graduation in Engineering from reputed Universities of India.

© The Authors. Published by Blue Eyes Intelligence Engineering and Sciences Publication (BEIESP). This is an [open access](https://creativecommons.org/licenses/by-nc-nd/4.0/) article under the CC-BY-NC-ND license <http://creativecommons.org/licenses/by-nc-nd/4.0/>

The interconnection of distributed generation has been predominately confined to MV and HV levels, but the development of micro generation technology, the decline of its costs and the public incentives to distributed generation lead to an increased installation of micro generation in LV networks. Although there is in general a lack of regulations to frame the operation of micro generators [1], in some countries, Portugal, there is already specific legislation about micro generation. This legislation is intended to encourage the investment on micro generation, namely by subsidizing the remuneration of the electricity produced by these generators and partially funding the investment. The simple integration of micro generation in LV networks, similar to the one that is being used to integrate distributed generation on MV networks [1], may result in technical problems on LV and MV networks (excessive voltages, increase in fault levels, voltage unbalance, overloading, etc.), namely when the penetration of micro generation becomes high [2][3]. The new concept of microgrid emerged as a way to ease this integration, but in fact corresponds to an entirely new way of understanding LV networks, with potential benefits far beyond the easy integration of micro generation [5]-[8].

II. MICROGRID OPERATION

A Microgrid consists of a Low Voltage distribution network with distributed energy sources, such as micro-turbines, fuel cells, PVs, etc., storage devices, i.e. flywheels, energy capacitors and batteries, and controllable loads having control capabilities over the network operation. These systems are interconnected to the Medium Voltage Distribution network, but they can also be operated isolated from the main grid, in case of faults in the upstream network. From the customer point of view, Microgrids provide both thermal and electricity needs, and in addition enhance local reliability, reduce emissions, improve power quality by supporting voltage and reducing voltage dips, and potentially lower costs of energy supply. The basic microgrid architecture is shown in Fig. 1. This consists of a group of radial feeders, which could be part of a distribution system or a building's electrical system. There is a single point of connection to the utility called the point of common coupling. Feeders A,B and C have sensitive loads, which require local generation. The noncritical load feeder D does not have any local generation. Feeders A,B and C can island from the grid using the static switch that can separate in less than a cycle . In this example, there are four microsources at nodes 8, 11, 16, and 22, which control the operation using only local voltages and currents measurements.

When there is a problem with the utility supply, the static switch will open, isolating the sensitive loads from the power grid. Non sensitive loads (Feeder D) rides through the event. It is assumed that there is sufficient generation on Feeders A–C to meet the loads on these feeders. When the microgrid is grid connected, power from the local generation can be directed to the non sensitive load. Most MicroSource technologies that can be installed in an MG are not suitable for direct connection to the electrical network due to the characteristic of the energy produced. Therefore, power electronics interfaces (dc/ac or ac/dc/ac) are required. Thus, inverter control is the main concern specially in islanded mode of MicroGrid operation. The MG is intended to operate in two different operating conditions:

Normal Interconnected Mode: The MicroGrid is connected to a utility grid. Frequency and voltage references are provided by the utility grid. All the inverters connected act like current sources (slaves) following the reference from the conventional grid.

Emergency / Islanding Mode: In this mode the MicroGrid is not connected to a utility grid. Frequency and voltage references are provided by one inverter which acts like a voltage source Inverter (master) and the other inverters connected act like current sources (slaves), following the reference from the VSI. The control of an expandable distributed system without using communication can only be achieved at the price of permitting a small error. Therefore, these control techniques are generally denoted as droop control methods. The dynamics of the MicroGrid during island operation may comprise of photovoltaic panels (PV), a wind turbine, a battery bank for voltage regulation, and a small Diesel Generator. The converters used to couple the PV and the battery storage to the low voltage grid allow MicroGrid operation either in a grid interconnected mode or under islanded conditions

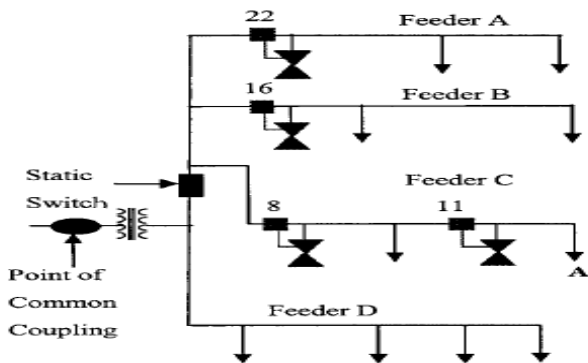

Figure 1 Basic microgrid Architecture Diagram

Microsource Power-Control Configuration: In this configuration each DG regulates the voltage magnitude at the connection point and the power that the source is injecting, P . This is the power that flows from the microsource as shown in Fig. 1. With this configuration, if a load increases anywhere in the microgrid, the extra power comes from the grid, since every DG regulates to constant output power. This configuration fits CHP applications because the production of power depends on the heat demand. Electricity production makes sense only at high efficiencies, which can only be obtained only when the waste heat is utilized. When the system islands, the local power-versus frequency droop function insures that the power is balanced within the island.

Feeder Power Flow-Control Configuration: In this, each DG regulates the voltage magnitude at the connection point and the power that is flowing in the feeder at the Points 8, 11, 16, and 22 in Fig. 1. With this configuration, extra load demands are picked up by the DG, showing a constant load to the utility grid. And hence the microgrid becomes a true dispatchable load as seen from the utility side, allowing for demand-side management arrangements. Again, when the system islands, the local feeder flow-versus-frequency droop function ensures that the power is balanced.

Hybrid Control Configuration: This configuration is the hybrid of previous two in which some of the DGs regulate their output power, P , while others may regulate the power flow to feeder. The same DG can also control either output power or flow of power to feeder that depends upon the need. This mixed control configuration can potentially offer the best of both worlds that Some DG units operating at peak efficiency, recuperating waste heat; and other DGs may ensure that the power flow from the grid stays constant under changing-load conditions within the microgrid.

Microsource Control: In this control the new microsources can be connected to the system without any modification in existing micro sources their set points can be independently chosen. The microgrid can connect to or isolate itself from the grid in a rapid and seamless manner, also its reactive and active power can be controlled independently to meet the dynamic needs of the loads. Each microsource controller must respond autonomously and effectively to system changes without requiring information from the loads, the static switch, or other sources. The basic controller with a feedback control on power and voltage can use real time values of P , Q , frequency, and the ac voltage to generate the desired voltage magnitude and angle at the inverter terminals by using droop concepts.

Voltage–Versus–Reactive-Power (Q) Droop: Integration of large numbers of microsources into a microgrid is not possible with basic unity power-factor controls. Voltage regulation is necessary for local reliability and stability. Without local voltage control, systems with high penetrations of microsources could experience voltage and/or reactive-power oscillations.

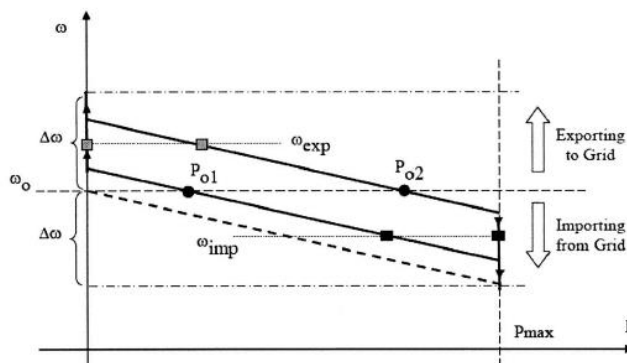

Figure 2 Power Vs Frequency Droop

Reactive power droop controller so that, as the reactive power generated by the microsource becomes more capacitive, the local voltage set point is reduced. Voltage control must also ensure that there are no large circulating reactive currents between sources. With small errors in voltage set points, the circulating current can exceed the ratings of the microsourses. Conversely, as Q becomes more inductive, the voltage set point is increased. When the microgrid is connected to the grid, loads receive power both from the grid and from local microsourses, depending on the customer's situation. If the grid power is lost because of voltage sags, faults, blackouts, etc., the microgrid can autonomously switch to island operation. When regulating the output power, each source has a constant negative-slope droop on the P, ω plane where P is output power and ω is frequency in radians per second. Fig. 2 shows that the slope is chosen by allowing the frequency to drop by a given amount $\Delta\omega$, as the power spans from 0 to P_{max} shown by dashed line. Fig. 2 also shows that P_{o1} and P_{o2} are the power set points for two units. These P_{o1} and P_{o2} are the amount of powers injected by each source to the utility grid at system frequency ω_0 . If the system is switched to island mode then the micr-generators need to increase the power generation to balance it in the island. The new operating point then will be at a frequency that is lower than the nominal value. In this case, both sources have increased their power output, with Unit 2 reaching its maximum power point. If the system is switched to island mode when exporting power to the grid, then the new frequency will be higher, corresponding to a lower power output from the sources, with Unit 1 at its zero-power point. The characteristics shown in Fig. 2 are steady-state characteristics having a fixed slope in the region where the unit is operating within its power range. The slope becomes vertical as soon as any limit is reached. The droop is the locus where the steady-state points are constrained to come to rest, but during dynamics the trajectory will deviate from the characteristic.

III. CONCLUSION

This paper has presented the operation and control methods of a MicroGrid made up of a variety of Micro Sources such as photovoltaic arrays and wind turbines during Island Operation. Inverters can act like current sources (slaves) or like voltage sources (Master), which depends on grid operation. In normal interconnected mode, frequency and voltage reference are defined by the conventional grid and all the inverters present act like current sources (slaves), following the previous reference. In island mode, frequency and voltage are defined by one inverter which acts like a voltage source and the other inverters present in the microgrid act like current sources. As this paper only describes the operation and control methods of a MicroGrid in islanded operation, a battery inverter is considered as a voltage source. An inverter which acts like a current source has a local secondary control by using a PI controller at each controllable MicroSource, which computes the set points of real power so that the frequency will return to the nominal value. This concept allows the parallel operation of the voltage source, which is the main concern in the expansion of renewable supply systems without communication.

Future work will be to consider the dynamic of the storage device, the dynamic of a MicroGrid in normal interconnected mode with a small utility grid and the transition between normal and island mode.

REFERENCES

1. Lopes J.A.P, "Management of MicroGrids", International Electrical Equipment Conference, Bilbao, October, 2003.
2. Lasseter, R. H., Akhil, A., Marnay, C., Stephens, J., Dagle, J., Guttromson, R., Meliopoulos, A., Yinger, R., and Eto, J. (2002). "The CERTS microgrid concept." *White Paper for Transmission Reliability Program*, Office of Power Technologies, U.S. Dept. of Energy, Washington, D.C. Lopes, J., Peças, A., Tomé Saraiva, J., Hatziaargyriou, N., and Jenkins, N. (2003). "Management of microgrids." *Proc., IJEE Conf. 2003*.
3. D.C. Lopes, J., Peças, A., Tomé Saraiva, J., Hatziaargyriou, N., and Jenkins, N. (2003). "Management of microgrids." *Proc., IJEE Conf. 2003*.
4. Venkataramanan, G., Illindala, M. S., Houle, C., Lasseter, R. H. (2002) "Hardware development of a laboratory-scale microgrid. Phase 1: Single inverter in island mode operation." *Rep. No. SR-560-32527*, National Renewable Energy Laboratory, Golden, Colo.
5. Williams, C. (2003). "CHP systems." *Distributed Energy*, 57-59. Zhang, H., Chandorkar, M., Venkataramanan, G. (2003). "Development of static switchgear for utility interconnection in a microgrid." *Proc., Power and Energy Systems*.
6. Costa P.M., Matos M.A. "Reliability of Distribution Networks with Microgrids", Proceedings of PowerTech 2005, St. Petersburg, June 2005.
7. S. Papathanassiou, D. Georgakis, N Hatziaargyriou, A. Engler, Ch. Hardt, "Operation of a prototype Microgrid system based on MicroSource equipped with fastacting power electronic interfaces", 31th PESC, Aachen, June 2004.
8. A. Engler, "Applicability of droops in low voltage grids", Der Journal NO. 1, January, 2005

AUTHOR PROFILE



Prof. Murari Lal Azad, has done graduation and post graduation and Doctorate in Engineering from reputed Universities of India and has published papers in various international referred journals in the field of power system operation and control. The area of interest is power quality improvement.



Mr. Aizad Khursheed, has done his graduation and post graduation in Engineering from Jamia Millia Islamia, New Delhi. His research area is Power System Operation and Control (Microgrid) and Power Quality



Mr. S. Vikram Singh, has done his graduation and post graduation in Engineering from reputed Universities. His research area is Power System Operation and Control (Microgrid) and Power Quality.