

The Shunt Active Power Filter to Compensate Reactive Power and Harmonics with Optimized PI controller in a 3 Phase 3 Wire Distribution Network

Swapnil S. Managule, Sanjay Dabhole, Sanjeev Gupta

Abstract: In this paper is to study the denomination Power quality and large refers to maintaining a proximal sinusoidal power distribution bus voltage at rated magnitude and frequency. This is mainly affected by the generation of harmonics. Even though electronic and non-linear devices are flexible, economical and energy efficient, they may degrade power quality by creating harmonic currents and consuming excessive reactive power. A family of various shunt hybrid active power filters has been explored in shunt and series configurations to compensate for different types of nonlinear loads. They provide controlled current injection to remove harmonic current from the source side of electric system and also can improve the power factor. This paper shows the method of improving the power quality using shunt active power filter with proposed optimized PI. The proposed topic comprises of PI controller, filter hysteresis current control loop, dc link capacitor. The switching signal generation for filter is from hysteresis current controller techniques. With the all these element shunt active power filter reduce the total harmonic distortion. Its source current, compensating current and THD values are studied, then PI control strategy is applied then the differences in THD are compared. The PI feedback compensation design starts with the small signal system's transfer function. Then an optimum constant of PI for a Shunt-APF is proposed and implemented to enhance its response to compensation of harmonics of linear and non-linear loads. The obtained results have demonstrated the ability to compensate the current harmonics effectively under distorted source conditions. The fluctuation in the dc bus voltage of the filter depends on the compensation speed of the outer loop that regulates the dc bus voltage. The proposed shunt active filter model uses balanced linear and non-linear load works successfully lowers the THD within IEEE norms and satisfactorily works to compensate current harmonics. The model is made in MATLAB / SIMULINK and successfully reduces the harmonic in the source current.

Keywords: (Active Power Filter, threshold harmonics distortions, quality factor, transfer function, hysteresis etc.)

I. INTRODUCTION

1. Introduction
2. Simulation of three phases three wire Shunt Active Power Filter using optimal PI control strategies for balanced and unbalanced loads is carried out using MATLAB SIMULINK:

Manuscript published on 30 January 2018.

*Correspondence Author(s)

Mr. Swapnil S. Managule, M.Tech. Scholar, Department of Electronics Engineering, Sarvepalli Radhakrishnan University, Bhopal (M.P), India. E-mail: swapnilmanagule@gmail.com

Dr. Sanjay Dabhole, Professor and Head, Department of Electronics Engineering, Walchand College of Engineering, Sangli (Maharashtra), India.

Dr. Sanjeev Gupta, RKDF Institute of Science and Technology (RKDFIST), Bhopal (M.P) India.

© The Authors. Published by Blue Eyes Intelligence Engineering and Sciences Publication (BEIESP). This is an [open access](https://creativecommons.org/licenses/by-nc-nd/4.0/) article under the CC-BY-NC-ND license <http://creativecommons.org/licenses/by-nc-nd/4.0/>

- a) p-q theory
 - i. Constant instantaneous power control strategy
 - ii. Sinusoidal current control strategy
 - iii. Generalized Fryze current control strategy
- b) d-q theory
 2. Simulation to study the performance of shunt Active Power Filter for balanced and unbalanced loads
 3. Performance Analysis is carried out for Shunt Passive Filter) for balanced and unbalanced load, under different conditions using MATLAB SIMULINK and all the results are compared to find the best suitable solution.
 2. THD% and power factor calculations done for all the simulation models

This chapter gives the overview of the work. This comprises of a brief description of power quality, harmonic sources and effects followed by literature survey. The objectives and organization of the thesis are mentioned in this chapter.

1.1. Background

1.1.1. Power Quality

The PQ issue is defined as “any occurrence manifested in voltage, current, or frequency deviations that results in damage, upset, failure, or mis-operation of end-use equipment.” Almost all PQ issues are closely related with PE in almost every aspect of commercial, domestic, and industrial application. Equipment using power electronic device are residential appliances like TVs, PCs etc. business and office equipment like copiers, printers etc. industrial equipment like programmable logic controllers (PLCs), adjustable speed drives (ASDs), rectifiers, inverters, CNC tools and so on. The Power Quality (PQ) problem can be detected from one of the following several symptoms depending on the type of issue involved.

- Lamp flicker
- Frequent blackouts
- Sensitive-equipment frequent dropouts
- Voltage to ground in unexpected
- Locations
- Communications interference
- Overheated elements and equipment.

PE are the most important cause of harmonics, inter harmonics, notches, and neutral currents. Harmonics are produced by rectifiers, ASDs, soft starters, Electronic ballast for discharge lamps, switched-mode power supplies, and HVAC using ASDs.



The Shunt Active Power Filter to Compensate Reactive Power and Harmonics with Optimized PI controller in a 3 Phase 3 Wire Distribution Network

Equipment affected by harmonics includes transformers, motors, cables, interrupters, and capacitors (resonance). Notches are produced mainly by converters, and they principally affect the Electronic control devices. Neutral currents are produced by equipment using switched-mode power supplies, such as PCs, printers, photocopiers, and any triplets generator. Neutral currents seriously affect the neutral conductor temperature and transformer capability. Inter harmonics are produced by static frequency converters, cyclo-converters, induction motors & arcing devices.

Equipment presents different levels of sensitivity to PQ issues, depending on the type of both the equipment and the disturbance. Furthermore, the effect on the PQ of electric power systems, due to the presence of PE, depends on the type of PE utilized. The maximum acceptable values of harmonic contamination are specified in IEEE standard in terms of total harmonic distortion.

Power electronics are alive and well in useful applications to overcome distribution system problems. Power electronics has three faces in power distribution: one that introduces valuable industrial and domestic equipment; a second one that creates problems; and, finally, a third one that helps to solve those problems. On one hand, power electronics and microelectronics have become two technologies that have considerably improved the quality of modern life, allowing the introduction of sophisticated energy-efficient controllable equipment to industry and home. On another hand, those same sensitive technologies are conflicting with each other and increasingly challenging the maintenance of quality of service in electric energy delivery, while at the same time costing billions of dollars in lost customer productivity.

1.1.2. Solutions to Power Quality Problems

There are two approaches to the mitigation of power quality problems. The first approach is called load conditioning, which ensures that the equipment is made less sensitive to power disturbances, allowing the operation even under significant voltage distortion. The other solution is to install line-conditioning systems that suppress or counteract the power system disturbances. Passive filters have been most commonly used to limit the flow of harmonic currents in distribution systems. They are usually custom designed for the application. However, their performance is limited to a few harmonics, and they can introduce resonance in the power system. Among the different new technical options available to improve power quality, active power filters have proved to be an important and flexible alternative to compensate for current and voltage disturbances in power distribution systems. The idea of active filters is relatively old, but their practical development was made possible with the new improvements in power electronics and microcomputer control strategies as well as with cost reduction in electronic components. Active power filters are becoming a viable alternative to passive filters and are gaining market share speedily as their cost becomes competitive with the passive variety. Through power electronics, the active filter introduces current or voltage components, which cancel the harmonic components of the nonlinear loads or supply lines, respectively. Different active power filters topologies have been introduced and many of them are already available in the market.

1.2. Harmonic Power Filters

The steady increase in non-linear loads on the power supply network raises question about power quality and reliability. The challenge is knowing how to select and deploy harmonic filters correctly to achieve satisfactory performance. In this chapter we discuss about different non-linear loads and what kind of filters must be used to effectively mitigate harmonics in the system.

1.2.1. Current Source Non-Linear Load

Thyristor converters are a common and typical source of harmonic currents. Fig. 2.1(a) shows a thyristor rectifier where a sufficient dc inductance produces a dc current. Therefore, it is called a current-source nonlinear load and represented as a current source shown in Fig. 2.1(b). Similarly, diode rectifiers with a sufficient dc inductance, a highly inductive load with silicon-controlled rectifier (SCR) ac power control, etc., are current-source nonlinear loads.

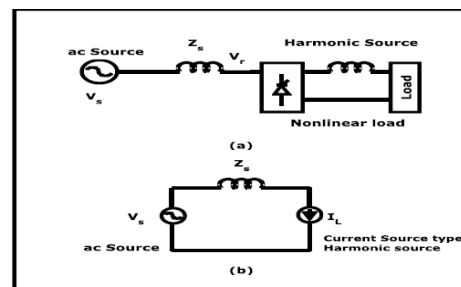

Figure 2.1: Typical CSNL

1.2.2. Voltage Source Non-Linear Load

Another common type of harmonic source is a diode rectifier with smoothing dc capacitors, as shown in Fig. 2.2(a). Therefore, the diode rectifiers behave like a voltage source, rather than a current source. Fig. 2.2(b) shows the equivalent circuit of the diode rectifier system where the diode rectifier is represented as a harmonic voltage source or voltage-source nonlinear load.

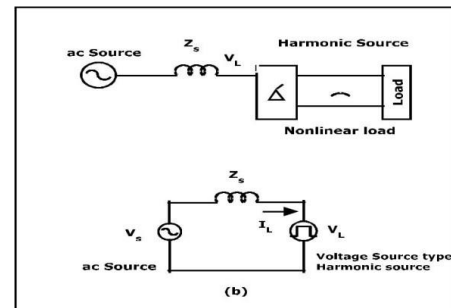

Figure 2.2: Typical VSNL

1.2.3. Types of Power Filter

There are different types of power filter [7]; analyzing the current situation power filters widely classified into three categories, Fig 2.3 shows these categories of power filters.

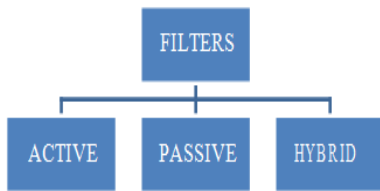

Figure 2.3: Types of power filters

1.3. Shunt Active Power Filter

The shunt-connected active power filter, with a self-controlled dc bus, has a topology similar to that of a static compensator (STATCOM) used for reactive power compensation in power transmission systems. Shunt active power filters compensate load current harmonics by injecting equal-but opposite harmonic compensating current. In this case the shunt active power filter operates as a current source injecting the harmonic components generated by the load but phase-shifted by 180°.

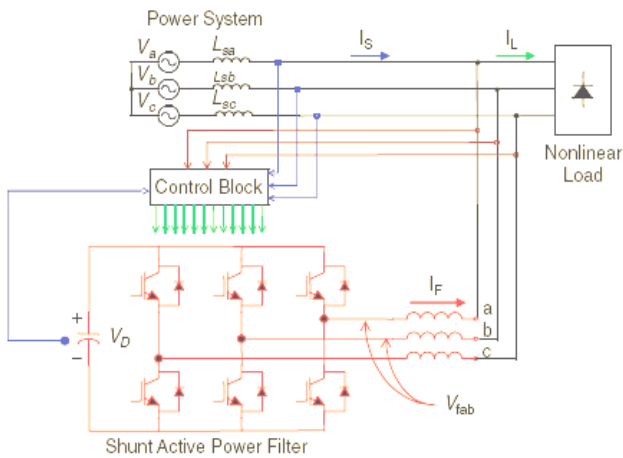

Figure. 3.1. Shunt Active Power Filter Topology

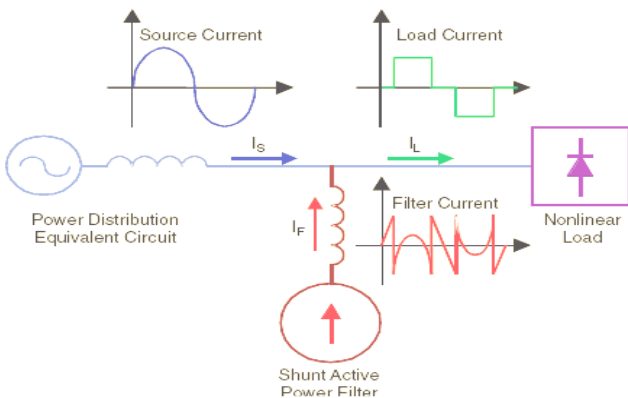

Figure.3.2. Filter Current I_F Generated to Compensate Load-Current Harmonics.

Figure 3.1 shows the connection of a shunt active power filter and Figure 3.2 shows how the active filter works to compensate the load harmonic currents.

1.4. PI Control Scheme

- Dc voltage control loop
- Transfer function of PWM converter
- Selection of PI controller parameters

The complete schematic diagram of the shunt active power filter is shown in figure 4.1. While figure 4.2 gives the control scheme realization. The actual capacitor voltage is

compared with a set reference value.

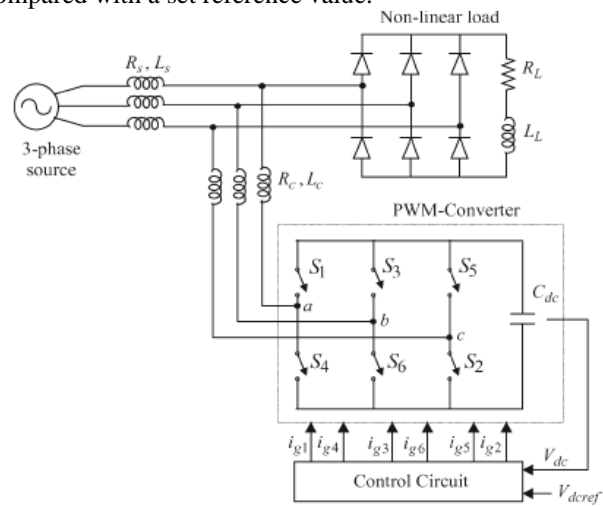

Figure. 4.1. Schematic Diagram of Shunt Active Filter

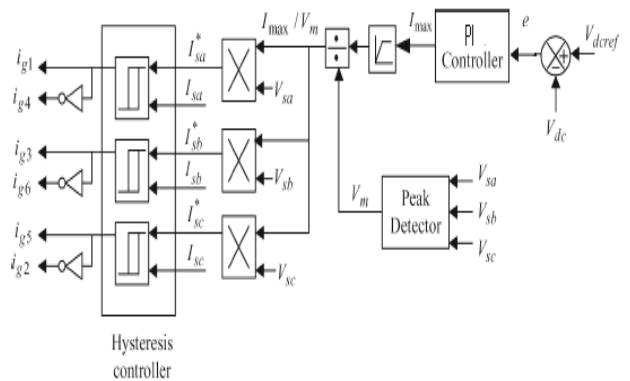

Figure. 4.2. APF Control Scheme with PI Controller.

The error signal is fed to PI controller. The output of PI controller has been considered as peak value of the reference current. It is further multiplied by the unit sine vectors (i_{sa} , i_{sb} , and i_{sc}) in phase with the source voltages to obtain the reference currents (i_{sa}^* , i_{sb}^* , and i_{sc}^*). These reference currents and actual currents are given to a hysteresis based, carrierless PWM current controller to generate switching signals of the PWM converter[2]. The difference of reference current template and actual current decides the operation of switches. To increase current of particular phase, the lower switch of the PWM converter of that particular phase is switched on, while to decrease the current the upper switch of the particular phase is switched on. These switching signals after proper isolation and amplification are given to the switching devices. Due to these switching actions current flows through the filter inductor L_c , to compensate the harmonic current and reactive power of the load, so that only active power drawn from the source.

II. LITERATURE REVIEW

The literature study for this work starts from Harmonic sources and filtering approaches [1-6] wherein it is described that non-linear loads can be characterized into two types of harmonic sources: current source type non-linear loads and voltage type of non-linear loads.



The Shunt Active Power Filter to Compensate Reactive Power and Harmonics with Optimized PI controller in a 3 Phase 3 Wire Distribution Network

These two types of harmonic sources have completely distinctive and dual properties and characteristics. Brief study of Hybrid filters and various shunt and series configurations of hybrid filters have been explored in [7-8]. The Modeling is necessary whenever analysis of control system is required [9]. The total modeling of three phase SH-APF is described in this paper followed by dq-transform [10].

In the paper titled "Lyapunov-function based control for a three-phase shunt hybrid active power filter", S. Rahemani, A. Hamadi and K. Al. Haddad a Lyapunov control technique is developed for a three-phase SH-APF to compensate harmonics generated by non-linear loads and is applied for balanced operation. Liu. Wei and Zhang Da-wei have discussed about series hybrid active power filter based on PID controller [11-13]. Gating signal techniques have been discussed in papers [14-15], then PWM techniques have been discussed in [17]. A new control strategy for single phase shunt APF's is proposed based on Lyapunov's stability theory [18-19]. The theoretic analysis by reference current generating method by Jia Zhang, Guohong Zeng [20] can reduce reactive and harmonic current effectively.

Jarupula Somlal discussed efficient improvement of Power Factor and Harmonic suppression using MATLAB [21]. Control strategies of SH-APF using fuzzy logic, neural networks and swarm organization have been proposed in these papers [22-23].

Early equipment was designed to withstand disturbances such as lightning, short circuits, and sudden overloads without extra expenditure. Current power electronics (PE) prices would be much higher if the equipment was designed with the same robustness. Pollution has been introduced into power systems by nonlinear loads such as transformers and saturated coils; however, perturbation rate has never reached the present levels. Due to its nonlinear characteristics and fast switching, PE create most of the pollution issues. Most of the pollution issues are created due to the nonlinear characteristics and fast switching of PE. Approximately 10% to 20% of today's energy is processed by PE; the percentage is estimated to reach 50% to 60% by the year 2010, due mainly to the fast growth of PE capability. A race is currently taking place between increasing PE pollution and sensitivity, on the one hand, and the new PE-based corrective devices, which have the ability to attenuate the issues created by PE, on the other hand. Methodology-

The body of this thesis consists of the following chapters-

- In a description of the structure of the shunt active power filter, the basic compensation principle, how reference source current is estimated and role of DC side capacitor is given.
- The PI control scheme of shunt active power filter in which DC voltage control loop design and how to select PI controller parameters is presented.
- And also deals with the fuzzy logic, fuzzy logic controllers and implementation of fuzzy control scheme for shunt active power filter. In this chapter basic fuzzy algorithm and design of control rules is also described.
- The entire active filter system is composed mainly of a three-phase source, a non-linear load, a voltage source PWM converter, and a PI or fuzzy controller. All these components modeling is described separately in chapter 2.
- Simulation results are put and discussed in detail.

Proposed model with optimized PI controller performances are compared under certain conditions.

- The conclusions of the thesis and recommendations for future work are summarized.

III. SIMULATION AND IMPLEMENTATION

5.1. System design constraints for shunt APF:

Supply voltage:

$V_{ph} = 100V$ (rms value).

Source impedance:

$R_s = 3.6 \Omega$.

$L_s = 5.8pH$.

Supply frequency:

$f_s = 50$ Hz.

Compensator parameters:

$V_{dc} = 210$ V.

$C_{dc} = 40pF$.

$L_f = 1.2$ mH.

Regular load

$R_L = 25 \Omega$.

$L_L = 55mH$

Linear load parameters:

$R = 10 \Omega$.

Non-linear load parameters:

$R = 25 \Omega$.

$L = 12$ mH.

$C = 2200 \mu F$.

- This model is three phase wire system it does not have a common or neutral wire and so there is no zero sequence current components. Therefore there is no sinusoidal or symmetrical source current.

• Z_t is used because the PWM current controller forces inverter to simulate a controlled current source. In order to avoid high inductive kick, the coupling of shunt APF to the load must be made through inductor Z_t known as commutation inductor.

- circuit breakers are used to set operate APF at 0.02 delay in order to incorporate before and after compensation affects or negative sequence currents wipe out completely since all imaginary power would be compensated.

• According to Pq theory, only active and reactive power exist because this system has no neutral, zero sequence power is not present. The DC section 10 ohm resistor compensates or limits reactive power.

• Another circuit breaker is used at PCC with transition time 0.01. That means after 0.01, circuit breaker is closed and shunt APF is connected to the system. So between time 0 and 0.01, waveform must be much more distorted, because the APF is not connected that time. But I observe that the nature of waveform is same throughout.

APF is switched on at 0.02 seconds after compensation the source current has become a single frequency pure sinusoid having THD equal to 3.02% at 50 hz. circuit breakers are used to set operate APF at 0.02 delay in order to incorporate before and after compensation affects or negative sequence currents wipe out completely since all imaginary power would be compensated.

Nature of waveform same because positive sequence current would remain unaltered since they are responsible for active power transfer to the load.

- As operating freq becomes 50hz, we put max. freq. 100. And time from 0.02 to 2.0 as our APF operates at 0.02 and have unaltered positive current my interests to see Ten cycles you can try for different for sake of waveform display only think is while selecting cycles initial time should covered (here 0.2 so put initial time 0.0 so on).

- Pi controller is used to remove steady state error. Here you must maintain Vdc by comparing it with constant value Vref. If Vdc (here less than 100v) is lesser than Vref (hence it 220v) then it would create a positive Ploss signal and if Vdc is greater than Vref. It would create negative Ploss signal.

- analog filter is used to implement 5th order butterworth filter with cut off freq. $2\pi \cdot 50$. This is used to filter out the components of active power transferred only due to the fundamental current component.

- Coupling inductor is used to couple power inverter with Point of common coupling (PCC). Its job is to limit Ldi/dt effects.

- DC capacitors are discharged through the inverter to generate compensation currents. These capacitors then become the source of harmonics rather than the main source.

3.1. Non-linear Unbalanced Load:

- Here, we tried to implement constant Instantaneous strategy where only active avg. real from the load is used and remaining power (from harmonics is exchanged with shunt APF). Shunt APf works on closed loop manner, continuously acquiring the samples of load current and calculating the instantaneous values of compensating current as ref. i^*c for the PWM converter.

- The presence of constant instantaneous active power is due to the positive sequence current in case of pure resistive unbalanced load and constant imaginary power due to positive sequence current due to inductive/capacitive unbalanced load. The presence of oscillations is due to negative sequence current in both cases.

Here load is capacitive which generates a negative sequence current, to limit this negative current we connect 10 ohm resistor.

- Nonlinear unbalanced load consisting of three single-phase diode rectifiers with parallel RC-load having different values on each phase as below.

Where, $R1 = 16.67\Omega$, $C1 = 2200\mu F$

$R2 = 25\Omega$, $C2 = 2200\mu F$

$R3 = 50\Omega$, $C3 = 2200\mu F$

- In short Circuit breakers and PCC are used for selective compensation characteristics and set operate APF at 0.02 delays in order to incorporate before and after compensation affects.

IV. RESULTS

Table-1 Observed Results for Balanced Load:

Sr. No	Parameter	Obtained Results
1.	Source Voltage (Vs)	45.99V
2.	Source Current (Is)	4.55A

3.	Load Voltage (Vload)	45.99V
4.	Load Current (Iload)	1.972 A
5.	Power Factor (PF)	0.9968

Table-2 Observed Results for Un-balanced load:

Sr. No	Parameter	Obtained Results
1	Source Voltage (Vs)	18.61V
2.	Source Current (Is)	5.79A
3.	Load Voltage (Vload)	18.61V
4.	Load Current (Iload)	3.04A
5.	Powe Factor (PF)	0.995

Result From Waveforms:

The oscillations in both the power is due to the unbalanced load condition due to which a negative sequence current is also present.

1. Presence of constant instantaneous active power is due to the positive sequence current and only in case of purely resistive loan but may be unbalance.

2. The presence of constant instantaneous imaginary power is due to the positive sequence current and only in the case of pure inductive load but may be unbalance

3. The presence of oscillations in both of instantaneous powers is due to the negative sequence current whether a load is purely resistive or inductive

From FFT analysis

When PI constant becomes 210.

- As per IEEE 519 harmonics limit THD for balanced load case becomes 5.52% which is technically correct as its in acceptable range

- As per IEEE 519 harmonics limit THD for Un-balanced RC load case becomes 3.05% which is technically correct as its in acceptable range

- As per IEEE 519 harmonics limit THD for Un-balanced RLC load case becomes 6.41% which is technically correct as it's in acceptable range.

- As per IEEE 519 harmonics limit THD for Un-balanced RLC load case becomes 7.25% which is technically correct as it's in acceptable range.

Table-3 Result of Balanced Load for Different PI Constant

PI constant	VS	IS	VL	IL	P.F.	THD
150	54.4	3.7	54.4	2.55	1	3.41%
170	51.85	5.88	51.85	1.45	0.93	3.16%
190	43.55	6.5	43.55	2.4	0.92	3.70%
210	35.9	6.8	35.9	2.03	0.9	2.35%
230	37.99	6.48	37.99	2.17	0.92	5.52%
250	91.91	6.0	91.91	1.85	-0.57	8.60%

The Shunt Active Power Filter to Compensate Reactive Power and Harmonics with Optimized PI controller in a 3 Phase 3 Wire Distribution Network

Table-4 Results of Unbalanced RC Load for Different PI Constant

PI constant	VS	IS	VL	IL	P.F.	THD
150	10.4	7.4	10.4	1.9	0.93	2.70%
170	10.4	7.4	10.4	1.9	0.90	2.65%
190	43.5	6.5	43.5	2.4	0.92	3.70%
210	35.9	6.8	35.9	2.0	0.98	2.31%
230	78.8	6.1	78.8	1.6	0.80	4.39%
250	94.8	6.2	94.86	1.6	0.047	8.22%

Table-5 Results of Unbalanced RL Load for Different PI Constant

PI constant	VS	IS	VL	IL	P.F.	THD
150	10.4	7.4	10.4	1.9	0.93	2.70%
170	10.4	7.4	10.4	1.9	0.90	2.67%
190	10.4	7.4	10.4	1.9	0.90	2.62%
210	9.6	7.4	9.6	1.7	0.90	2.61%
230	9.8	7.4	9.8	1.8	0.90	2.61%
250	10.2	7.4	10.2	1.9	0.89	2.64%

Table-6 Results of Unbalanced RLC load for Different PI Constant

PI constant	VS	IS	VL	IL	P.F.	THD
150	53.17	3.76	53.17	2.58	0.94	3.60%
170	52.33	5.89	52.33	1.82	0.93	3.60%
190	34.04	6.15	34.04	2.34	0.91	6.75%
210	37.76	5.84	37.76	2.23	0.96	2.20%
230	33.46	6.25	33.46	1.85	0.93	4.16%
250	84.04	5.21	84.04	2.04	-0.97	6.91%

V. CONCLUSION

Presence of constant instantaneous active power is due to the positive sequence current and only in case of purely resistive load but may be unbalance.

The presence of constant instantaneous imaginary power is due to the positive sequence current and only in the case of pure inductive load but may be unbalance. The presence of oscillations in both of instantaneous powers is due to the negative sequence current whether a load is purely resistive or inductive. From FFT analysis and table 1 to 4 seems that the proposed shunt-APF system with optimized PI system along constant 210 outperform for balanced and unbalanced configuration load (R,RC,RL and RLC) for unique power factor.

REFERENCES

1. H. Akagi "New trends in active filters for power conditioning,"IEEE Trans. Ind. Appl.,Vol. 32, No. 6,pp. 1312-1322, Nov./Dec.1996.
2. F. Z. Peng, G. W. Ott Jr., D. J. Adams, "Harmonic and reactive power compensation based on the generalized instantaneous reactive power theory for three-phase four-wire systems" IEEE Trans. Power Electron.,Vol. 13, No. 5, Nov. 1998.
3. M. I. M Montero, E. R. Cadaval, and F. B. Gonzalez, "Comparison of control strategies for shunt active power filters in three-phase four-wire systems,"IEEE Trans. Power Electron., Vol. 22, No. 1, Jan. 2007.
4. W. M. Grady, M. J. Samotyj, and A. H. Noyola, "Survey of active power line conditioning methodologies," IEEE Transactions on Power Delivery, vol. 5, no. 3, Jul. 1990, pp. 1536-1542.
5. H. Akagi, Y. Kanazawa, and A. Nabae, "Instantaneous reactive power compensators comprising switching devices without energy

6. storage components," IEEE Transactions on Industry Applications, vol. IA-20, no. 3, May/Jun. 1984, pp. 625-630.
7. S. Jain, P. Agarwal, and H. O. Gupta, "Design simulation and experimental investigations on a shunt active power filter for harmonics and reactive power compensation," Electrical Power Components and Systems, vol. 32, no. 7, Jul. 2003, pp. 671-692.
8. F. Z. Peng, H. Akagi, and A. Nabae, "Study of active power filters using quad series voltage source PWM converters for harmonic compensation," IEEE Transactions on Power Electronics, vol. 5, no. 1, Jan. 1990, pp. 9-15.
9. H. Akagi, "Trends in active power line conditioners," IEEE Transactions on power Electronics, vol 9, no 3, 1994, pp 263-268.
10. S. K. Jain, P. Agrawal, and H. O. Gupta, "Fuzzy logic controlled shunt active power filter for power quality improvement," Proceedings of Institute of Electrical Engineers, Electrical Power Applications, vol. 149, no. 5, 2002.
11. L.A.Morgan, J.W.Dixon&R.R.Wallace, "A three phase active power filter operating with fixed switching frequency for reactive power and current harmonics compensation," IEEE Transactions on Industrial Electronics, vol.42, no.4, August 1995, pp 402-408.
12. H. Akagi "New trends in active filters for power conditioning,"IEEE Trans. Ind. Appl.,Vol. 32, No. 6, pp. 1312-1322, Nov./Dec.1996.
13. F. Z. Peng, G. W. Ott Jr., D. J. Adams, "Harmonic and reactive power compensation based on the generalized instantaneous reactive power theory for three-phase four-wire systems" IEEE Trans. Power Electron.,Vol. 13, No. 5, Nov. 1998.
14. V. Soares, P. Verdelho, and G. Marques, "Active power filter control circuit based on the instantaneous active and reactive current id-iq method,"IEEE Power Electronics Specialists Conference, Vol. 2, pp M Suresh, A. K. Panda, S. S. Patnaik, and S. Yellarsi, "Comparison of two compensation control strategies for shunt active power filter in three-phase four-wire system," in Proc. IEEE PES Innovative Smart Grid Technologies, pp. 1-6, 2011.
15. Fang Zheng Peng and Akagi, (1990), "A New Approach to harmonic Compensation in Power Systems A combined System of Shunt Passive and Series Active Filters", IEEE Transactions on Industrial Applications, Vol. 26, pp-6-11.
16. Karuppanan P and Kamala kanta Mahapatra (2011), "PI with Fuzzy Logic Controller based Active Power Line Conditioners"- Asian Power Electronics, Vol. 5, pp-464468.
17. Suresh Mikkili and Panda A.K. (2011), " PI and fuzzy logic controller based 3-phase 4-wire shunt active filter for mitigation of current harmonics with Id-Iq control strategy", Power Electronics (JPE), Vol.11, pp-914-21.
18. Suresh Mikkili, Panda A.K. (2012), "Real-time Implementation of PI and Fuzzy logic controllers based shunt active filter control strategies for power quality improvement", ELSEVEIR:Electrical Power and Energy System, Vol.43, pp-1114-1126.
19. Saad S and Zellouma L. (2009), "Fuzzy logic controller for three-level shunt active filter compensating harmonics and reactive power". Electronics Power System Research, Vol.79, pp-1337-1341.
20. S. K. Jain, P. Agrawal, and H. O. Gupta, "Fuzzy logic controlled shunt active power Filter for power quality improvement," Proceedings of Institute of Electrical Engineers,Electrical Power Applications,vol. 149, no. 5, 2002.
21. Rodriguez P, Candela J.I, Luna A and Asiminoaei L. (2009), " Current harmonics cancellation in three-phase four-wire systems by using a four-branch star filtering Topology", IEEE Transactions on Power Electronics, Vol. 24, pp-1939-50.
22. Kirawanich P and O, Connell R.M. (2004), "Fuzzy Logic Control of an Active Power Line Conditioner", (2004), IEEE Transactions on Power Electronics, Vol. 19, pp-1574-1585.
23. Zaniyal Salam, Tan Perng Cheng and Awang Juosh. (2006),"Harmonics Mitigation using Active power Filter: A Technological Review"- Elekrika Vol. 8, pp-17-26.
24. P. Kirawanich and R. M. O'Connell, "Fuzzy logic control of an active power line conditioner,"IEEE Trans. Power Electron. Vol. 19, No.6, pp. 1574-1585, Nov. 2004.