

# IoT based Security System using Raspberry PI and Mail Server

S. Snigdha, K. Haribabu

**Abstract:** This project approach with the IoT Integration of Internet Security Integration with a mail server. The project aims to increase the safety of homes with the help of the above mentioned methods. This approach focuses on transmitting data and sensors, instructions, cameras, and end-users through the inclusion of a spying device into a small Raspberry Pi. IoT can be seen as an growth rather than a revolt. IoT includes the use of connections for effective collection and analysis of data from various sensors or personal computers through wireless connection. Built in today's system, sends an owner of Internet Advertising ads if changes are made, and clicks on people that cause user-alerts. This system includes also providing for the appropriate informed security personnel in case of an emergency.

**Keywords:** Raspberry Pi, SMTP Server, Smart Home, Weather Conditions.

## I. INTRODUCTION

Internet of Things concept of remote connection and control of reality through the Internet. When it comes to our home, this idea can be integrated to make it more secure, more secure, and more automated. Home wireless security and home automation - Two aspects of the project. Built in today's system, sends the model owner of advertisements using the internet, if the movement of any person's traffic is felt near the entrance to his home and annoyed by the user. This system includes also providing for the appropriate informed security personnel in case of an emergency. So using the similar set of sensors, two home safety then home automation difficulties can be resolved on the basis of many more. My project focus - to help users control their smartphone accessories.

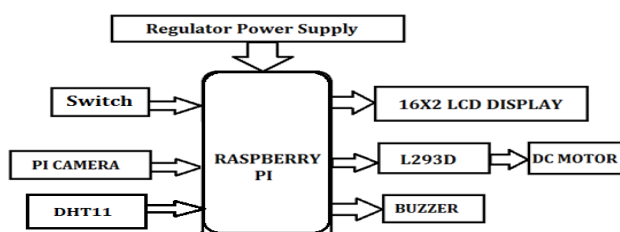

The Internet allows you to use your home, and check it from the distant world. The whole contents of this smart home - do simple, even simple tasks. Home automation and smart home automation can be considered as home-based technology for the convenience, comfort and safety of its people.

Manuscript published on 30 September 2019.

\*Correspondence Author(s)

S. Snigdha, PG Scholar, Dept of ECE, MLRIT, Dundigal, Hyderabad  
K. Haribabu, Project Guide, Asst. Prof, Dept of ECE, MLRIT, Dundigal, Hyderabad

© The Authors. Published by Blue Eyes Intelligence Engineering and Sciences Publication (BEIESP). This is an open access article under the CC-BY-NC-ND license <http://creativecommons.org/licenses/by-nc-nd/4.0/>

Retrieval Number: K15170981119/19@BEIESP  
DOI: 10.35940/ijitee.K1517.0981119  
Journal Website: [www.ijitee.org](http://www.ijitee.org)

With the introduction of IoT, research and home automation practices have become increasingly popular. The Internet of Things (IoT) can be regarded as the connection of everyday objects such as smart phones, Internet TV sets, sensors and actuators to the Internet, where the device is properly interconnected, allowing you To create a new form of communication between people and people, as well as others. IoT construction has improved dramatically over the past few years as he works with new dimensions to the world of information, communication and communication. The main purpose of the system is to provide users with automated automation of home. Needed to use home appliances to allow users to take advantage of technology in ways that one can send a learner to an indoor control center, I forget to turn off devices such as supporters and firefighters, not to come home.

## II. LITERATURE REVIEW

Published in July 2014, the B + version are an up to date version of version B. It will increase the number of USB ports to four and the variety of pins on the GPIO header to 40. Similarly, an improved electricity circuit that lets in a better strength delivers USB devices to connect and now hot plugged. The total composite video connector has been eliminated and the functionality has been moved to the three.5 mm audio / video jack. The good sized SD card slot has also been changed with a far greater strong micro SD slot.

## III. DESCRIPTION

The main purpose of the system is to provide users with automated automation of home. Needed to use home appliances to allow users to take advantage of technology in ways that one can send a learner to an indoor control center, I forget to turn off devices such as supporters and firefighters, not to come home. Remote home systems can include central lighting management, fan support, and other security systems that provide increased convenience, comfort, and energy security. This is the main reason for the development of this system is that it saves time and effort, as well as ensuring security and convenience. Because this automated system is useful for people to ensure their safety, comfort, and easy access. The app will allow users to monitor devices connected to either of these two integrated utilities. The focus of the program will be sent to a security system with video surveillance, alarm detection and light management. The purpose of our system is to take care of many internal systems, which can usually be difficult for those who are disabled or the elderly.



Published By:  
Blue Eyes Intelligence Engineering  
and Sciences Publication (BEIESP)  
© Copyright: All rights reserved.

Suggested ideas will allow you to use any supported device for Android to run applications for download on any mobile device, such as a smartphone. This device is attached to the home appliance with the Pi so that they can be monitored and controlled. Suppose the staff who went to work with and during this time the house of the theft of thieves. The proposed system will allow customers to monitor their homes when the door or windows of the sensors are scary. The client manages his home with the help of a webcam and can notify your local authorities or police immediately. Customers can check the status of external light and change the light on and off without having to get out of bed. These devices also benefit users with reduced mobility that may be difficult to obtain or even reach light changes. These tasks require a lot of tech. The user interface should be simple and powerful and self-organizing the way to work.

## IV. METHODOLOGY

### A. Raspberry Pi Supply:

The device is control by mini 5V USB port. Normally, the model B used between 700-1000mA depends on what the peripheral device is connected to a model that can only be used without a 500mA peripherals. Raspberry Pi Maximum power can be used in amp 1. If you essential to attach a USB expedient that accepts greater than 1 power requirement, you must link it to the external USB center nutrition. This raspberry pi energy requirement is as you use a different interface on raspberry pi. The GPIO speculation can be done safely to 50mA, be distributed to all the contacts down. Individual GPIO pin can only be 16 meters safely. This is a 50mA HDMI port, the camera unit needs 250mA and the keyboard and mouse can be as small as 100m or more 1000mA. Squared the power evaluation of the equipment you proposal to fix to Pi to make and buy power supplies respectively. The input of the circuit is supplied from the power supply. The entrance, for example, 230 from the power supply, is a step-down step to 12v and fed to the rectifier. The output obtained from this rectifier is the DC voltage. So as to get a DC voltage pure output since the rectifier fed to the filter to eliminate all components AC present yet after the correction. Now the voltage is provided by Voltage Regulator to obtain the pure steady DC voltage.

### B. Motor Driver:

L293 and L293D are currently four high-current, half-H drivers, designed to deliver dual-current drives up to 1 at 4.5 volts to 36 V. The L293D aims to provide a 2-way drive upstream of awake to 600 mA at 4.5V V 36b. Mutually devices are considered to drive all loads such as transistors, DC solenoid and stepper steering wheels and other current loads. High / high ions with positive energy applications. The circuit is called H-Bridge, since it appearances like the "H" H-Bridge's operating principle. If this change (A1 and A2) is switched on and changed (B1 and B2) are turned off, the motor rotates in the clock direction. If this change (B1 and B2) is turned on and this change (A1 and A2) is possible, the motor in counter clockwise directions. We can use a transistor switch.

### C. PI CAMERA:

In order to happen the requirements for the Raspberry Pi friendly camera module. Now the group has released the additional ArduCAM camera module for the Pi, which is officially compatible. Optical performance features more than two pre-existing cameras and offers users with lots of sharp and clear images. It provides a signal and FREX strobe, which can be usage to capture synchronization with the correct multi camera firmware.

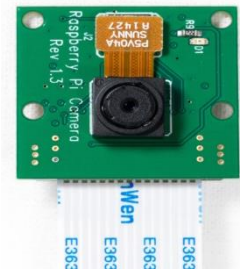

It connects to the Raspberry Pi with one of the two minor shops on the upper surface of the board. This interface uses a special CSI interface designed specifically for communicating with the camera. The CSI bus is very high, with data capacity and data pixel processing only. The camera is backed up by the newest form of Raspbian, the raspberry Pi operating system.

### D. SCHEMATIC DIAGRAM:

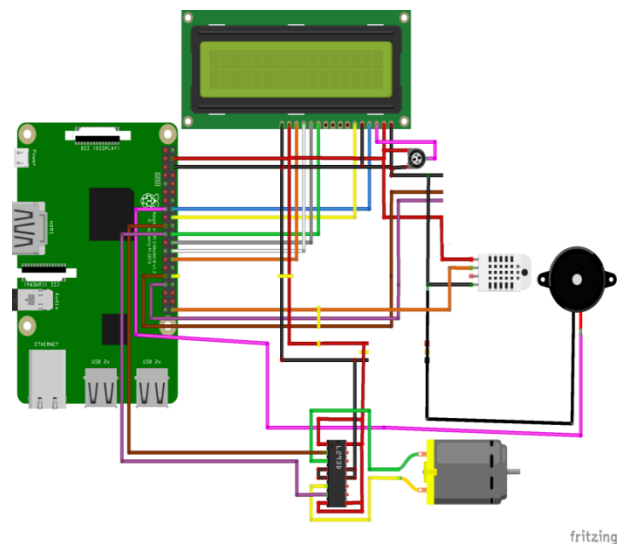

### V. ADVANTAGES:

- Save money, power and noise.
- We can also manage the device using the Internet as well on the long way, easily connected to the web service.
- That is, less time has been made to help the elderly. Smart home can make life easier and easier.

- Smart home, you're working or loosening, inform you about what's going on on security systems that can be built to provide a large amount of emergency relief.
- Smart home offers some energy savings. The power goes down when the power is automatically closed in an empty room and the room can be freezing depending on which one you have at any time.

**VI. CONCLUSION**

The technology used can be performed in a variety of applications that require a sensor and a device. The project has been successfully developed to connect a mobile device, such as a smartphone or laptop using the Raspberry Pi, for controlling the door and switches of light and camera to broadcast live video, but there are many possible applications that can take advantage of this. The ultimate goal of this file - to create a home security system using raspberry slices. So it can help people feel safe in their home, whether they are home. This project is based on the modern type of the Raspberry model, and the C language. It is low cost and can be easily managed. Even though our homes will experience their own home conversion, constant interaction with networks that constantly seek to improve energy management and full home automation to ensure comfort, safety and privacy.

**VII. FUTURE SCOPE**

Even though the final product is very successful in achieving its purpose, it should be remembered that industrial products. This is just a model and to create a productive market will do much. A few areas that need improvement, the size of the device, the cost of equipment used in power supply and contact range. Currently, no raspberries are too large to fit into an existing easy-to-access electricity unit. There are many ways this can be improved in the future. The use of SMD components greatly reduces the overall size of the component.

**REFERENCES**

1. Automated Intelligent relay coupled door control system using technology. By A. Rajesh Kumar , C. Dinesh , R. Aravind Vol 4, 16th May 2015
2. Mitchell, Gareth. "The Raspberry Pi single-board computer will revolutionize computer science teaching [For & against]." *Engineering & Technology* 7.3 (2012):26-26
3. International Journal of Innovative and Emerging Research in Engineering (IJIERE). Topic Name: Home Automation using Raspberry pi.

**AUTHOR'S PROFILES:**



I Studied B.Tech (ECE), Prinston Institution of Engineering and Technology for Women at Hyderabad. I am studying M.Tech (ES), MLR Institutions of Engineering at Hyderabad.



K. Hari Babu, Associate prof in dept of ECE, MLR Institute of technology, Hyderabad. Research area is Image and Video processing

