

A Smart Dustbin using Mobile Application

Anilkumar C.S., Suhas G, Sushma S



Abstract As there is a rapid increase in the present population waste management has become the serious problem in the current world. So in this paper we are proposed a new system of waste management using an android mobile app with Bluetooth enabled smart dustbin. This android application controlled bot through the lines drawn on the floor. Usually the lines are predefined throughout the path. The predefined paths may a white line on a black surface or vice-versa. The smart dustbin detects a person using IR sensor, if person is detected automatically it will open the cap of the dustbin and if he moves away from the dustbin it will automatically close the cap of the dustbin using stepper motor. It can also be able to detect amount of garbage and odour present in the dustbin using sensors. If any one of these things reached the threshold, it will automatically send a message to the concerned person through GSM module.

Keywords— Android application, Bluetooth module, robot and Ultrasonic sensor, IR sensor, Gas sensor, dustbin.

I. INTRODUCTION

In the present world many people are suffering from the infectious diseases due to the improper disposal of waste and it has become the most challenging task is to Keep the surroundings clean. keeping this as the main intension of our paper. We are in a fast growing society where science and technology sees a rapid growth and time has become the most valuable thing. In this proposed system the wireless line following robot embedded system is a high resolution and robustness. The Proposed work is embedded system having capability to perform particular programming. Usually the lines are predefined path. These path might be a white line on a black surface or black line on a white surface. Here we use ATmega328p microcontroller which acts as the brain of the robot. We have used 2 B.O. motors with 9v operating voltage for wheels of the robot, and 2 IR sensors' for line following purpose. And the robot is controlled using HC05 Bluetooth device without human interference. It also helps the physically disabled and aged person's. Disabled population in India as per census 2011 is out of the 12.1cr population 2.68cr persons are disabled which is 2.21% of the **total population(1)**. Proposed system forms a helping hand at home for those who cannot help themselves. Automated smart dustbin people can have a control on it through the wireless media using Bluetooth technology in the mobile. Whenever the dustbin reaches the threshold level automatically message will trigger on the concerned person mobile. So this process will avoid the human intervention.

Manuscript published on 30 September 2019.

*Correspondence Author(s)

Anilkumar C.S., Teaching Associate, School of ECE. REVA University. Bangalore-India.

Suhas G, UG Scholar, School of ECE. REVA University. Bangalore-India.

Sushma S, UG Scholar School of ECE. REVA University. Bangalore-India.

© The Authors. Published by Blue Eyes Intelligence Engineering and Sciences Publication (BEIESP). This is an [open access](http://creativecommons.org/licenses/by-nc-nd/4.0/) article under the CC-BY-NC-ND license <http://creativecommons.org/licenses/by-nc-nd/4.0/>.

Retrieval Number: K21290981119/19©BEIESP

DOI: 10.35940/ijitee.K2129.0981119

Journal Website: www.ijitee.org

II. RELATED WORK

- 1) "Obstacle Avoidance Robot":- This paper was given by [1] 1aamir attar, 2aadil ansari, 3abhishek desai, 4shahid khan, 5dipashri sonawale, the aim of this project is to build the obstacle avoiding robotic vehicle with the help of ultrasonic sensors and IR sensor. Here microcontroller (AT mega328p) helps to do all the operation of the bot.
- 2) This paper was proposed by [2] Kazi Mahmud Hasan, Abdullah-AI-Nahidd, Abdullah Al Mamun Hasan, This system is designed such that the device should identify the line and manoeuvres consequently along the path during correction of the wrong moves using feedback technique.
- 3) This paper was proposed by [3] Deepak Punetha, Neeraj Kumar, Vartika Mehta this system has been designed for a robotic competition. Colak I. et.al designed a line follower bot to make use of it in the malls for entertaining purpose. This device uses 4.8 cm wide black line and can carry load upto 400 kg. They can also be controlled manually through remote controller.
- 4) This paper was proposed by [4] Anil Kumar C.S Dr.Venkata Siva Reddy. R "Smart Solid & Liquid Waste Management Using Internet of Things" in work Smart solid waste management system has been designed which checks the status and alerts the fullness of dustbin and more significantly system has a feature to make use of dustbin properly.
- 5) This paper was proposed by Gopal Krishna Shyam, Sunil kumar S. Manvi, Priyanka Bharti this system based on waste management by providing intelligence to dust bins with the help of IoT and sensors. This system collect and transfer huge amount of data over the Internet.
- 6) This paper was proposed by Bharadwaj B, M Kumudha, Gowri Chandra N " Chaitra G "automation of smart waste management with the help of IoT in the provision swachh bharaat abhiyan" it helps in the waste management using smart dust bins by IoT.

III. PROBLEM STATEMENT

Based on the literature review exists problem in the waste management is as follows:-

- There is no moving dustbin available in the market.
- It makes work simple for Physically challenged persons and aged persons are unable to use in the dustbin
- Inappropriate placement of dustbin in the surrounding.



Published By:

Blue Eyes Intelligence Engineering

and Sciences Publication (BEIESP)

© Copyright: All rights reserved.

A Smart Dustbin using Mobile Application

- None of the system contains real time tracking status of the fullness of the bins.
- No dust bins are present that can detect the odour caused by the bins.

IV. BLOCK DIAGRAM

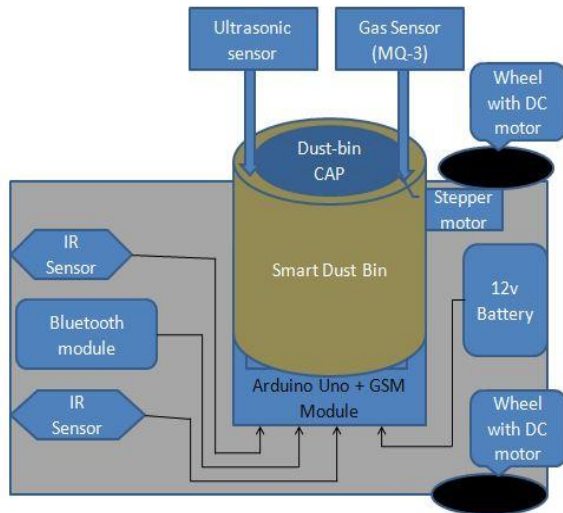

Fig1: block diagram of smart dustbin

This proposed system includes numerous technologies integrated in it, such as

- IR sensors
- Ultrasonic sensors module
- Gas sensor
- GSM module
- Bluetooth
- Arduino uno
- 12v DC battery for GSM module
- 7805 IC to convert 12v to 5v
- Dustbin

This proposed system uses 12v battery power for the GSM module. Converting of 12v to 5v is done using 7805 IC for activation of all sensors. Arduino UNO board AT Mega 2560 uses a 9v battery. This block diagram reveals usage of 2IR sensors connected to the Arduino UNO through a motor drive IC L293D for the development of line following bot which tracks a white line on black surface or vice-versa. This system basically works like android mobile app controlled bot using Bluetooth mechanism. This system is connected to Arduino UNO board through the pin numbers 0(tx) and 1(rx). Whenever user gives the instruction as '0' the movement of the robot will stop. When the instruction is '1' then the robot moves in forward direction and '2' for reverse direction. The instruction '3' is for the movement to its left direction and '4' is for the movement to its right direction. Using all these directions, the robot can easily be accessible to the user towards reaching the desired destination. We are placing the dustbin on top of the robot for its movement. When the odour in dustbin reaches the maximum limit then its sensed by the ultrasonic sensor affixed to the top wall of the dustbin. This is intimated to the user through the

message using GSM module. Ultrasonic sensor is connected to Arduino UNO through the pin numbers 8 & 9. It also consists of gas sensor for sensing the stinking smell inside the dustbin. It is connected through the A0 pin of the Arduino UNO board. The IR sensor senses the obstacles while moving in the path according to the user's instructions and thereby preventing the robot from being damaged.

V. WORKING PRINCIPAL

The proposed robot consist of two IR sensor and one motor driver circuit L293D with 2 DC motor for left side wheel and right side wheel. The Arduino uno is the heart of the robot. Here we use ultrasonic sensor to detect the amount of garbage present in the dustbin. And gas sensor is used to sense the odour of the proposed system. The line following bot needs mechanical arrangement of the chassis. Let's assume a two wheel robotic vehicle with one castor wheel for front side. There are two IR sensors which are fixed on to the robot facing the earths surface. Working of line following robot is based on the IR sensor output.

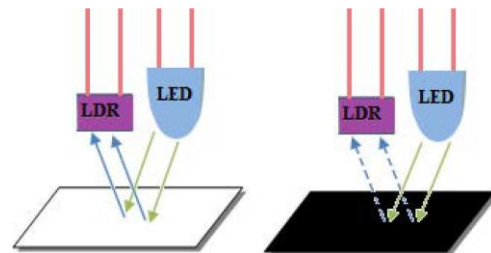

The principle behind the IR sensor is when the light hits the surface, only small amount of energy is absorbed and rest of the energy gets reflected. Surfaces of different kinds absorb and reflect light in different portions. Black will absorb more light when compare to white surface. The reflected light intensity is detected by the receiver as shown in fig. based on this we will get the output high and low

Here the robot reaches its destination by detecting the line drawn over the surface. The motion of the robot is based on the output of two IR sensors. When these two IR sensors are along path i.e. on the line, the robot moves in forward direction. If the left IR sensor is away from the line the robot travels towards right. Correspondingly, if right IR sensor moves away from the path the robot travels towards its left. Whenever robot gets deviated from its desired path it is recognized by the IR sensor. Whenever, the robot gets deviated from the white surface, IR rays starts reflecting and makes the output low. Thus based on the output of the IR sensors microcontroller indicates to change the motor direction[2]. Is as shown in table number 1

Sl.no	Left IR sensor output	Right IR sensor output	command	Left motor condition	Right motor condition
1	0	0	Stop	No rotation	No rotation
2	0	1	Rotate Left	No rotation	Rotate forward
3	1	0	Rotate Right	Rotate forward	No rotation
4	1	1	Go	Rotate forward	Rotate forward

Table 1: Different conditions for line following robot wheel movement

The ultrasonic sensor can detect the distance of any object and can also detect movement of it. It measures the distance in both CMSs and inches. The max distance that it can measure up to 233 cm with a accuracy of 3 centimetre. The ultrasonic sensor sends ultrasonic sound waves that bounce off an object ahead of it and then returns back and the time is calculated. This sensor is accurate only in detecting at flat surfaces – it is capable of detecting object with maximum angle of 15 degrees [8]. The communication link between Arduino board and Android based smart phone application can be attained through different mechanism. The Arduino can perform many complex actions, that are controlled through Android phone. Here we make use of Bluetooth communication to set up the communication between the Arduino and Android based smart phone. Virtually all Android based devices have Bluetooth communication module inbuilt in it. Based on the user instructions through mobile app robot is going to work. If garbage reaches threshold level in the dustbin odour is high in the dustbin, proposed system will send the message to the concerned person.

VI.PROPOSED SYSTEM FLOW CHART

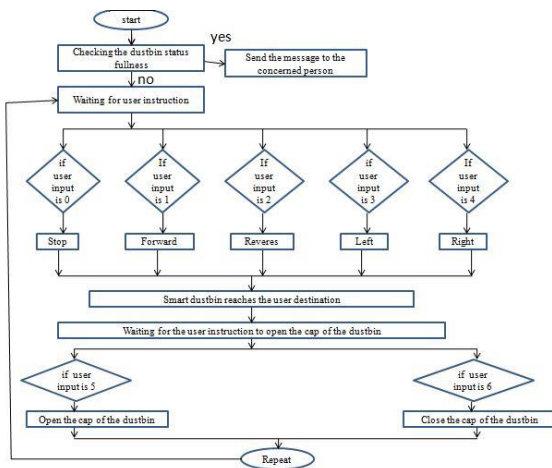

Fig2: Flow chart of the smart moving dustbin

When the system starts it's process firstly it checks the dustbin garbage level whether it reaches threshold level set by the user or garbage level reaches the 90% of the dustbin ,if the garbage reaches the threshold level, system will send the text message to the concerned person mobile by using

GSM module. If the garbage don't reaches the threshold level then the system will wait for the user instruction to further process. User will give the instruction through the android mobile app, which is installed by the user which is comfortable for arduino uno with Bluetooth accessibility. Based on the user instruction system will perform the assigned task. That is if user gives '0' command to the arduino uno then system will stop rotating, and if user gives '1' then system will move forward direction and it follows the assigned line, which is block line on the white surface or vice versa. For 2 it will perform the reverse direction and follows the line. User will use '3' and '4' command to rotate the system for left and right direction. Based on the above techniques the line following robot will reaches the user destination. Once it reaches the user destination, system will detect the person and open the cap of the dustbin. And automatically close when he moves away from the dustbin.

VII.VII. RESULTS

1).Initial condition of line following robot with pre-defined path.

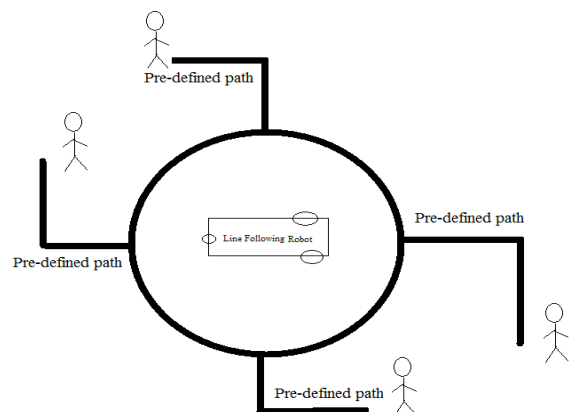

Fig.3:initial condition of a line following robot

2) when the Dustbin is full it will send a message to the concerned person as shown in fig.

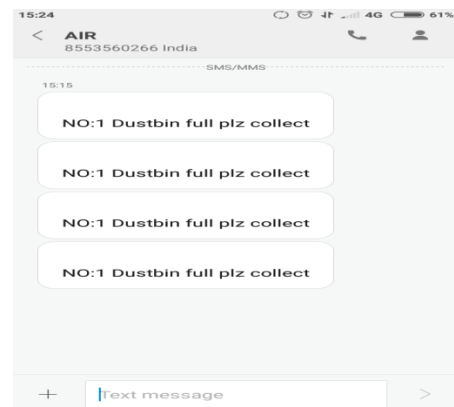

Fig4. Message received screenshot when Dustbin is full

3) When the odour is high inside the dustbin concerned person will get a message is as shown in fig.



Fig5. Message received screenshot when odour is more

VIII.CONCLUSION

The above paper is implemented using Arduino Uno and GSM module with operating voltage of 5v and 12v. based on the android mobile app installed by the user, Arduino will receive the command by the user. Based on the command it is going to perform. This paper will help the physically challenged person, aged people and it will also help us to maintain the clean home surrounding. So that it will fulfil the swachh bharath mission.

REFERENCES

1. aamir attar, 2aadil ansari, 3abhishek desai, 4shahid khan, 5dipashri sonawale (2017) "line follower and obstacle avoidance bot using arduino" International Journal of Advanced Computational Engineering and Networking, ISSN: 2320-2106, Volume-5, Issue-4, April.-2017
2. Kazi Mahmud Hasan, Abdullah-AI-Nahid, Abdullah Al Mamun (2012)"Implementation Of Autonomous Line Follower Robot" IEEE/OSA/IAPR International Conference on Informatics, Electronics & Vision 978-1-4673-1154-0112/\$31.00 ©20 12 IEEE.
3. Deepak Punetha, Neeraj Kumar, Vartika Mehta (2013) "Development and Applications of Line Following Robot Based Health Care Management System" International Journal of Advanced Research in Computer Engineering & Technology (IJARCET) Volume 2, Issue 8, August 2013 pp ISSN: 2278 – 132
4. Anil Kumar C.S Dr.Venkata Siva Reddy.R(2017) "Smart Solid and Liquid Waste Management Using IoT" CiiT International Journal of Programmable Device Circuits and Systems, Vol 10, No 1, January 2018 ISSN: 0974 – 9624
5. Gopal Kirshna Shyam1,Sunilkumar S. Manvi2,Priyanka Bharti3 (2017)"Smart Waste Management using Internet-of-Things (IoT)" 2017 Second International Conference On Computing and Communications Technologies(ICCCT'17)
6. Bharadwaj B, M Kumudha, Gowri Chandra N " Chaithra G(2017) "automation of smart waste management using iot to support swachh bharat abhiyan a practical approach" 2017 Second International Conference On Computing and Communications Technologies(ICCCT'17)
7. Jan Nádvořník, Pavel Smutný (2014)"Remote Control Robot Using Android Mobile Device" 2014 15th International Carpathian Control Conference (ICCC) 374, 978-1-4799-3528-4/14/\$31.00 ©2014 IEEE
8. FRISCHKNECHT, Claudia & OTHER, Thomas. LEGO Mindstorms NXT, Next Generation. [online]. Swiss Federal Institute of Technology Zurich, 2006. [cit. 2014-01-18] Available: http://www.tik.ee.ethz.ch/mindstorms/sa_nxt/index.php?page=tests_us

Author's profile



Anil Kumar C S: Has 2 years of teaching experience and I have graduated from Institution of engineers India" and done my master in VLSI and embedded system, my area of research are cyber physical system, embedded system, and Analog VLSI Design. I am member of institution of Engineers. I have presented papers in various national and international conference and journals.



Suhas g : a present ug scholar in ECE at Reva university and completed his pre university at "St joseph's pre university" Bangalore. Working on different fields such as IOT and machine learning. And done many works related to IOT.



Sushma s: a present ug scholar in ECE at Reva university and completed her pre university at "Alva's college" Moodbidri. She have been working on project like a smart agriculture using WSN and cloud computing. And have done many projects on IOT.