

Compensation of Power Fluctuations in PV System through Energy Storage System



Kritika Vivek Narkhede

Abstract—The variations produced by the change in cloud cover can cause rapid fluctuations in power generated by photovoltaic system. Thus, energy storage system are necessary in order to smooth power fluctuations. The main objective of this paper is to design photovoltaic system to regulate the fluctuations through energy storage system. Thus we have proposed a system in which we use dc-dc converter for MPPT application, TL494 IC generate the pulse for charging the battery as well as to regulate the fluctuations.

Keywords—DC-DC converter, TL494

I. INTRODUCTION

In 21st century, the major climatic issues or the awareness of the world is to how to increase the demand for clean and renewable energy [1]. The world photovoltaic capacity has grown at an approximate rate of 49% per year since 2003. The major systems are grid connected and provide the electricity to power system around the world. [2]. Grid-connected photovoltaic system had been low prior compared to the conventional energy sources. The amount of fluctuations in public grid has previously been low enough to be absorb and smooth the inertia within the power system. The amount of grid-connected photovoltaic system had increased from past years and hence have concerns on effect of fluctuations on the power system. Photovoltaic system offers environmental friendly source of power generation for generating electricity due to which the fuel is sunshine, clean and pollution free our surroundings. Solar panel which consists of solar cells which are connected in series or in parallel in an array form and is a fundamental energy conversion component in the photovoltaic system. The system can be used in aerospace industries, electric vehicles, grid connected system equipment etc.

The power delivered from the PV panel depends on external factors such as isolation levels, temperature, and load conditions. The photovoltaic fluctuation can be compensated and the requirements are fulfilled by Energy Storage System. The main areas of interest are the capacity and power required as well as cycling induced lifetime considerations. Power balance between generation and demand for power to local load at regulated voltage can be maintain by photovoltaic system. The voltage can be regulated by reducing the transient that may occur in photovoltaic system due to variation in supply and the load demands.

Revised Manuscript Received on October 30, 2019.

* Correspondence Author

Kritika Vivek Narkhede*, Department, AISSMS's Institute of Information Technology, Pune, Maharashtra, India.

© The Authors. Published by Blue Eyes Intelligence Engineering and Sciences Publication (BEIESP). This is an open access article under the CC-BY-NC-ND license <http://creativecommons.org/licenses/by-nc-nd/4.0/>

For achieving the fast dynamic performance under supply and the load fluctuations and to store the electrical energy through battery when there is an surplus amount is available and fulfil the demand of load when it required.

The Photovoltaic system uses solar cell connected in an array to convert the solar energy into electrical energy. The photovoltaic systems are similar to other electrical power generating system, the only difference is the equipment used in the photovoltaic system from the conventional electro-mechanical generating systems. Also, In photovoltaic system the principle of operation and the method of interfacing the system with the other electrical system remains same as of other conventional electro-mechanical system. Photovoltaic systems are operated in three different modes known as the standalone mode, the grid-connected mode, and the hybrid mode. As we know, now-a-days most of the photovoltaic systems are connected with the utility grid but whereas in remote areas where the utility supply is not available there standalone photovoltaic system are used. Solar power is the only source of power for the standalone photovoltaic system. As we know the electrical energy which is produced by the photovoltaic panels cannot be constantly used. As the demand of the load changes according to the time interval it may or may not be equal to the solar panel capacity, therefore this issue can be resolved using battery storage banks. This battery storage banks or storage device plays an important role in the standalone photovoltaic system to maintain the power balance between load demand and the photovoltaic generation system. The hybrid photovoltaic system is a system in which the the hybrid power is the complete electrical power supply system which can be arranged to meet the wide range of power demands.

The hybrid photovoltaic system has basic three elements in the system they are – the power sources, the battery, and the power management center. The hybrid power sources consists of wind turbines, diesel engine generators, thermoelectric generators and solar photovoltaic system. A separate operation by compensating the difference between power production and for the load demand allows the battery. In hybrid photovoltaic system a power management center is developed which regulates the power from the sources, classifying the loads to maintain the use of power and protect the the battery banks from the over dissipation of power.

In grid connected photovoltaic systems battery storage banks or storage device are not the critical element, but sometimes it is used to reduced the photovoltaic power fluctuations, perform peak shaving operation and supply power at emergency. [3, 4].

Compensation of Power Fluctuations in PV System through Energy Storage System

In grid connected photovoltaic system, to maintain the voltage li-ion batteries are used as backup power supply, active and reactive power compensation to maintain the frequency. Hence the system will maintain the balance between supply of active and reactive power and demand at any point of time.[5] Various control technique are used they are the MPPT control, and voltage-frequency [6]. Standalone PV system also uses same control techniques. In standalone PV system the main component are photovoltaic panel module, battery system and local loads for modelling and controlling system.

If the output power of the PV is less than or equal to the output power of the system and the storage units are deeply discharged, then whole system is shut down and there will be no power flow . Secondly If the output power of the PV is less than or equal to the output power of the system and the storage units are not deeply discharged ($V_s > V_{s_min}$) or $P_{pv} > P_o$ with the storage units not fully charged ($V_s < V_{s_max}$), the push pull dc-dc converter will work in MPPT mode and the dc-dc converter will regulate the DC bus voltage to maintain the power flow balance of the system. If the PV arrays can not provide enough power to load, the storage units will be discharged to provide the power deficit. If the PV arrays generate more power than load consumes, the superfluous energy will charge the storage units.

II. SYSTEM CONFIGURATION

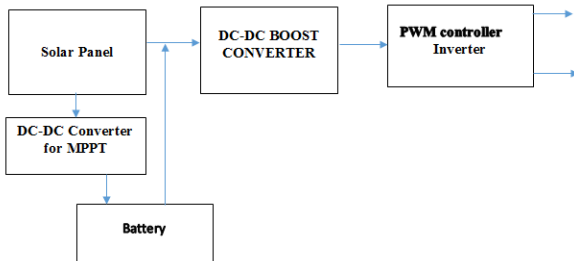

Figure 1 Block diagram

In this proposed system when the variations in irradiance produced during cloud cover which causes rapid fluctuations in power generated by photovoltaic systems. This fluctuations adversely affect the system reliability. Thus to reduce the fluctuations energy storage system is used.

A. DC-DC converter for maximum power tracking

The maximum power point tracking system uses different types of method such as control circuit or logic to obtain maximum power point from the photovoltaic panel so that the converter control circuit to extract maximum power all the time. The maximum power tracking track the maximum power point from the photovoltaic panel so that more and more power can utilized. Maximum power point tracker system consists of DC/DC converter between photovoltaic panel and the load. There are different types of DC/DC converter which are based on isolated and non-isolated converter. Maximum power point tracking system uses mainly two loops one to maintain the constant switching frequency and other to maintain the tracking algorithm. Pulse width modulation control technique require for the system for efficient working of the system. In this proposed system TL494 IC is used for push pull isolated converters to

control the duty cycle of PWM for small change in voltage level from DTCON pin.

In this paper a Push pull converter based on TL494 control circuit is used . In this proposed system , TL494 IC is used for pwm generation for push pull high frequency converter.. This converter system is also used for battery charging . When there is surplus supply from photovoltaic system and is not required to the load then converter charges the battery of the system.

B. DC-DC Boost converter

In this proposed system the boost converter is designed using TL494 IC. when power is to supplied to the load this converter designed is used for supply the load

III HARDWARE IMPLEMENTATION AND DESIGN

In this system the solar panel voltage 13.4v is stepdown to 14v for charging the battery when load does not requires . When the fluctuation occurs in the system due to clouding cover or voltage fluctuations and the photovoltaic panel is not able to supply the load then the battery system is used for continuously supply of the system.

A. Components

The components required for the hardware design are 4 TL494IC, 2 ferrite core transformer, 8 power MOSFETs IR3205, transistors , diodes, resistors, IR2110.

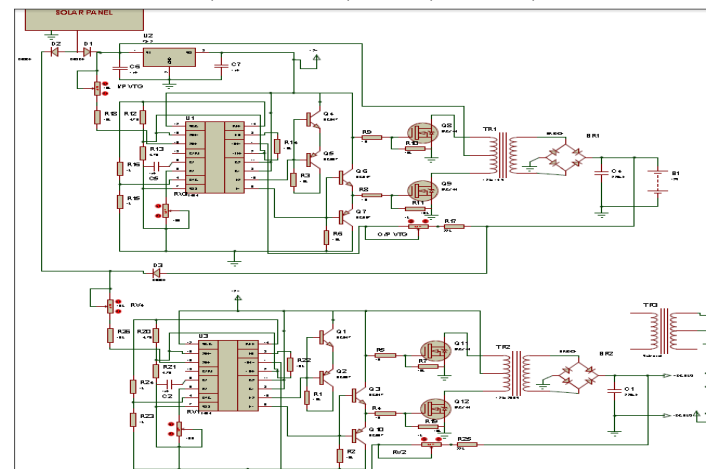

Figure 2 Hardware design of dc-dc converter for MPPT application and boost converter

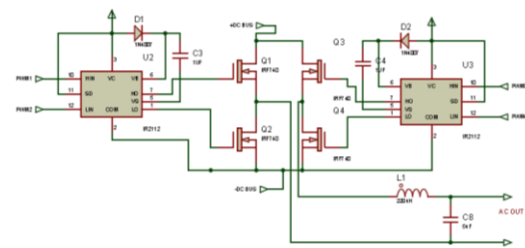

Figure 2 Hardware design of inverter

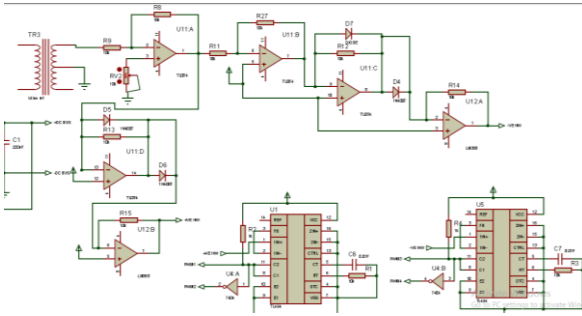

Figure 3 design for drive the the inverter circuit

B. Designing of push pull converters

- Ferrite Core transformer Design

For designing high frequency push pull converter in solar panel side using ferrite core center tap transformer. The converter of proposed system is a ferrite core center tap transformer, considering electrical parameters shown in table 1 for calculating turns of ferrite core transformer for designing dc/dc converter.

Table1 electrical parameters considered while design of dc/dc converter

Minimum input voltage $V_{I(min)}$	12Volts
Maximum input voltage $V_{I(max)}$	14.5Volts
Nominal voltage $V_{I(nom)}$	13.5Volts
Switching frequency	20KHz

The primary and secondary turns are calculated

$$N_p = \frac{V_I (nom) \cdot 10.8}{4 \cdot f \cdot B_m \cdot A}$$

$$N_p = 15$$

Where,

N_p = Primary turns;

N_s = Secondary turns

$V_{I(nom)}$ = Input voltage (nominal)

f = Switching frequency

B_m = maximum flux density (gauss)

A = effective cross sectional area

$A=0.76$ for ETD29.

Now, Voltage ratio= (secondary: primary)

$$\text{Voltage ratio} = 1.23$$

turns ratio (secondary: primary) = voltage ratio.

So, Turns ratio, $N = 1.23$

$$N_p = 15$$

$$N_s = N * N_p = 1.23 * 15$$

$$N_s = 19 \text{ turns approx.}$$

C. Transformer design of boost converter side

- Ferrite core transformer

For designing high frequency push pull converter, in this proposed system we design ferrite core center tap transformer. The converter of proposed system is a ferrite core center tap transformer, considering electrical

parameters shown in table 1 for calculating turns of ferrite core transformer for designing dc/dc converter .

Table2 electrical parameters considered while design of dc/dc converter

Minimum input voltage $V_{I(min)}$	12Volts
Maximum input voltage $V_{I(max)}$	20Volts
Nominal voltage $V_{I(nom)}$	13.5Volts
Switching frequency	20KHz
Output voltage V_{out}	250volts

The number of primary and secondary turns are calculated:

$$N_p = \frac{V_{I(nom)} \cdot 10.8}{4 \cdot f \cdot B_m \cdot A}$$

$$N_p = 12 \text{ turns (approx.)}$$

Where,

N_p = Primary turns ;

N_s = Secondary turns

$V_{I(nom)}$ = Input voltage (nominal).

f = Switching frequency (hertz)

B_m = maximum flux density (gauss)

A = Effective Cross-Sectional Area .

=0.76 for ETD34.

Now, the Voltage ratio=(secondary: primary)

$$\text{Voltage ratio} = 21.25$$

Turns ratio (secondary: primary) = voltage ratio.

So, turns ratio, $N = 21.25$

$$N_p = 12$$

$$N_s = N * N_p = 21.25 * 12.$$

$$N_s = 255 \text{ turns approx.}$$

D. PWM Circuit and Feedback Control circuit

Control IC TL494 is used for generation of PWM signal and feedback control signal. TL494 is a complete Pulse width modulation power control circuitry Figure. 2 show a practical push pull converter with PV module. The power circuit consists of a push-pull converter, TL494, and feedback components for the proposed circuit. TL494 is designed for power-supply control, this IC offers the flexibility to alter the power-supply control circuit to a particular application. TL494 has two error amplifiers which are connected to solar panel and then the pwm pulses are generated and supplied to converter and then to transformer and the feedback of TL494 is connected to push pull converter .

This system also used for charging of the battery when the photovoltaic system is not used for supply of load or surplus amount of power is present in photovoltaic panel. Now if the fluctuations occur in the photovoltaic panels then supply to the load will be irregular. For supplying the load properly the battery will supply power to the load through the TL494 and the boost converter.

Compensation of Power Fluctuations in PV System through Energy Storage System

Figure 3 show the inverter design of the system .the pwm pulses which is generated by the TL494 is supplied to the inverter system .the output of the system is the constant sinusoidal pulse width modulation pulses this shows that the fluctuations of photovoltaic system is reduced through the energy storage system.

IV HARDWARE AND RESULTS

Figure 4 shows the prototype model for the system.

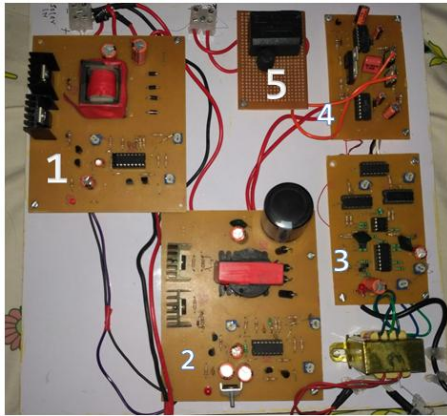

Figure 4 Hardware

1. Indicate the dc dc converter for MPPT application and also used for charging the battery when excess amount of energy is available.
2. Indicates the dc dc boost converter. Figure 4.3 shows the connection diagram
3. Indicates the firing circuit for the power mosfet of the inverter
4. Indicates the inverter circuits Figure 4.5 shows the connection diagram
5. Indicates the ac output filter for filtering the signals

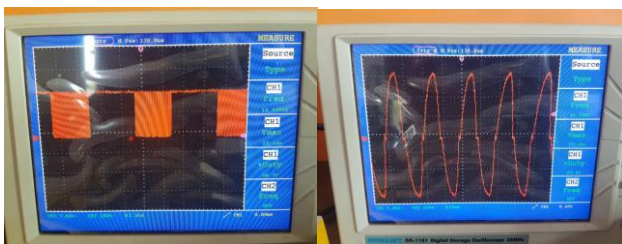

Figure 5 output waveform

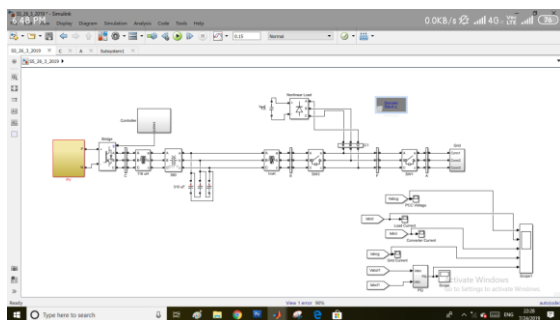

Figure 6 MATLAB Simulink

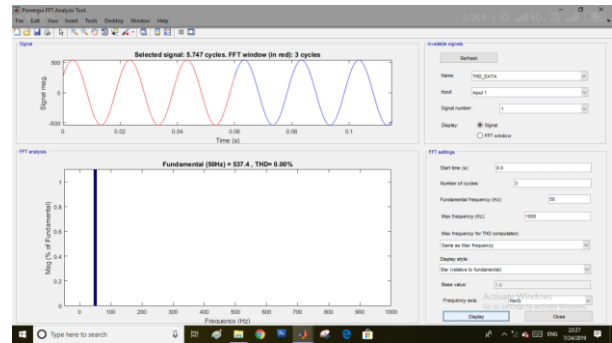

Figure 7 output

VI CONCLUSION

From above system , the energy storage system can be used so that the fluctuations in the photovoltaic system due to the cloud cover or due to the load demand. In this paper, when there is fluctuations in supply from the solar due to weather or due to panel then the battery system is will provide continuous supply. Also when there is extra supply from the panel is present then the battery will also be charged simultaneously. Therefore the energy is stored can be used .

REFERENCES

1. H. Mahmood, D. Michaelson, and J.Jiang "A power management strategy for PV/Battery hybrids systems in islanded micro grids" (2014).
2. H. Mahmood, D. Michaelson, and J. Jiang "Control strategy for standalone PV/Battery hybrid system" (2012).
3. W. A. Omran, M. Kazerani, and M. M. A. Salama "Investigation of methods for reduction of power fluctuations generated from large Grid-connected photovoltaic system" (2011).
4. H. Fakhm, D. LU, and B. Francois "Power control design of a battery charger in a hybrid active PV generator for load following application" (2011).
5. R. Bhatt and B. Chowdhary "Grid frequency and voltage support using PV system with energy storage" (2011).
6. S. Adhikari and L. Fangxing "Coordinated V-f and P-Q control of solar photovoltaic generators with MPPT and Battery storage in Microgrid" (2014).
7. R.-J. Wai, W.-H. Wang and C.-Y.Lin "High performance standalone photovoltaic generation system" (2008).
8. H.-L.Tsai, Ci-S.Tu and Yi-J.Su "Development of generalized photovoltaic model using MATLAB/SIMULINK" (2008).
9. J.B. Copetti and F. Chenlo "A general battery model for PV system simulation" (1994).
10. O. Tremblay and L.-A. Dessaint "Experimental validation of a battery dynamic model for EV applications" (2009).
11. J. M. Carrasco, L. G. Franquelo, J. T. Bialasiewicz, E. Galván, R. C. Portillo Guisado, Ma. Á. Martiagute;n Prats, J. I. León, and N. Moreno-Alfonso "Power-electronic systems for the grid integration of renewable energy sources" (2006).
12. H. S.-H. Chung, K. K. Tse, S. Y. R. Hui, C. M. Mok, and M. T. Ho "A novel maximum power point tracking technique for solar panels using aSEPIC or Cuk converter" (2003).
13. A. I. Bratcu, I. Bratcu, I. Munteanu, S. Bacha, D. Picault, and B.Raison "Cascaded DC-DC converter photovoltaic system : power optimization techniques" (2011).
14. IEEE Trans. T. Esram and P.L. Chapmann "Comparison of photovoltaic array maximum power tracking techniques" (2007).
15. V. Salas, E. Olias, A. Barrado and A. Lazaro "Review of the maximum power point tracking algorithm for standalone photovoltaic system" (2006).

16. K.H. Hussein, I. Muta, T. Hoshino, and M. Osakada “Maximum photovoltaic power tracking: An algorithm for rapidly changing atmospheric conditions” (1995)
17. F. Salem, M.S. Adel Moteleb, and H.T. Dorrah “An enhanced fuzzy PI controller applied to the MPPT problem” (2005).

AUTHORS PROFILE



Kritika Vivek Narkhede , Power Electronics and Drives,(Electrical Department), AISSMS's Institute of Information Technology, Pune, Maharashtra, India.
E-mail:- kritikanarkhede95@gmail.com.