

SEPIC Rectifier with Voltage Doubler Characteristics Based Wind Energy System for High Power Battery Storage Applications

Elangovan S, Kamatchi Kannan V, Senthil Raja K, Bhuvanewari S

Abstract:--- Now a day's electric power is generated by using renewable resources. Energy produced by solar and wind are commonly used renewable resources. The objective is to use the SEPIC rectifier with voltage-doubler characteristics used in high power battery storage applications. This SEPIC rectifier converts AC voltage generated from an AC generator using wind energy into DC voltage required for high power battery storage applications. The proposed SEPIC rectifier with voltage-doubler characteristics is used for multiplying the voltage by factor two.

Keywords: SEPIC converter, Voltage doubler, Wind Energy

I. INTRODUCTION

Electricity demand rises gradually due to industrial development and growth. This demand can be solved by using renewable energy sources. Solar energy and battery is used for this purpose. But a problem arises when the sun light is not available. In order to reduce these types of situation, the solution is to maintain the energy stored in the battery. It is achieved by using another renewable energy source called as wind energy. Electrical power is produced by using wind energy and rectified into DC. This rectified voltage is used to charge the battery for high power applications.

Wind driven generator technology is achieved to generate electrical energy to charge the battery of automobile industry [1]. The Pulse Width Modulation (PWM) technology is used. The Permanent Magnet Synchronous Generator is operated by the movement of air at a speed of 15 to 40 km/hr. It reduces the use of gear box and its efficiency is improved. The three phase full bridge converter is used for rectifying sinusoidal voltage to direct voltage and this voltage is applied to boost converter to charge the battery.

A family of single phase voltage doubler boost converters which uses Pulse Width Modulation PWM technology is explained in [2]. Three characteristics of switching patterns are analysed by observing the switching stages of single phase boost converters. They are unipolar, bipolar and phase-adjusted unipolar PWM. Voltage doubler circuits are used to produce higher output voltages with the lowest distortion.

A SEPIC rectifier is used for applications that needs the correction of power factor [3]. This type of converter has reduced the number of components used which reduces on-state losses. Power factor correction requires voltage and current loop. This converter reduced the complexity of control circuit and it does not need current loop for discontinuous conduction mode [4]. SEPIC converter is used as Pre-regulator for correcting the value of power factor [5]. The working principle of this converter is analysed in discontinuous conduction mode as Pre-regulator [6].

During travelling, low power electronic devices are charged with the help of wind energy [7]. A DC generator is utilized for generating DC voltage which is given to SEPIC rectifier. When the vehicle speed is greater than 40km/hr, electronic devices are charged from SEPIC rectifier. It is used as an alternative source for charging the low power electronic devices while roaming in a vehicle.

In order to serve the battery applications which need higher power, the voltage-doubler Single Ended Primary Inductor Converter (SEPIC) rectifier is used. SEPIC rectifier is used in applications which needs higher voltage level. In section II, working of the SEPIC converter voltage doubler has been described. In section III, simulation results of SEPIC converter voltage doubler has been explained.

II. SEPIC RECTIFIER VOLTAGE DOUBLER

In the proposed system given in figure 1, the AC output of the wind turbine is directly fed into the voltage doubler SEPIC converter [8]. It rectifies the AC input into DC output. The DC output of the voltage doubler SEPIC converter is twice that of the AC input voltage. Hence the proposed system can be utilized in applications that needs high power. The voltage regulator regulates the voltage at a particular value. This could be utilized as an alternative source used in high power battery.

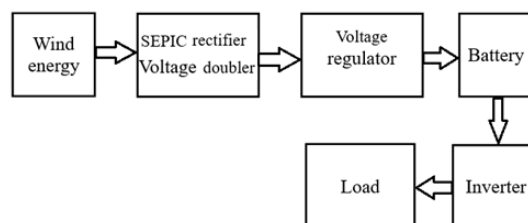

Figure 1. The proposed system.

Revised Manuscript Received on December 22, 2018.

Elangovan S, Assistant Professor, Department of Electrical and Electronics engineering, Bannari Amman Institute of Technology, Sathyamangalam, Tamil Nadu, India, (elangovans@bitsathy.ac.in)

Kamatchi Kannan V, Associate Professor, Department of Electrical and Electronics engineering, Bannari Amman Institute of Technology, Sathyamangalam, Tamil Nadu, India, (kamatchikannan@bitsathy.ac.in)

Senthil Raja K, Assistant Professor, Department of Electrical and Electronics engineering, Bannari Amman Institute of Technology, Sathyamangalam, Tamil Nadu, India, (senthilrajak@bitsathy.ac.in)

Bhuvanewari S, Assistant Professor, Department of Electrical and Electronics engineering, Bannari Amman Institute of Technology, Sathyamangalam, Tamil Nadu, India, (bhuvanewaris@bitsathy.ac.in)

SEPIC Rectifier with Voltage Doubler Characteristics Based Wind Energy System for High Power Battery Storage Applications

The SEPIC rectifier voltage-doubler is presented in figure 2[9]. It consists of two SEPIC rectifier which operate as half-wave rectifier. One SEPIC rectifier operates in positive cycle and another one in negative cycle. So output voltage of proposed converter is multiplied by the factor two. This converter has the following elements.

- C_{i1}, C_{i2} – Input capacitors
- C_{o1}, C_{o2} – Output capacitors
- L_i – Inductor at input side
- L_{o1}, L_{o2} – Inductors at output side
- D_{o1}, D_{o2} – Diodes at output side
- R_o – Load resistor
- S – MOSFET switch
- $D1, D2, D3, D4$ – Diodes

There are six stages in the converter operation. Three stages constitute positive half cycle and remaining three stages constitute negative half cycle. In steady state, the voltages across C_{i1}, C_{i2}, C_{o1} and C_{o2} are, respectively, $V_m, V_m, V_o/2$ and $V_o/2$, where V_m is the maximum value of the source voltage and V_o is the output voltage. In first stage of converter operation, MOSFET switch S is closed and diodes D_{o1}, D_{o2} are reverse biased. The currents flowing through the L_i and L_{o1} starts to increase and energy is stored. The capacitors C_{o1} and C_{o2} supplies the current through the load resistor R_o .

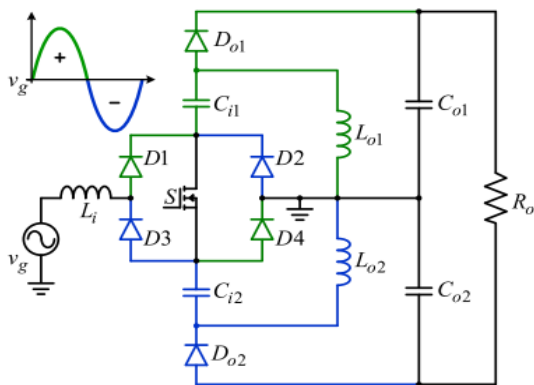

Figure 2. SEPIC Rectifier Voltage Doubler [9].

In the second stage of converter operation, the MOSFET switch S is opened which forward biases the diode D_{o1} and reverse biases the diode D_{o2} . The currents flowing through the L_i and L_{o1} starts to decrease and the energy stored by the inductors L_i and L_{o1} in the first stage is moved to the capacitors C_{i1}, C_{o1} and the load resistor R_o . When $I_{L_{i\min}}$ is equal to $I_{L_{o\min}}$ with opposite polarity, third stage of converter operation takes place which is shown in figure 4. In this stage the current in the diode D_{o1} is zero and rectifier operates in discontinuous mode. The C_{o1} and C_{o2} capacitors supplies the current through load resistor R_o .

In the fourth stage of converter operation shown in figure 5, the MOSFET switch S is closed which forward biases the diodes D_{o1}, D_{o2} . The currents flowing through the L_i and L_{o2} starts to increase and energy is stored. The capacitors C_{o1} and C_{o2} supplies the current in the load resistor R_o . In fifth stage of converter operation shown in figure 6, the MOSFET switch S is opened which forward biases the diode D_{o1} and reverse biases the diode D_{o2} . The currents

flowing through the L_i and L_{o2} starts to decrease and the energy stored by the inductors L_i and L_{o2} in the fourth stage is moved to the capacitors C_{i1}, C_{o1} and the load resistor R_o .

When $I_{L_{i\min}}$ is equal to $I_{L_{o\min}}$ with opposite polarity, sixth stage of converter operation takes place which is shown in figure 7. In this stage the current flowing through the diode D_{o1} is zero and the rectifier is in discontinuous conduction mode of operation. The C_{o1} and C_{o2} capacitors supply the current through load resistor R_o .

III. SIMULATION RESULTS

The simulation circuit diagram is shown in figure 3. Simulation results of SEPIC Rectifier Voltage Doubler have been obtained by using MATLAB/ SIMULINK. It consists of wind generation unit and SEPIC rectifier voltage doubler circuit. Wind speed is assumed to be 12m/s. The output voltage of wind generation unit is given to the input of the SEPIC rectifier voltage doubler circuit which multiplies the voltage by the factor two.

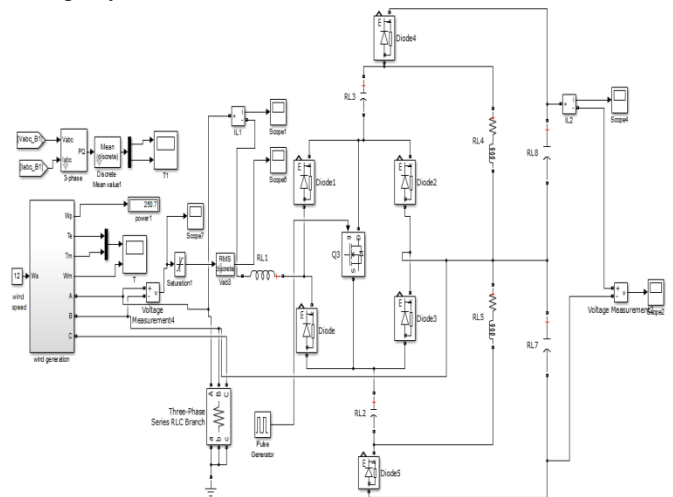

Figure 3. Simulation circuit diagram

Figure 4 and 5 show the capacitor voltage waveform and input voltage of SEPIC rectifier voltage doubler circuit. The input voltage of SEPIC Rectifier Voltage Doubler is 60 V.

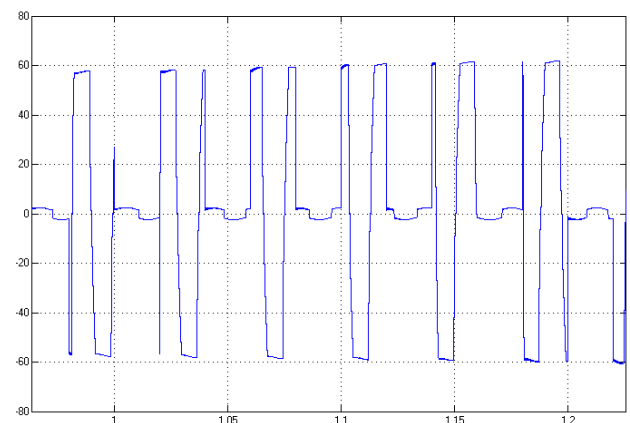

Figure 4. Capacitor Voltage Waveform

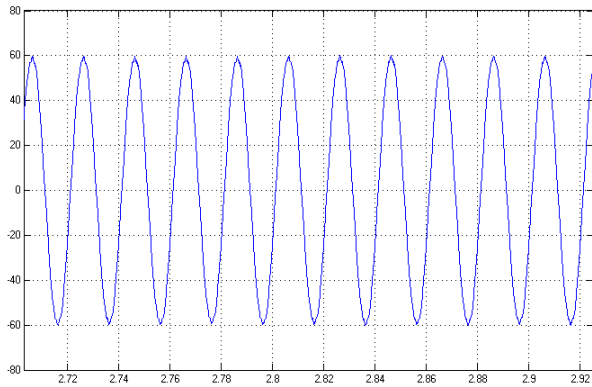

Figure 5. Input Voltage of SEPIC Rectifier

Figure 6 and 7 show the output DC voltage of SEPIC rectifier voltage doubler circuit. The input AC voltage 60 V is converted into 120 V DC by using this voltage doubler rectifier circuit. The DC output of the SEPIC rectifier voltage doubler is twice that of the AC input voltage. Hence the proposed system can be utilized in battery storage applications.

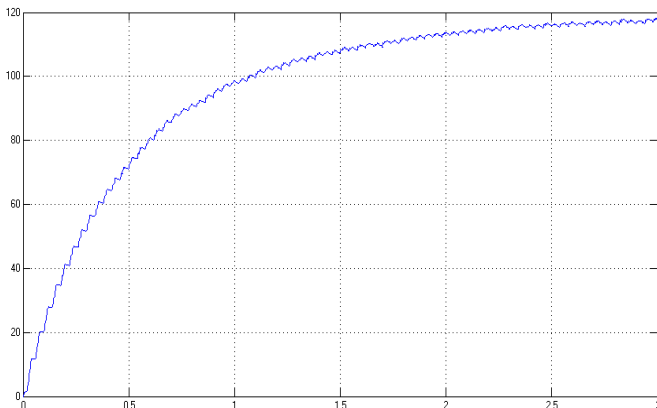

Figure 6. Output voltage of SEPIC Rectifier Voltage Doubler.

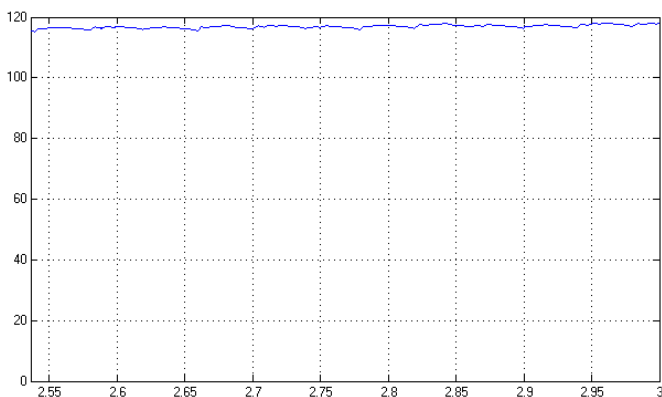

Figure 7. Output DC voltage of SEPIC Rectifier Voltage Doubler.

IV. CONCLUSION

In this paper, SEPIC rectifier with voltage-doubler characteristics have been used to double the voltage for battery storage applications. Simulation results of input and output voltage of SEPIC Rectifier Voltage Doubler have been obtained by using MATLAB/ SIMULINK. The DC output of the SEPIC converter voltage doubler is twice that

of the AC input voltage. Hence the proposed system can be used in high power battery storage applications.

REFERENCES

1. S.N. Singh, Sumit Kumar Jha, Sudhir Kumar Sinha, "Wind driven mobile charging of automobile battery" International Journal of Engineering Science and Technology (IJEST) : (3):1:68-74, 2011.
2. J. C. Salmon, "Circuit topologies for single-phase voltage-doubler boost rectifiers", IEEE Trans. on Power Electronics, vol. 8, no. 4, pp. 521 - 529, October, 1993.
3. E. H. Ismail, "Bridgeless SEPIC rectifier with unity power factor and reduced conduction losses", IEEE Trans. on Industrial Electronics, vol.56, no. 4, pp. 1147 – 1157, April, 2009.
4. A. J. Sabzali, E. H. Ismail, M. A. Al-Saffar, A. A. Fardoun, "New bridgeless DCM Sepic and Cuk PFC rectifiers with low conduction and switching losses", IEEE Trans. on Industrial Electronics, vol. 58, no. 9, pp. 4153 – 4160, September, 2011.
5. D. S. L. Simonetti, J. Sebastian, F. S. dos Reis, J. Uceda, "Design criteria for SEPIC and Cuk converters as power factor preregulators in discontinuous conduction mode", International Conference on Industrial Electronics, Control, Instrumentation, and Automation, vol. 1, pp. 283 – 288, 1992.
6. D. S. L. Simonetti, J. Sebastian, J. Uceda, "The discontinuous conduction mode Sepic and Cuk power factor preregulators: analysis and design", IEEE Trans. on Industrial Electronics, vol. 44, no. 5, pp. 630 – 637, October, 1997.
7. Saikumar. P, ThamaraiKannan. D, Yuvaraj. G, Yuvaraj. C., "Wind Energy Based Mobile Battery Charging and Battery Applications" International Journal for Research and Development in Engineering (IJRDE), pp. 006 – 011, 2014.
8. Singh, B. N. Singh, A. Chandra, K. Al-Haddad, A. Pandey, D. P. Kothari, "A review of single-phase improved power quality AC-DC converters", IEEE Trans. on Industrial Electronics, vol. 50, no. 5, pp. 962 – 981, October, 2003.
9. Paulo Junior Silva Costa Federal, Carlos Henrique Illa Font Federal, Telles Brunelli Lazzarin Federal "Single-Phase Voltage-Doubler SEPIC Rectifier with High Power factor", IEEE 25th International Symposium on Industrial Electronics (ISIE), 2016.