

# A Novel Reconfiguration of Islanded Microgrid with RES and Energy Storage System

Kosuri Sravani, I Solomon Raju

**Abstract:** This paper proposes an elective procedure to control the produced power inside a disengaged air conditioning microgrid with appropriated RES. The suggestion is to control the terminal voltage of the present battery banks underneath or ascend to its most noteworthy reasonable regard. This is done by compelling the proportion of force that each imperativeness source can create at each minute. The microgrid repeat is used to depict the state of charge of the battery bank and measure to the converters' control systems how much power they need or can make to keep up leveled out the internal power equality of the microgrid. The control of the battery banks' terminal voltage construes by suggestion the control of their SOC.

**Index Terms:** Battery banks, isolated microgrids, parallel inverters, power control, renewable energy sources (RESs), state of charge (SOC)

## I. INTRODUCTION

Micro grids are turning into famous of assignment structures because she be able enhance the monitoring quality or reliability on control resources or limit the environmental impact. Smaller scale lattice act be capable stay arranged in twain modes: grid connected or islanded modes. When all is said in done, smaller scale lattices are involved about conveyed vitality sources (DERs) comprehensive of inexhaustible power sources, appropriated power tankage frameworks (ESSs), or halfway hundreds [1–3]. In any case, the use on sustainable power sources, for example, breeze then photograph voltaic control of smaller scale networks thought processes checking accept circumstances for what they are forms due in impersonation of vulnerabilities among their observing yields. These versions need to stay diminished to forgather control quality prerequisites [4,5]. This order centers about adapting to the issues as are included by methods for air control. To remunerate as a result of changes into breeze control, different ESSs have been executed between miniaturized scale matrices. Present moment ESSs, for example, much superconducting attractive vitality stockpiling (SMES) structures [6], electrical twofold layer capacitors (EDLCs) [7], at that point flywheel vitality stockpiling frameworks (FESSs) as like pleasantly as much long haul ESSs sure as like battery quality tankage frameworks (BESSs) [8-9] are used after smaller scale lattice control. ESSs perform also stay back after cutoff the standard coast at factor about continuous merger among the

framework associated energy to be specific appropriately in particular as per change the recurrence and voltage about a smaller scale lattice inside the islanded mode.

Among this ESSs, BESSs have been executed broadly due as per their flexibility, extreme quality thickness, and proficiency. In addition, their charge has diminished in light of the fact that their execution or breath has expanded. Practically speaking, BESSs along unreasonable generally speaking execution, for example, much spotless and rapidly solid answer all through charging then releasing are required for Microgrid control. This general execution relies upon the administration by and large execution concerning the legislature electronic converter. Proportional-integral (PI) control is a realistic yet popular control method because BESS monitoring systems. However, PI rule may exhibit unsatisfactory consequences because nonlinear or discontinuous systems [10]. When proper applied, these new, allotted technology gadgets (DG) offer great advantage in conformity with the grid then in imitation of cease users. However, merging DGs between the regular grid is no longer barring empirical challenges. The typical electrical grid was now not designed for power generation sources dispensed close to the ends concerning the T&D grid. The successful integration over DG government sources requires the single-direction grid structure about the previous transit after a smarter then greater agile bi-directional grid [11]. As DGs continue after acquire drawing among the electric market, moment pondering yet ongoing procedures round power age, dividing awful want continue after rise. One over the an expanding number of regular strategies since blending DGs into the huge electric network is another bend over an antiquated electrical engineering perceived so the Microgrid. Small scale matrices are zones about the framework so much do work as like area on the bigger large scale matrix at that point work self-rulingly as like an independent framework. The miniaturized scale matrix frameworks help encourage the incorporation of DG things inside the expansive electric lattice. Further, when genuine actualized, miniaturized scale lattices execute unbolt an expansive change with respect to stacked qualities for matrix administrators and jolted clients durability [12].

## II. SYSTEM DESCRIPTION

Fig. 1 delineates the improved outline of an independent Microgrid used to clarify the control procedure proposed in this paper. It comprises of a GFC, a GSC, and a battery bank.

Revised Manuscript Received on April 07, 2019.

Kosuri Sravani, Department of EEE, Godavari Institute of Engineering and Technology (A), Rajahmundry, India, 9989465290

I Solomon Raju, Department of EEE, Godavari Institute of Engineering and Technology (A), Rajahmundry, India,

The manageable power source, in this particular examination, is a variable speed wind turbine coupled to an interminable magnet synchronous generator (PMSG).

Dependent upon the system measure, other essentialness sources and other accumulating imperativeness structures can be scattered along the Microgrid. The ease of this structure is useful to exhibit the credibility of the proposed control methodology without losing comprehensive proclamation.

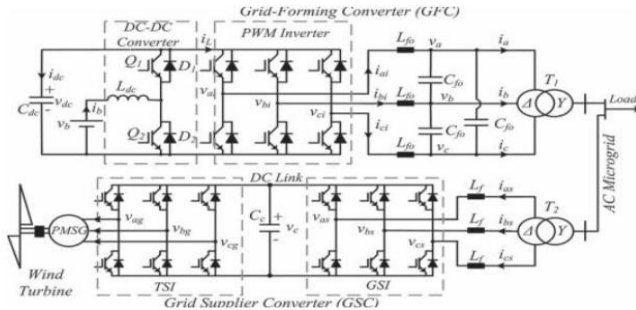

Fig.1. Simplified Diagram of the Studied Microgrid

The GFC is a bidirectional converter limited by a heartbeat width balance (PWM) three-mastermind inverter and a dc–dc converter that works in a buck mode when the battery bank is undercharge or in a lift mode when it is under release. The PWM inverter controls the degree and rehash of the Microgrid.

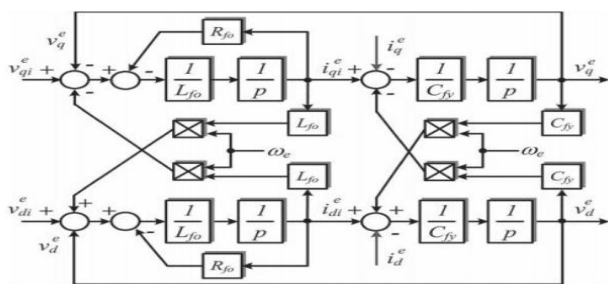

Fig.2. Block Diagram of LC Filter Implemented in a Synchronous Reference Frame

Voltage, while the dc–dc buck or lift converter is used to control the voltage at the dc transport capacitor (Cdc) which is the dc transport voltage similarly as the charging and discharging of the battery bank. The GSC is used to control the power made by the economical power source. In this particular point of reference, the converter is surrounded by a standard successive topology [12]. It has a structure side PWM inverter (GSI) and a breeze turbine-side PWM inverter (TSI). The GSI is used to control the dc-interface voltage of the back to back topology, and the TSI is used to control the power made by the breeze turbine reliant on a most extreme power point tracker (MPPT) count.

III. PROPOSED STRATEGY TO CONTROL THE GENERATED POWER IN THE MICROGRID

In remain solitary and circulated sustainable power source frame works, there is no business or traditional network to assimilate any surplus power produced inside in the Microgrid. In this way, the created control should be controlled when the heap control is not as much as the

measure of energy that could be produced by the vitality sources. This is fundamental to keep the importance change in the Microgrid leveled out and to keep the battery bank voltage underneath or level with its most unmistakable reasonable respect. This is basic since voltages higher than the gasification voltage can diminish the eventual fate of batteries or even fiendishness them irreversibly [13]. In the proposed control procedure, the GFC checks the battery bank voltage to know whether it achieved the most remarkable permitted charging voltage and, expecting this is the circumstance, change the Microgrid rehash to teach trade sources that they should diminish their made control. In context of the Microgrid rehash, the control structures of the power age sources related with the microgrid pick whether to restrict the power conveyed by all of them. This control system can be cleared up in context of Fig.3. While the terminal voltage of the battery bank is underneath its most uncommon point of confinement, the Microgrid rehash (f) is settled by the standard hang control framework, delineated by line C1 in Fig.3, since a physical or virtual inductance is fused when the line confirmation can't be neglected [7]. The recurrent respect is handled by (8), where kp is the incline steady of the line C1. On this condition, there are no controls about the extent of imperativeness that can be made, and the current possible power sources can manage their most vital power point. Clearly, this is genuine just if the battery bank has been made with adequate ability to ingest all the power that the reasonable sources can pass on at a given moment [14].

$$f = f_0 - k_p P_{inv}$$

On the other hand, if the best voltage of the battery bank is accomplished, the Microgrid repeat is compelled to be always higher than the regard fmax, which is the most extraordinary repeat of movement of the common hang control method. This is spoken to by the delivered district in Fig.3. By and by, the estimation of the repeat (f) is a variable that changes effectively [15].

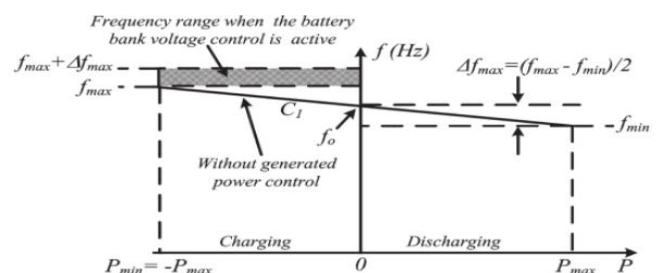

Fig.3. Frequency versus Power in the GFC Based on the Proposed Power Control

With the terminal voltage of the battery bank (vb), the power conveyed inside in the Microgrid (Pg), and the imperativeness of the GFC (Pinv). This can be bestowed by (9). As the estimation of the rehash relies on the development of the battery bank voltage controller, its association with the power (Pinv) does not take after an all around depicted arithmetical condition as, straight line.



In this manner, Fig. 10 exhibits just a delineation that the rehash can expect any a rousing power among  $f_{max}$  and  $f_{max} + \Delta f_{max}$ . In this working condition, it is basic to tie the extent of essentialness that can be made by boundless sources; overall, the reliability of the battery bank is in danger. The extent of essentialness that should be reduced from the most unprecedented power that each source can pass on at each minute has a control relationship with the recurrent capability  $\Delta f = f - f_{max}$ . The estimations of  $f_0$  and  $\pm \Delta f_{max}$  got a handle on in this work are 60 Hz and  $\pm 0.60$  Hz with the target that the recurrent degree of the Microgrid is between 59.4 Hz (sharp edge) and 61.2 Hz ( $f_{max} + \Delta f_{max}$ ).

$$f = f_{max} + \Delta f(v_b, P_g, P_{inv})$$

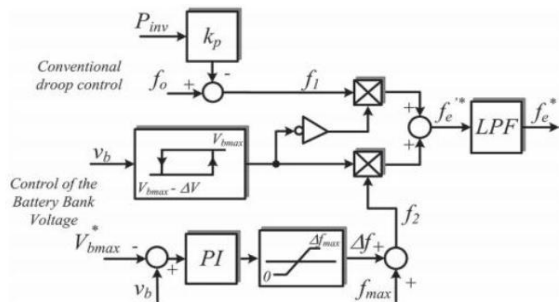

Fig.4. Block Diagram of the Frequency Control at the GFC

### A.Implementation of the Proposed Strategy in the GFC

The control of the battery bank voltage, to ensure its trustworthiness, was realized as showed up in Fig. 10. While the yield of the hysteresis circle is zero, the estimation of the repeat reference is  $f_e^* = f_1$ . Of course, while the yield of the hysteresis circle is one, a relative and irreplaceable (PI) controller is used to coordinate the terminal voltage of the battery bank meet or underneath its most extraordinary allowed regard ( $V_{bmax}$ ).

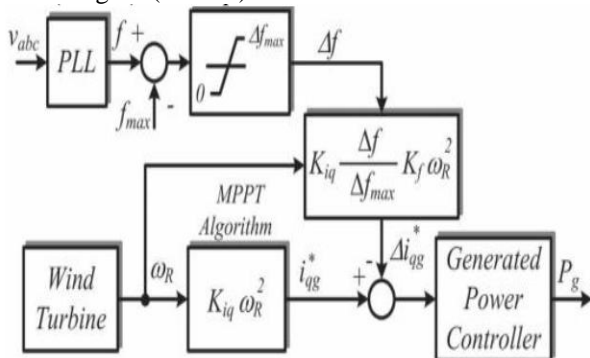

Fig.5. Block Diagram of the Power Control at the GSC

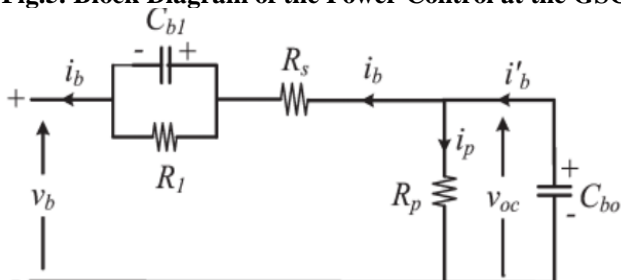

Fig.6. Lead-Acid Battery Equivalent Circuit

This controller is the augmentation of recurrence ( $\Delta f$ ) that must be added to the esteem  $f_{max}$  to frame the new Microgrid recurrence reference esteem ( $f_e^* = f_2 = f_{max} + \Delta f$ ). The

estimation of  $\Delta f$  is relative to the measure of intensity that must be decremented from the produced power so as to control the battery bank terminal voltage. The low-pass channel with a 1-Hz transfer speed appeared in Fig. 6 is utilized to dodge sudden varieties in recurrence due the hysteresis circle.

### B.Implementation of the Proposed Strategy in the GSC

The network rehash is assessed by the GSC and if its respect is higher than  $f_{max}$ , it proposes that the voltage of the battery bank is higher than its most unmistakable permitted respect. For the specific condition where the reasonable power source is a breeze turbine, the GSC power controller decrements the present reference  $i^* q$ , at first figured by (7), which is starting at now discovered by (10), where  $K_{fi}$  is an anticipated which serves to encourage the surveyed imperativeness of the GFC with the assessed essentialness of the breeze turbine. The square framework of this control movement is shown in Fig. 6

$$i_q^* = K_{iq} \left( 1 - \frac{\Delta f}{\Delta f_{max}} K_f \right) \omega_R^2$$

As the reference current is now determined by (6), the operating points of the wind turbine-generator set follow the dashed curve indicated by  $T_g$  in Fig. 5. This implies a reduction in the generator torque, which causes a reduction in power that is produced by the wind turbine keeping regulated the terminal voltage of the battery bank .

### C Tuning of the Battery Bank Terminal Voltage Controller

The tuning of the PI controller showed up in Fig. 10 considers the dynamic of the battery bank. One possible model for lead- unsafe batteries is showed up in Fig. 6. In this figure,  $v_{oc}$  is the battery open circuit voltage,  $R_s$  is the relating technique inside assertion,  $R_1$  and  $C_{b1}$  are used to show the over-or under voltage that happens when the battery is charging or discharging,  $R_p$  is the security due the run of the mill disasters, and  $C_{b0}$  models the battery capacity to bind importance. Commonly, the typical troubles happen a modest piece at any given moment, so the effect of  $R_p$  can be insulated with a complete objective of this work .

## IV. MATLAB/SIMULATION RESULTS

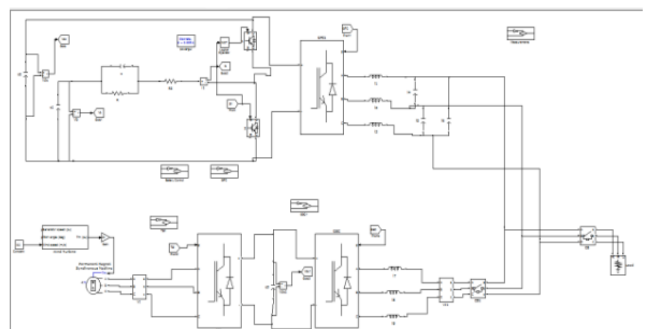

Fig.7. Matlab/Simulation Circuit of Simplified Diagram of the Studied Microgrid

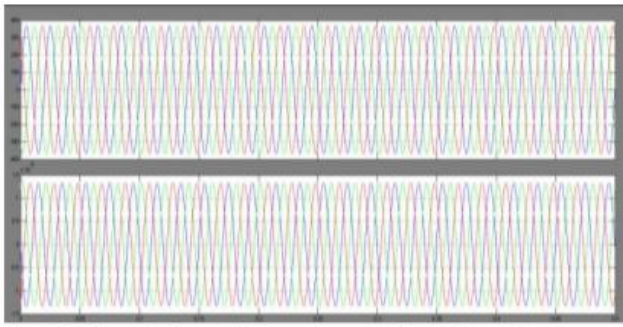

Fig.8. Simulation Wave Form of Grid Voltage and Current

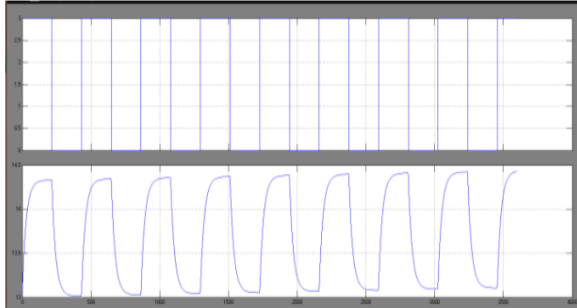
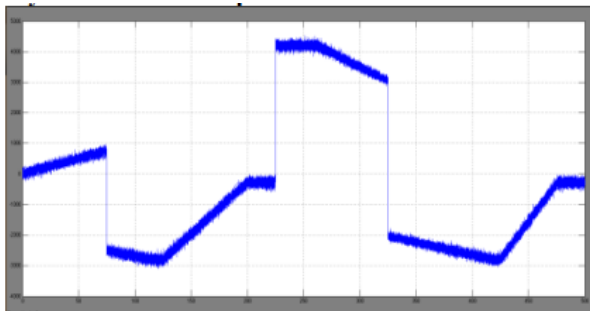
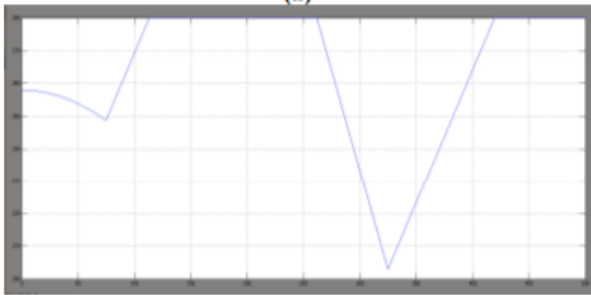

Fig.9. Simulation Wave Form of During the Tests with a 30-Ah 12-V Lead-Acid Battery Current and Voltage



(a)



(b)

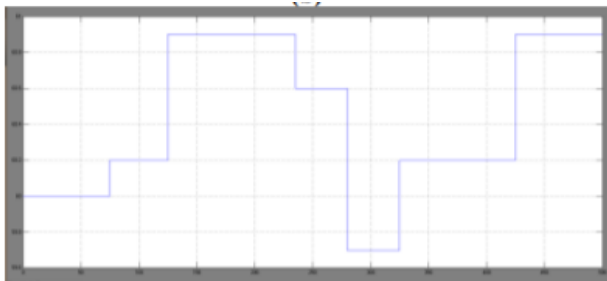

(c)

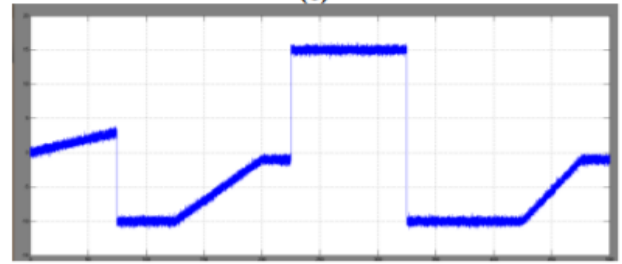

(d)

Fig.10. Simulation Wave Form of Operation with a Constant Wind Speed of 9.2 M/S: (a) Power at the GFC Terminals, (b) Battery Bank Voltage, (c) Microgrid Frequency, and (d) Battery Current

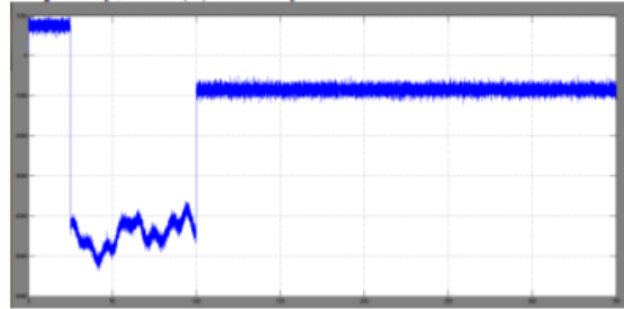

(a)

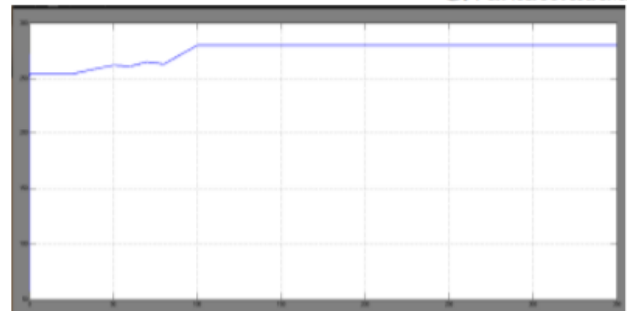

(b)

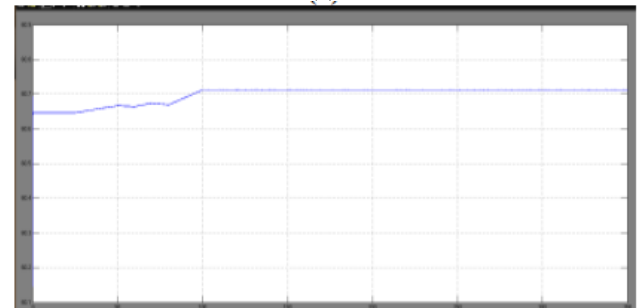

(c)

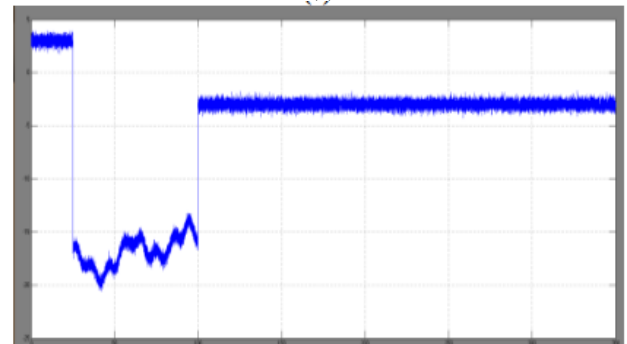

(d)

Fig.11. Simulation Wave Form of Peration with Variable Wind Speed: (a) Power at the GFC Terminals, (b) Battery Bank Voltage, (c) Microgrid Frequency, and (d) Battery Current.

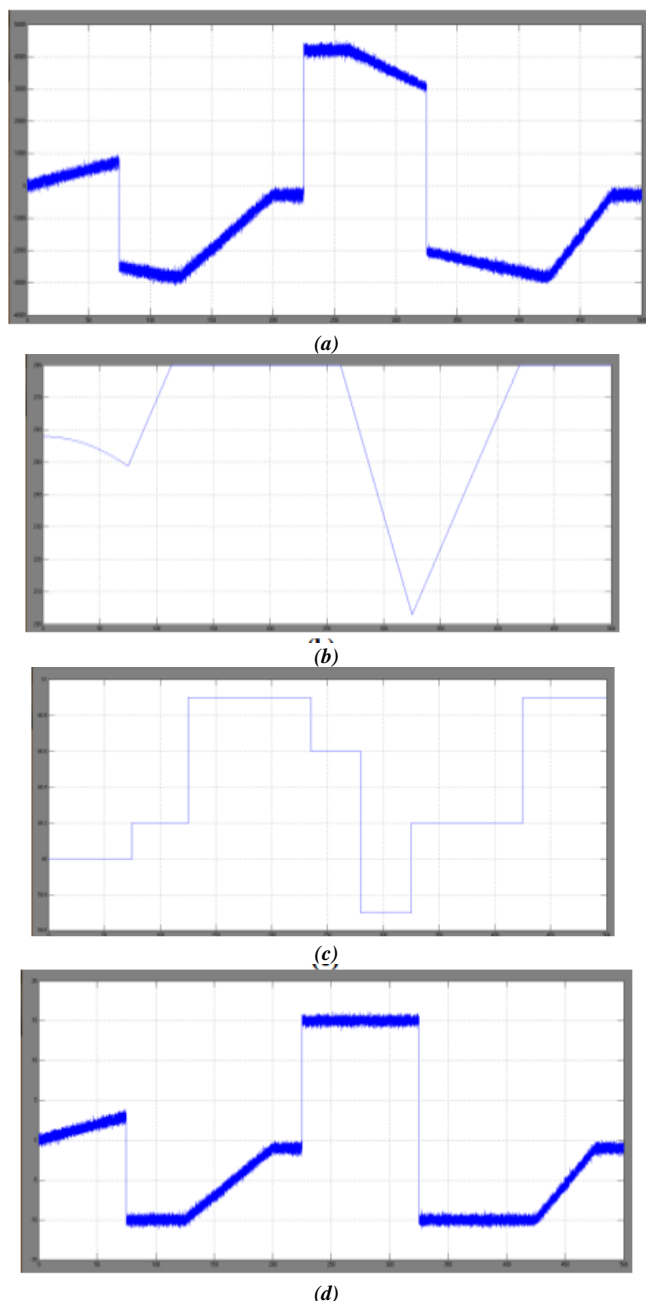

Fig.12. Simulation Wave Form of Operation with Variable Wind Speed with Fuzzy Controller: (a) Power at the GFC Terminals, (b) Battery Bank Voltage, (c) Microgrid Frequency, and (d) Battery Current

## V. CONCLUSION

This paper proposed controller is a procedure to fluffy rationale control the created control so as to monitor the charging voltage battery banks in remain solitary Microgrid with conveyed sustainable power sources. This system does not require wired correspondence between the conveyed sustainable sources nor dump burdens to scatter the excess of created control in the Microgrid. These particular positive conditions make the proposed procedure a promising instrument to fabricate the sensibility and immovable nature of the unlimited power age system presented in isolated and remote gatherings. Regardless of the way that a breeze turbine has been used to display the authenticity of the proposed system, it is also considerable paying little personality to the power source existing in the kept Microgrid. The proposed procedure figures the proportion of

vitality that must be made at each time by each source with a particular true objective to keep the modify of essentialness into the Microgrid . At the end of the day, the total of the created, expended, and put away vitality should dependably be zero constantly

## REFERENCES

1. José G. de Matos, Member, IEEE, Felipe S. F. e Silva, Student Member, IEEE, and Luiz A. de S. Ribeiro, Member, IEEE" Power Control in AC Isolated Micro grids With Renewable Energy Sources and Energy Storage Systems" IEEE Transactions On Industrial Electronics, Vol. 62, No. 6, June 2015.
2. L. A. de S. Ribeiro, O. R. Saavedra, S. L. de Lima, and J. G. de Matos, "Isolated micro-grid with renewable hybrid generation: The case of Lençóis island," IEEE Trans. Sustain. Energy, vol. 2, no. 1, pp. 1–11, Jan. 2011.
3. L. A. de S. Ribeiro, O. R. Saavedra, S. L. de Lima, and J. G. de Matos, "Making isolated renewable energy systems more reliable," Renew. Energy, vol. 45, pp. 221–231, Sep. 2012.
4. J. G. de Matos, L. A. de S. Ribeiro, and E. C. Gomes, "Power control in ac autonomous and isolated micro grids with renewable energy sources and energy storage systems," in Proc. IEEE IECON, 2013, pp. 1827–1832.
5. N. Mendis, K. M. Muttaqi, S. Pereira, and M. N. Uddin, "A novel control strategy for stand-alone operation of a wind dominated RAPS system," in Proc. IEEE IAS Annu. Meeting, 2011, pp. 1–8.
6. J. Chen, J. Cheng, C. Gong, and X. Deng, "Energy management and power control for a stand-alone wind energy conversion system," in Proc. IEEE IECON, 2012, pp. 989–994.
7. M. J. Erickson and R. H. Lasseter, "Integration of battery storage element in a CERTS Microgrid," in Proc. IEEE ECCE, 2010, pp. 2570–2577
8. J. Rocabert, J. A. Luna, F. Blaabjerg, and P. Rodríguez, "Control of power converters in ac microgrids," IEEE Trans. Power Electron., vol. 27, no. 11, pp. 4734–4749, Nov. 2012.
9. C. Jin, P. Wang, J. Xiao, Y. Tang, and F. H. Choo, "Implementation of hierarchical control in dc microgrids," IEEE Trans. Ind. Electron., vol. 61, no. 8, pp. 4032–4042, Feb. 2014.
10. X. Lu, K. Sun, J. M. Guerrero, J. C. Vasquez, and L. Huang, "State-of-charge balance using adaptive droop control for distributed energy storage systems in dc Microgrid applications," IEEE Trans. Ind. Electron., vol. 61, no. 6, pp. 2804–2815, Jun. 2014.
11. M. A. Abusara, J. M. Guerrero, and S. M. Sharkh, "Lineinteractive UPS for microgrids," IEEE Trans. Ind. Electron., vol. 61, no. 3, pp. 1292–1300, Mar. 2014.
12. J. M. Guerrero, P. X. Loh, T.-L. Lee, and M. Chandorkar, "Advanced control architectures for intelligent micro grids– Part II: Power quality, energy storage, ac/dc microgrids," IEEE Trans. Ind. Electron., vol. 60, no. 4, pp. 1263–1270, Apr. 2013.
13. Z. Chen, J. M. Guerrero, and F. Blaabjerg, "A review of the state of art of power electronics for wind turbines," IEEE Trans. Power Electron., vol. 24, no. 8, pp. 1859–1875, Aug. 2009.
14. T. Vijay Muni, D. Priyanka, S V N L Lalitha, "Fast Acting MPPT Algorithm for Soft Switching Interleaved Boost Converter for Solar Photovoltaic System", Journal of Advanced Research in Dynamical & Control Systems, Vol. 10, 09-Special Issue, 2018
15. T Vijay Muni, SVN Lalitha, B Krishna Suma, B Venkateswaramma, "A new approach to achieve a fast acting MPPT technique for solar photovoltaic system under fast varying solar radiation", International Journal of Engineering & Technology, Volume7, Issue 2.20, pp-131-135.

## AUTHORS PROFILE



Mrs. Kosuri Sravani, is pursuing Post Graduate, in EEE Department, Godavari Institute of Engineering and Technology (A), Rajahmundry, Andhra Pradesh, India



Mr. I. Solomon Raju (M.Tech), working as Assistant professor, in EEE Department, Godavari Institute of Engineering and Technology (A), Rajahmundry, Andhra Pradesh, India

