

# Coordinating the Power Grid with Integrated offshore Wind Farm and Marine Current Farm

K Chaitanya Madhuri, M Ramjee Sakpal

**Abstract:** *This paper deals with enhancement of power satisfactory enhancement of dynamic balance and voltage control of a grid linked integrated offshore wind farm and marine present day farm beneath some non- two linear prerequisites with STATCOM. In this paper, squirrel cage induction generator two (SCIG) is linked in parallel with marine cutting-edge farm, offshore wind farm and power storage system is carried out to simulate the characteristics of proposed system. In the proposed machine PID damping controller is designed for the STATCOM to stabilize the system under disturbance conditions. The voltage fluctuations of the AC bus state of affairs to lively electricity versions of the studied desktop can be successfully managed thru the proposed manage scheme.*

**Index Terms:** *Wind energy, Squirrel cage induction generator, Marine current rotary engine, sliding mode control.*

## I. INTRODUCTION

Both wind power and ocean strength are built-in along internal the U.K. Ocean strength may additionally want to encompass thermal energy, wave energy, offshore wind energy, periodic tournament energy, movement energy, etc. Generators pushed with the resource of marine-current rotary engine (MCT) mixed with offshore generators pushed by way of turbine (WT) can emerge as a certainly special theme for strength manufacturing inside the future. Since oceans cowl over seventieth surface of the planet, a hybrid electricity technology system containing each offshore power station (OWF) and marine-current farm (MCF) may be extensively developed at the precise areas of the planet inside the future. one amongst the effortless methods of running Associate in Nursing OWF is to connect the output terminals of many DFIGs along so hook up with an have an impact on grid through Associate in Nursing offshore transformer and subsurface cables. To run Associate in Nursing MCF could utilize numerous squirrel-confine acceptance generators (SCIGs) associated on to the office matrix through Associate in Nursing seaward transformer and subsurface links. each WTs Associate in Nursing the MCTs have horribly comparable operational qualities anyway a SCIG-based MCF needs receptive power for polarization while a DFIG-based OWF with 2 bi-directional power converters will the board its yield control issue to be going to solidarity. when the

produced dynamic intensity of Associate in Nursing SCIG-based MCF is shifted gratitude to marine-current changes, the retained receptive power and furthermore the terminal voltage of the MCF might be extensively influenced. inside the occasion of quickening framework aggravations, e.g., network flaws, Associate in Nursing vitality stockpiling framework or an influence gadget for an extensive scale high-limit control age framework is for the most part expected to repay precarious parts once interfacing with an impact lattice. An extensive scale OWF could blend with entirely unexpected FACTS gadgets or vitality stockpiling frame works like a STATCOM, and so on.

The broke down penalties of safety enhancement of depth frameworks abuse STATCOMs and moreover the damping controller style of STATCOMs were offered. the arranging of Associate in Nursing yield criticism direct quadratic managementler for a STATCOM and a variable cutting aspect pitch of a breeze vitality transformation framework to play out each voltage the executives and mechanical energy control below matrix association or islanding conditions. Framework exhibiting and controller style for snappy burden voltage direction and remedy of voltage gleam utilizing a STATCOM had been in contestible. a spic and span D-STATCOM the board rule empowering separate administration of positive-and negative-succession flows was once anticipated, and moreover the preferred was once bolstered the created scientific model inside the instructions for a D-STATCOM operational beneath unequal conditions [8-10]. Partner in Nursing inner and out examination of the dynamic execution of a STATCOM and a static synchronous association compensator (SSSC) abuse superior recreations was performed. The consequences of an investigation on the equipment of the as of late created STATCOM for the damping of torsional motions befell {in a |during a |in Associate in Nursing exceedingly |in a very} association stipendiary AC framework were examined whilst dynamic execution of the format with an extended STATCOM controller used to be assessed under a three-stage blame condition. Dialog and correlation of distinctive administration processes like PSS, static energy unit compensator (SVC) and STATCOM for damping bothersome interarea motions in power frameworks have been administrated. The normal approach of PI administration for a STATCOM used to be in contrast and contrasted with diverse comments administration methods, and a linear exceptional management supported LQR management was proven to be most effective in phrases of response profile and management effort needed.

**Revised Manuscript Received on April 07, 2019.**

**K Chaitanya Madhuri**, Department of EEE, Godavari Institute of Engineering and Technology (A), Rajahmundry., Rajahmundry, India.,

**M Ramjee Sakpal**, Department of EEE, Godavari Institute of Engineering and Technology (A), Rajahmundry., Rajahmundry, India,



## Coordinating the Power Grid with Integrated offshore Wind Farm and Marine Current Farm

A STATCOM supported a current-source electrical converter (CSI) was projected, and also the nonlinear model of the CSI used to be modified to be a linear model through a completely special modeling technique. The integrated STATCOM/BESS was once brought for the improve of dynamic and transient steadiness and transmission capability. The performance of a range of FACTS/BESS combos was in contrast and provided experimental verification of the projected controls on a scaled STATCOM/BESS system. A dynamic voltage management theme supported a combine of SVC and STATCOM technology on a related gear mechanism with IGs during a strength station used to be mentioned. This paper is geared up as below. The configuration and also the utilized models for the studied built-in OWF and MCF with STATCOM ar brought 1<sup>st</sup>. Then, the planning manner and fashion consequences for the inflammatory disease damping controller of the projected STATCOM mistreatment pole-placement technique are portrayed. every steady-state operation factors under various wind speeds and marine-current speeds and also the comparative dynamic responses of the studied gadget with and whilst now not the designed inflammatory sickness damping controller below a noise wind-speed disturbance, a marine-current speed disturbance, and a three-phase short-circuit fault at the grid are delineate later. Finally, specific vital conclusions of this paper are drawn .

### II. MODELING OF CASE STUDY

Fig. 1 demonstrates the design of the contemplated integrated DFIG-based OWF and SCIG based MCF with the proposed STATCOM. The 80-MW OWF is spoken to by a vast equivalent aggregated DFIG driven by a proportionate aggregated variable-speed WT through a comparable amassed gear box. The 40-MW MCF is spoken to by a substantial equal aggregated SCIG driven by an identical collected variable-speed MCT through an equal accumulated gearbox. The OWF, the MCF, the STATCOM and a neighborhood load are associated with an AC bus that is encouraged to the coastal power network through an offshore step-up transformer and undersea links. The utilized mathematical models of the concentrated framework are portrayed as underneath.

#### A. Wind Turbine

The mechanical power (in W) produced by a WT can be expressed by

$$P_{mw} = \frac{1}{2} \rho_w \cdot A_{rw} \cdot V_w^3 \cdot C_{pw}(\lambda_w, \beta_w) \quad (1)$$

Where  $\rho_w$  is the air density in kg/m<sup>3</sup>,  $A_{rw}$  is the blade impact area in m<sup>2</sup>,  $V_w$  is the wind velocity in m/s, and  $C_{pw}$  is the power coefficient of the WT. The wind pace is modeled as the algebraic sum of a base wind speed, a gust wind speed, a ramp wind speed, and a noise wind speed. The awesome equations for these 4 wind velocity factors can be referred to even as the electrical energy coefficient of the WT .

The cut-in, rated, and cut-out wind speeds of the studied WT are 4, 15, and 24 m/s, respectively. When  $V_w$  is decrease than the rated wind speed of the WT. When, the pitch-angle

manipulate device of the WT shown in Fig. 2 prompts and the pitch standpoint of the WT increases. Fig. three suggests the features of the captured per-unit mechanical power versus the per-unit generator rotor tempo of one of

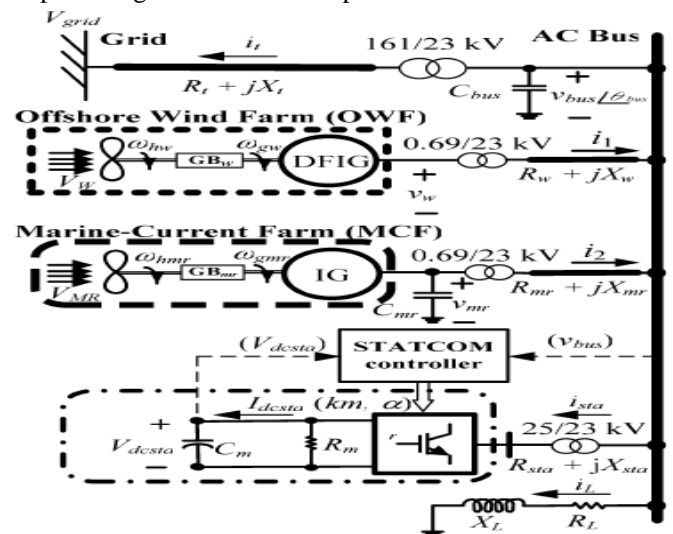

Fig. 1. Configuration of the integrated OWF and MCF with STATCOM.

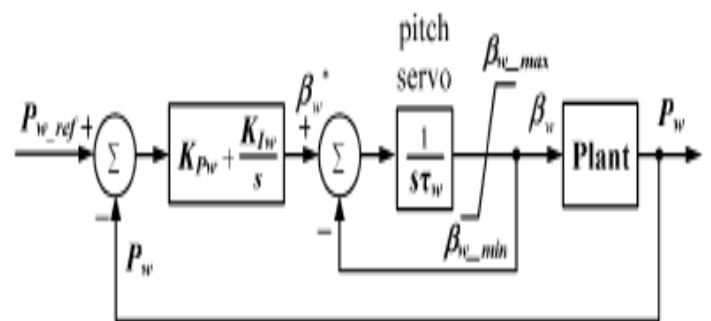

Fig. 2. Block diagram of the pitch-angle control system of the studied WT.

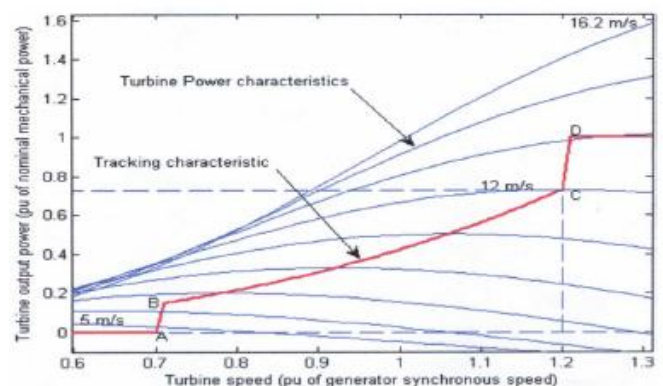

Fig. 3. Characteristics of turbine power versus generator rotor speed.

The forty 2-MW WTs of the studied 80-MW OWF from cut-in wind velocity to rated wind speed. The ast output points in Fig. three are the pleasant most output mechanical electricity of the WT.



B. Mass-Spring-Damper System and Induction Generator Fig. four suggests the two-inertia reduced-order equivalent mass-spring-damper mannequin of the WT coupled to the rotor shaft of

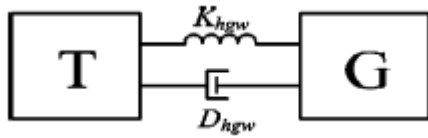

Fig. 4. Two-inertia reduced-order equivalent mass-spring-damper model of the

WT coupled to the rotor shaft of the studied wind DFIG.

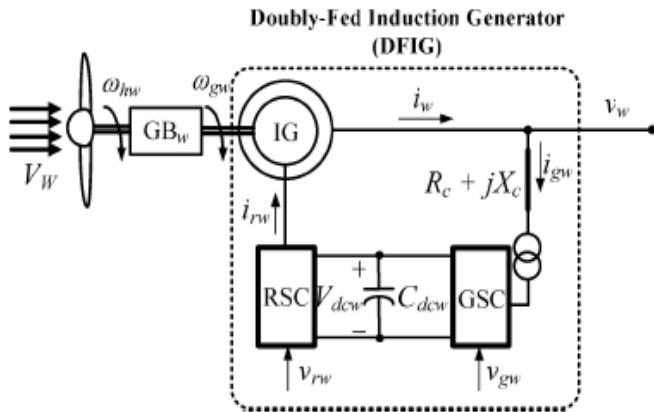

Fig. 5. One-line diagram of the studied doubly-fed induction generator.

The studied wind DFIG. The have an impact on of the equivalent gear box between the WT and the DFIG has been included in this model. The per-unit - and -axis voltage-current equations of an induction generator can be referred and they can be used for the electrical components of the wind DFIG and the marine current SCIG.

C. Power Converters of DFIG

Fig. 5 demonstrates the one-line outline of the reflected breeze DFIG. The stator windings of the breeze DFIG are particularly connected to the low-voltage side of the 0.69/23-kV assignment up transformer while the rotor windings of the DFIG are related with the same 0.69-kV aspect through a rotor-side converter (RSC), a DC interface, a grid-side converter (GSC), a stage up transformer, and a connection line. For normal venture of a breeze DFIG, the records AC-side voltages of the RSC and the GSC can be efficiently managed to achieve the factors of synchronous yield dynamic power and receptive power control. Fig.6 demonstrates the manipulate square format of the RSC of the examined DFIG. As regarded in Fig. 6, the operation of the RSC requires and to pursue the fluctuating reference points that are dictated by way of the usage of preserving up the yield active power and the stator-twisting voltage at the placing esteems, respectively. The required voltage for the RSC is derived by controlling the per-unit - and - pivot flows of the RSC. The manage rectangular chart of the GSC of the studied wind DFIG is seemed in Fig. 7. The per-unit - and - hub currents of the GSC and, prefer to follow the reference points that are dictated by means of the use of retaining up

the DC join voltage eat the putting outstanding and holding the yield of the GSC at unity control factor, individually. The required per-unit voltage of the GSC is inferred through controlling the per-unit - and - pivot flows of the GSC .

D. Marine-Current Speed and Marine-Current Turbine

The MCT is assumed to be driven by tide velocities, and the current pace is decided by means of spring and neap tides. The marine-current speed sare given at hourly intervals starting at 6 h before immoderate waters and ending 6 h after. It is handy to derive an easy and good mannequin for marine-current speed sunder the understanding tide coefficients as follows :

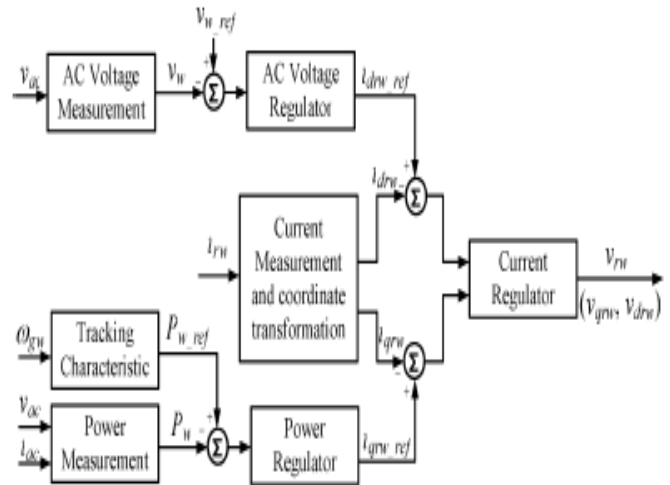

Fig. 6. Control block diagram for the RSC of the DFIG.

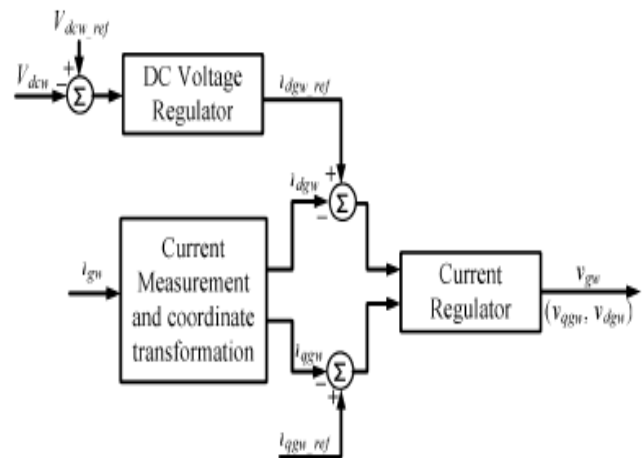

Fig. 7. Control block diagram for the GSC of the DFIG.

$$V_{MR} = V_{nt} + \frac{(C_{mr} - 45)(V_{st} - V_{nt})}{95 - 45} \tag{2}$$

Where Cmr is the marine coefficient, 95 and forty-five are the spring and neap tide medium coefficients, respectively, and are the spring and neap, marine-current speeds, respectively. The employed marine-current, mannequin is between France to England area.



The mechanical electricity(in W) generated by the studied, MCT can be expressed by way of

$$P_{\text{mmr}} = \frac{1}{2} \rho_{\text{mmr}} \cdot A_{\text{rmmr}} \cdot V_{\text{MR}}^3 \cdot C_{\text{pmr}}(\lambda_{\text{mmr}}, \beta_{\text{mmr}}) \quad (3)$$

Where Pmr is the seawater density in kg/m3 (Pmr=1025 kg/m3), Armr is the blade have an have an impact on on location in m2, VMR is the marine velocity in m/s as depicted in (2), and Cpmr is the power coefficient of the MCT.

The cut-in, rated, and cut-out speeds of the studied MCT are 1, 2.5, and four m/s, respectively. When is greater than the rated speed, the pitch-angle manage device of the MCT activates to limit the output power of the MCT at the rated value. Since the employed turbine model, pitch-angle manipulate system, and mass-spring-damper model of the studied MCF are similar to the ones that are employed in the OWF, some mathematical models employed in the OWF can be barely modified to be used in the MCF barring the parameters

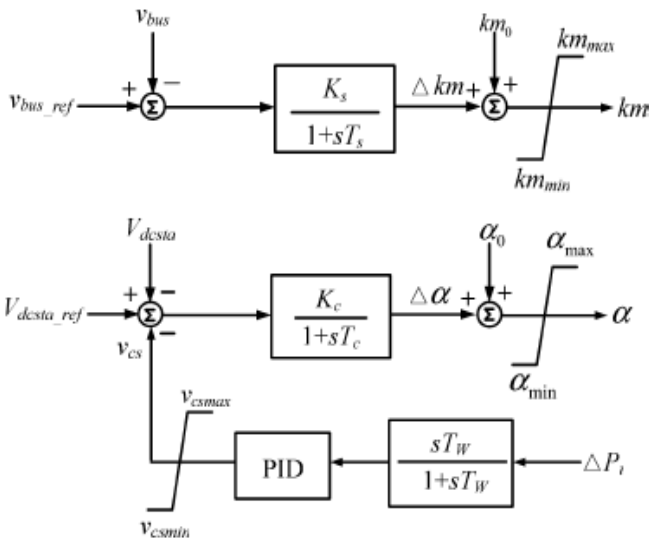

Fig. 8. Control block diagram of the proposed STATCOM including the designed PID damping controller.

E. STATCOM

The one-line graph of the studied STATCOM used to be shown in Fig. 1. The per-unit and -axis output voltages of STATCOM can be expressed by, respectively,

$$v_{q\text{sta}} = V_{\text{dcsta}} \cdot km \cdot \cos(\theta_{\text{bus}} + \alpha) \quad (4)$$

$$v_{d\text{sta}} = V_{\text{dcsta}} \cdot km \cdot \sin(\theta_{\text{bus}} + \alpha) \quad (5)$$

Where vq stand vd stare the per-unit q- and p-axis voltages at the output terminals of the STATCOM, respectively, theta bus is the phase perspective of the AC-bus voltage, Vdcstais the per-unit DC voltage of the DC capacitor Cm, and k mand alpha are the modulation index and segment attitude of the STATCOM, respectively. The per-unit DC voltage-current equation of the DC equivalent Capacitance Cm can be written as

$$(C_m)p(V_{\text{dcsta}}) = \omega_b [I_{\text{dcsta}} - (V_{\text{dcsta}}/R_m)] \quad (6)$$

Where

$$I_{\text{dcsta}} = i_{q\text{sta}} \cdot km \cdot \cos(\theta_{\text{bus}} + \alpha) + i_{d\text{sta}} \cdot km \cdot \sin(\theta_{\text{bus}} + \alpha) \quad (7)$$

III. SIMULATION RESULTS

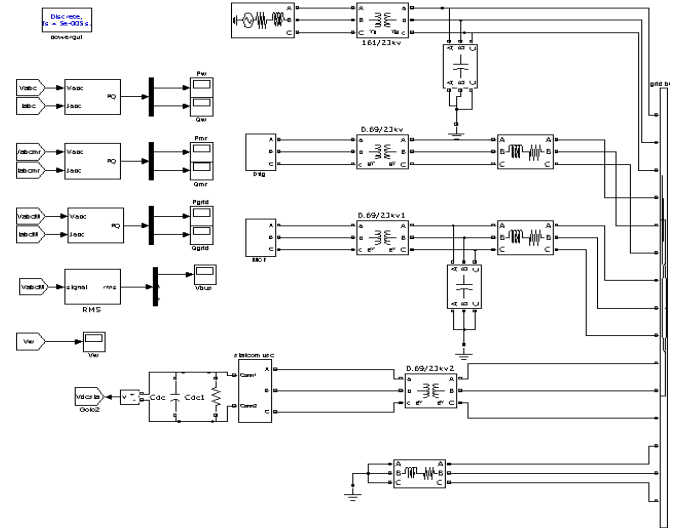

Fig: Simulation Diagram of Proposed System marine\_fig11WFMCF

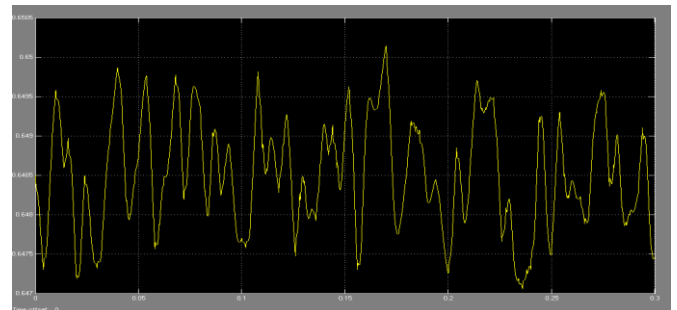

Fig: Active Power of Wind

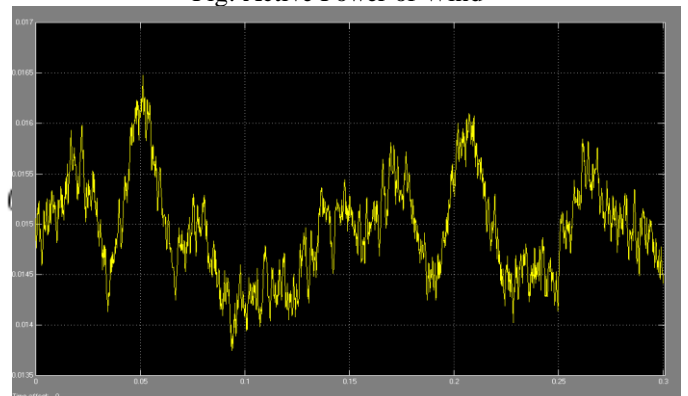
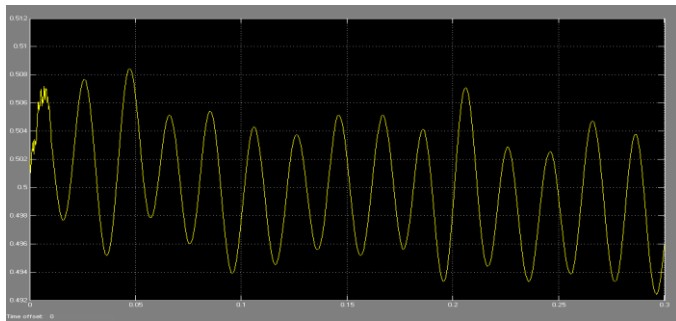
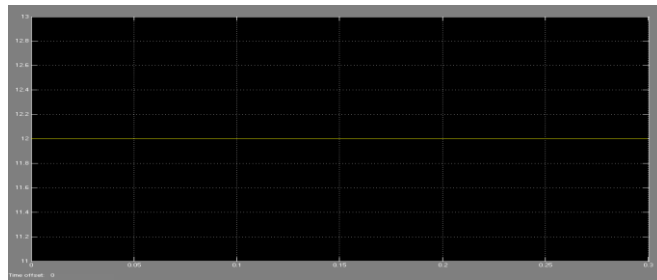

Fig: Reactive Power of Wind





Pmr



Vw marine\_fig1 WFMCFSTAT

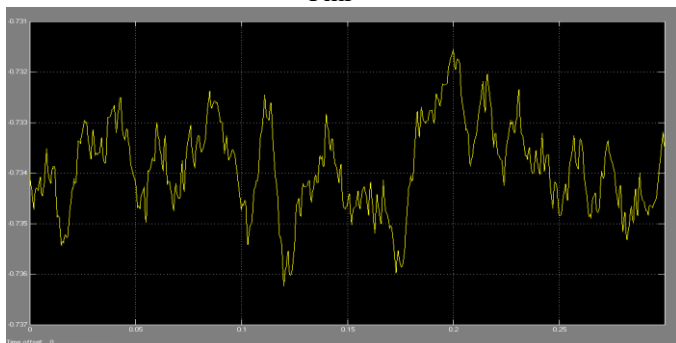

Qmr

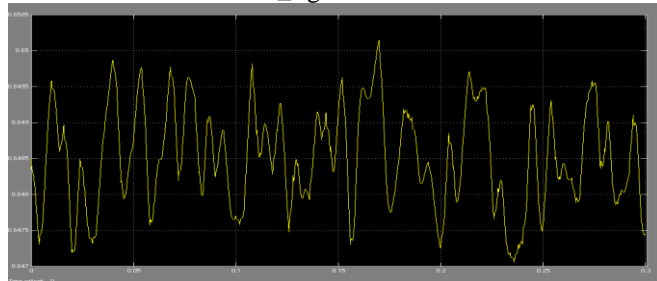

Pw

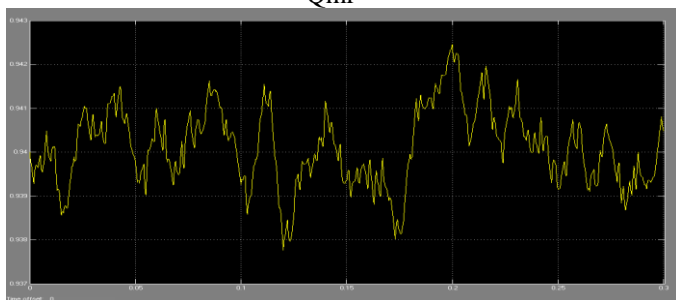

Pgrid

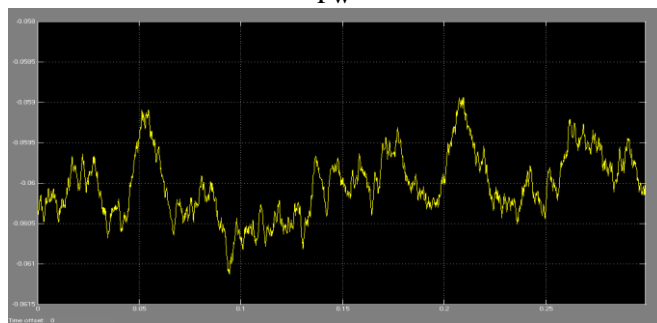

Qw

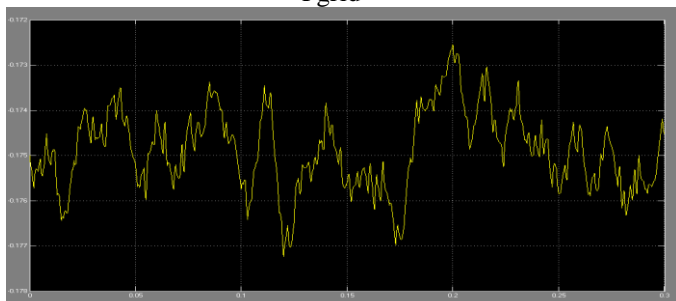

Qgrid

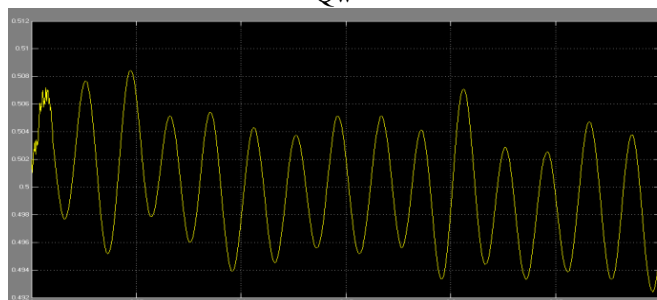

Pmr

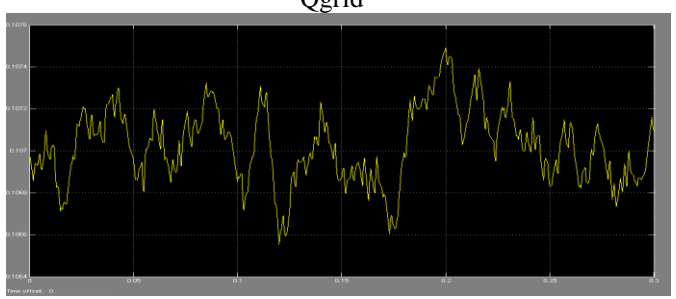

Vbus

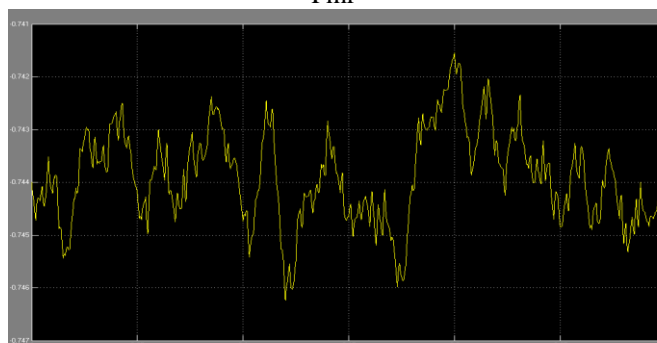

Qmr

# Coordinating the Power Grid with Integrated offshore Wind Farm and Marine Current Farm

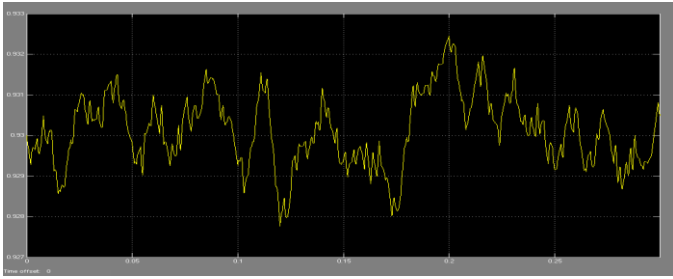

Pgrid

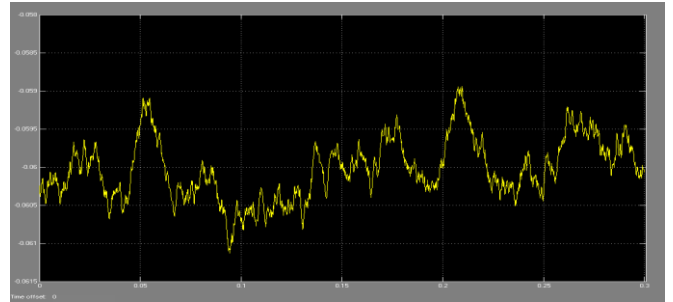

Qw

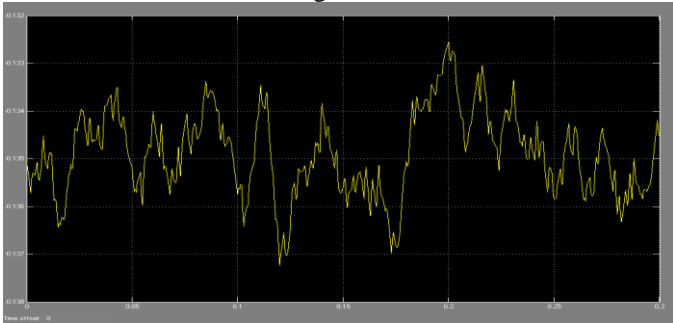

Qgrid

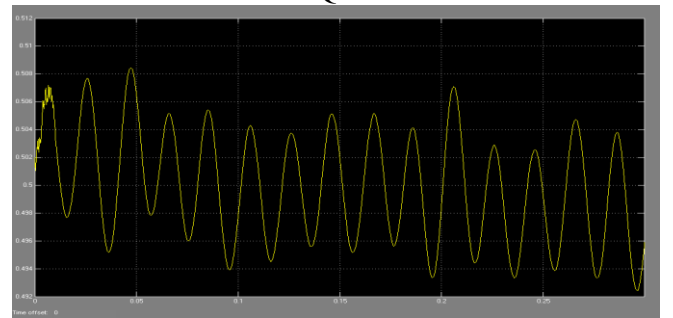

Pmr

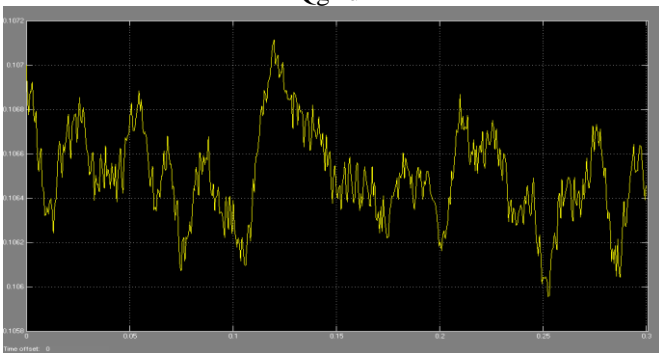

Vbus

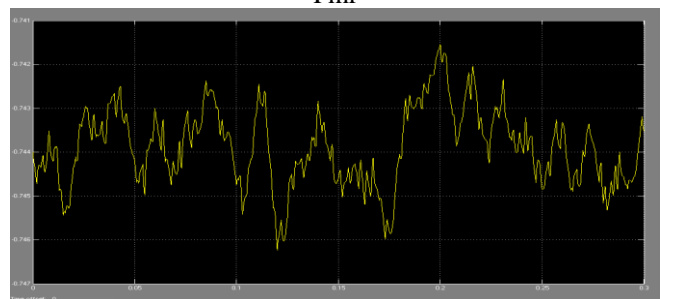

Qmr

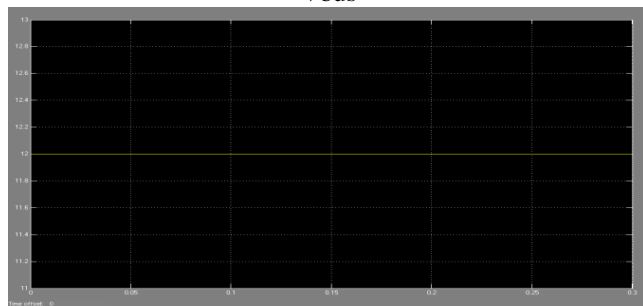

Vw

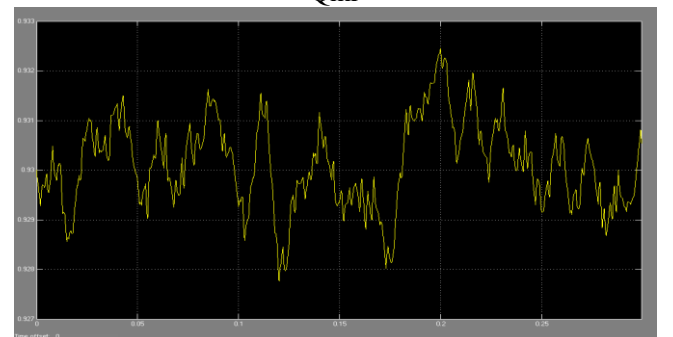

Pgrid

marine\_fig11WFMCFSTATPID

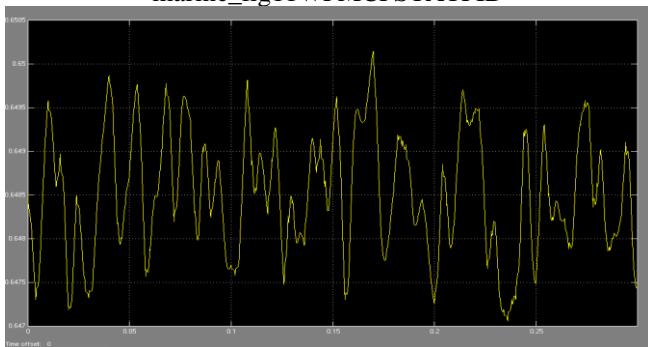

Pw

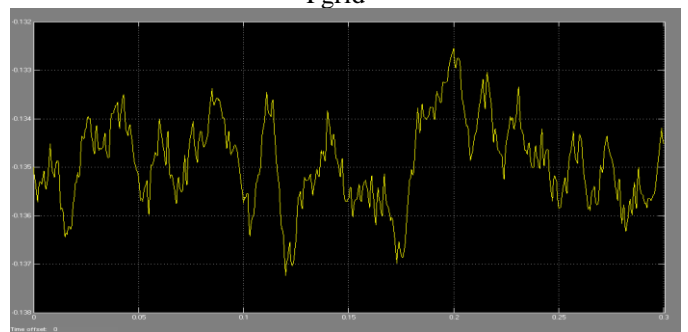

Qgrid

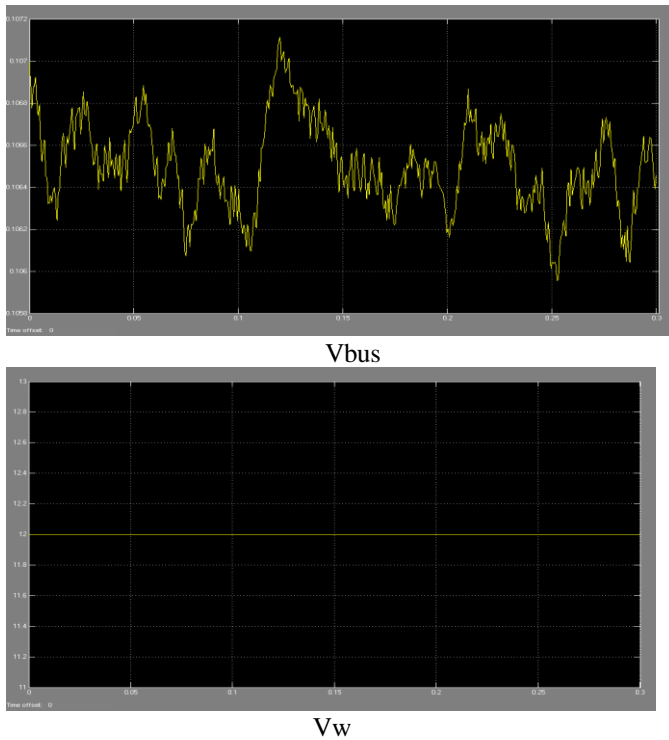

**Fig. 11.** Dynamic responses of the studied system with and without the PID STATCOM damping controller under a marine-current speed disturbance

#### IV. CONCLUSION

This paper has the dynamic stability improvement of an built-in OWF and MCF using a STATCOM. A PID damping controller has been designed for the STATCOM by using a unified strategy primarily based on pole-assignment approach .Eigen value calculations and time-area recreations of the studied framework concern to a commotion wind-speed unsettling influence, a marine-current velocity aggravation, and a three-stage short-circuit fault at the matrix have been effectively carried out to demonstrate the adequacy of the proposed STATCOM joined with the structured PID damping controller on suppressing voltage vacillation of the examined framework and end This paper has introduced the dynamic steadiness improvement of an built-in OWF and MCF the use of a STATCOM. A PID damping controller has been designed for the STATCOM by using a unified method specifically primarily based on pole-assignment approach .Eigen fee calculations and time-area recreations of the studied framework hassle to a commotion wind-speed unsettling influence, a marine-current velocity aggravation, and a three-stage short-circuit fault at the matrix have been efficaciously carried out to demonstrate the adequacy of the proposed STATCOM joined with the structured PID damping controller on suppressing voltage vacillation of the examined framework and bettering system dynamic soundness underneath extra than a few working conditions. It can be completed up from the reproduction consequences that the proposed STATCOM joined with the deliberate PID damping controller is capable of improving the execution of the examined integrated OWF and MCF underneath a range of working stipulations ancing system dynamic soundness

under a range of working conditions. It can be completed up from the reproduction effects that the proposed STATCOM joined with the deliberate PID damping controller is capable of improving the execution of the examined integrated OWF and MCF under various working prerequisites .

#### REFERENCES

1. S. E. B. Elghali, R. Balme, K. L. Saux, M. E. H. Benbouzid, J. F. Charpentier, and F. Hauville, "A simulation model for the evaluation of the electrical power potential harnessed by a marine current turbine," *IEEE J. Ocean. Eng.*, vol. 32, no. 4, pp. 786–797, Oct. 2007.
2. W. M. J. Batten, A. S. Bahaj, A. F. Molland, and J. R. Chaplin, "Hydrodynamics of marine current turbines," *Renewable. Energy*, vol. 31, no. 2, pp. 249–256, Feb. 2006.
3. L. Myers and A. S. Bahaj, "Simulated electrical power potential harnessed by marine current turbine arrays in the alderney race," *Renewable. Energy*, vol. 30, no. 11, pp. 1713–1731, Sep. 2005.
4. H. Chong, A. Q. Huang, M. E. Baran, S. Bhattacharya, W. Litzenberger, L. Anderson, A. L. Johnson, and A. A. Edris, "STATCOM impact study on the integration of a large wind farm into a weak loop power system," *IEEE Trans. Energy Convers.*, vol. 23, no. 1, pp. 226–233, Mar. 2008.
5. H. Gaztanaga, I. Etxeberria-Otadui, D. Ocnasu, and S. Bacha, "Real-time analysis of the transient response improvement of fixed-speed wind farms by using a reduced-scale STATCOM prototype," *IEEE Trans. Power Syst.*, vol. 22, no. 2, pp. 658–666, May 2007.
6. K. R. Padiyar and N. Prabhu, "Design and performance evaluation of sub synchronous damping controller with STATCOM," *IEEE Trans. Power Del.*, vol. 21, no. 3, pp. 1398–1405, Jul. 2006.
7. W. L. Chen and Y. Y. Hsu, "Controller design for an induction generator driven by a variable-speed wind turbine," *IEEE Trans. Energy Convers.*, vol. 21, no. 3, pp. 635–625, Sep. 2006.
8. VM Jyothi, TV Muni, SVN L Lalitha, "An optimal energy management system for pv/battery standalone system," *International journal of Electrical and Computer Engineering*, 2016.
9. T. Vijay Muni, D. Priyanka, S V N L Lalitha, "Fast Acting MPPT Algorithm for Soft Switching Interleaved Boost Converter for Solar Photovoltaic System", *Journal of Advanced Research in Dynamical & Control Systems*, Vol. 10, 09-Special Issue, 2018
10. T Vijay Muni, SVN L Lalitha, B Krishna Suma, B Venkateswaramma, "A new approach to achieve a fast acting MPPT technique for solar photovoltaic system under fast varying solar radiation", *International Journal of Engineering & Technology*, Volume7, Issue 2.20, pp-131-135.
11. A. Jain, K. Joshi, A. Behal, and N. Mohan, "Voltage regulation with STATCOMs: Modeling, control and results," *IEEE Trans. Power Del.*, vol. 21, no. 2, pp. 726–735, Apr. 2006.
12. B. Bl'az'ic and I. Papic, "Improved D-STATCOM control for operation with unbalanced currents and voltages," *IEEE Trans. Power Del.*, vol. 21, no. 1, pp. 225–233, Jan. 2006.
13. A. H. Norouzi and A. M. Sharaf, "Two control schemes to enhance the dynamic performance of the STATCOM and SSSC," *IEEE Trans. Power Del.*, vol. 20, no. 1, pp. 435–442, Jan. 2005.
14. K. V. Patil, J. Senthil, J. Jiang, and R. M. Mathur, "Application of STATCOM for damping torsional oscillations in series compensated AC system," *IEEE Trans. Energy Convers.*, vol. 13, no. 3, pp. 237–243, Sep. 1998.
15. N. Mithulananthan, C. A. Canizares, J. Reeve, and G. J. Rogers, "Comparison of PSS, SVC, and STATCOM controllers for damping power system oscillations," *IEEE Trans. Power Syst.*, vol. 18, no. 2, pp. 786–792, May 2003.
16. P. Rao, M. L. Crow, and Z. Yang, "STATCOM control for power system voltage control applications," *IEEE Trans. Power Del.*, vol. 15, no. 4, pp. 1311–1317, Oct. 2000.
17. Y. Ye, M. Kazerani, and V. H. Quintana, "Current-source converter based STATCOM: Modeling and control," *IEEE Trans. Power Del.*, vol. 20, no. 2, pp. 795–800, Apr. 2005.
18. Z. Yang, C. Shen, L. Zhang, M. L. Crow, and S. Atcity, "Integration of a STATCOM and battery energy storage," *IEEE Trans. Power Syst.*, vol. 16, no. 2, pp. 254–260, May 2001.
19. R. Griinbann, P. Halvarsson, D. Larsson, and P. R. Jones, "Conditioning of power grids serving offshore wind farms based on asynchronous generator," in *Proc. Conf. Power Electronics, Machine and Drives*, Mar./Apr. 2004, vol. 1, pp. 34–39.

20. P. M. Anderson and A. Bose, "Stability simulation of wind turbine system," *IEEE Trans. Power App. Syst.*, vol. PAS-102, pp. 3791–3795, Dec. 1983.
21. J. G. Slootweg, H. Polinder, and W. L. Kling, "Representing wind turbine electrical generating systems in fundamental frequency simulations," *IEEE Trans. Energy Convers.*, vol. 18, no. 4, pp. 516–524, Dec. 2003.
22. L. Wang, T.-H. Yeh, W.-J. Lee, and Z. Chen, "Evaluation of different control strategies on performance of a commercial wind farm," *Int. J. Elect. Eng.*, vol. 16, no. 2, pp. 133–150, Apr. 2009.
23. D. J. Trudnowski, A. Gentile, J. M. Khan, and E. M. Petritz, "Fixed speed wind-generator and wind-park modeling for transient stability studies," *IEEE Trans. Power Syst.*, vol. 19, no. 4, pp. 1911–1917, Nov. 2004.
24. S. M. Mueen, M. H. Ali, R. Takahashi, T. Murata, J. Tamura, Y. Tomaki, A. Sakahara, and E. Sasano, "Transient stability analysis of wind generator system with the consideration of multi-mass shaft model," in *Proc. Int. Conf. Power Electronics and Drives Systems*, Jan. 16–18, 2006, vol. 1, pp. 511–516.
25. P. Cartwright, L. Holdsworth, J. B. Ekanayake, and N. Jenkins, "Coordinated voltage control strategy for a doubly-fed induction generator (DFIG)-based wind farm," *Proc. Inst. Elect. Eng., Gen., Transm., Distrib.*, vol. 151, no. 4, pp. 495–502, Jul. 2004.
26. A. G. G. Rodriguez, A. G. Rodriguez, and M. B. Payán, "Estimating wind turbines mechanical constants," in *Proc. Int. Conf. Renewable Energies and Power Quality (ICREQP'07)*, Vigo, Spain, Mar. 27–30, 2007.
27. L. Ran, J. R. Bumby, and P. J. Tavner, "Use of turbine inertia for power smoothing of wind turbines with a DFIG," in *Proc. 2004 11th Int. Conf. Harmonics and Quality of Power*, Lake Placid, NY, Sep. 12–15, 2004, pp. 106–111.
28. Modeling New Forms of Generation and Storage, Jun. 2000, CIGRE, TF.01.10, 5th draft.
29. W.-K. Chen, *Linear Networks and Systems* (Book style). Belmont, CA: Wadsworth, 1993, pp. 123–135.
30. H. Poor, *An Introduction to Signal Detection and Estimation*. New York: Springer-Verlag, 1985, ch. 4.
31. B. Smith, "An approach to graphs of linear forms (Unpublished work style)," unpublished.
32. E. H. Miller, "A note on reflector arrays (Periodical style—Accepted for publication)," *IEEE Trans. Antennas Propagat.*, to be published.
33. J. Wang, "Fundamentals of erbium-doped fiber amplifiers arrays (Periodical style—Submitted for publication)," *IEEE J. Quantum Electron.*, submitted for publication.
34. C. J. Kaufman, Rocky Mountain Research Lab., Boulder, CO, private communication, May 1995.
35. VM Jyothi, TV Muni, SVN Lalitha, "An optimal energy management system for pv/battery standalone system," *International journal of Electrical and Computer Engineering*, 2016.
36. T. Vijay Muni, D. Priyanka, S V N L Lalitha, "Fast Acting MPPT Algorithm for Soft Switching Interleaved Boost Converter for Solar Photovoltaic System", *Journal of Advanced Research in Dynamical & Control Systems*, Vol. 10, 09-Special Issue, 2018
37. T Vijay Muni, SVN Lalitha, B Krishna Suma, B Venkateswaramma, "A new approach to achieve a fast acting MPPT technique for solar photovoltaic system under fast varying solar radiation", *International Journal of Engineering & Technology*, Volume7, Issue 2.20, pp-131-135.
38. Y. Yorozu, M. Hirano, K. Oka, and Y. Tagawa, "Electron spectroscopy studies on magneto-optical media and plastic substrate interfaces(Translation Journals style)," *IEEE Transl. J. Magn.Jpn.*, vol. 2, Aug. 1987, pp. 740–741 [*Dig. 9<sup>th</sup> Annu. Conf. Magnetics Japan*, 1982, p. 301].
39. M. Young, *The Technical Writers Handbook*. Mill Valley, CA:

### AUTHORS PROFILE



Miss. K. Chaitanya Madhuri, PG Student, EEE department, Godavari institute of engineering and technology (A), Rajahmundry. katarimadhuri@gmail.com



Ramjee SAKPAL Mortha currently works at the Department of Electrical and Electronics Engineering, Godavari Institute of Engineering and Technology. Ramjee does research in Electronic Engineering and Electrical Engineering. I studied by B. tech at JNTUK college of engineering Vizianagaram and M. tech from NIT Calicut. I am having membership in IAENG,