

# Interior Wall Painting and Designing Robot

Debargha Roy, D. Deva Hema, Rohit Roy, Arpit Agrawal, Mayukh Biswas

**Abstract**— This paper presents a methodology for developing a paint robot, which is capable of performing paint job on an interior wall. The method combines features such as detection of the surface roughness, paint viscosity, paint thickness prediction, and complex design patterns printing on the wall.

**Index Terms:** paint robot, wall design paint, paint thickness measurement, surface roughness detection, Cartesian system

## I. INTRODUCTION

Ever since the advent of the robots in the industry there have been development of multiple types of robots for various purposes that comprises of areas such as manufacturing industries, construction sites, etc. Over the years, there has been consistent efforts that could lead to the development of a robot that is capable of performing the paint operation of the interior walls of the homes. This idea is the combination of mixing robotics in painting industry is widely known where the design is complex and the painting should be time efficient and easy to handle to achieve absolute results.

The idea proposed here, is to develop a robot that is capable of identifying the roughness of the surface, which is to be painted, to reduce the wastage of paint. The bot also measure the viscosity of the paint that it is supplied with to ensure the amount of paint that is being applied provides a uniform texture every time it is used for the application, thereby ensuring a consistent quality over period. The robot is also capable of autonomously adjusting the distance from the wall during its movements, to ensure that the paint applied is been uniformly done with the flawless design.

This idea increases the efficiency of the robot in implementing complex designs on the walls that may be needed by the consumers or the clients. Such designs, which has high chances of getting wrong colors, and custom design by the artist on the bigger scale. The target of the robot is to implement the design accurately even if it takes a bit more time with high degree of accuracy.

## II. PROPOSED SYSTEM

### A. Construction

**Revised Manuscript Received on June 10, 2019.**

**Debargha Roy**, Department of Computer Science and Engineering, SRM Institute of Science and Technology, Chennai, India.

**D. Deva Hema**, Department of Computer Science and Engineering, SRM Institute of Science and Technology, Chennai, India.

**Rohit Roy**, Department of Computer Science and Engineering, SRM Institute of Science and Technology, Chennai, India.

**Arpit Agrawal**, Department of Computer Science and Engineering, SRM Institute of Science and Technology, Chennai, India.

**Mayukh Biswas**, Department of Computer Science and Engineering, SRM Institute of Science and Technology, Chennai, India.

The paint robot consists of a basboard mounted on centrally controlled four wheels that help the complete system in moving from one point to another in a room. All other components are mounted on this board.

Following are the important components of the system:

- Paint container
- Paint spray system Control module
- Sensor and sensor network
- Surface roughness detection tool
- Viscosity detection tools
- User input tools touch display with a scanner
- Motor networks
- Image processing

Inspired by the proposed Cartesian system, the system utilizes the x- and z-axis module eliminating the y-axis module, as the y-axis movements will be taken care of by the x-axis module with the wheels being rotated along 90°.

### B. Working

The working of the system is divided into stages which are as follows:

1) *Input Stage*: The system initiates by taking input about the dimensions of the walls followed by scanning any image of design that is to be painted on the wall. The image of the design preferably be drawn on a white paper and better if printed form designed in a computer. This is followed by filling of the paint container with the color (emulsion) that is to be applied on the wall in the Paint Container.

2) *Detection Stage*: The paint provided in the container is passed through wireless magneto-acoustic testing for estimating the viscosity of the paint. The machine is designed to be able to vary the pumping pressure for variation in the viscosity of the paint provided. The system then detects the distance of the wall that is to be painted. If the wall is at an optimum distance from the system, it proceeds with detecting the either end of the wall. The machine moves to the left/right wall depending upon whichever is closure to it. It then initiates the system to move to nearest side wall. The system then detects that roughness of the wall surface using the Speckle Correlation Technique. The information thus obtained is passed on to the paint quantity determination stage.

3) *Paint Quantity Determination Stage*: The information from Viscosity Detection and Roughness Detection is used to estimate the paint flow rate at nozzle using the painting parameters stated in the relation as described in Automatic Trajectory Planning System



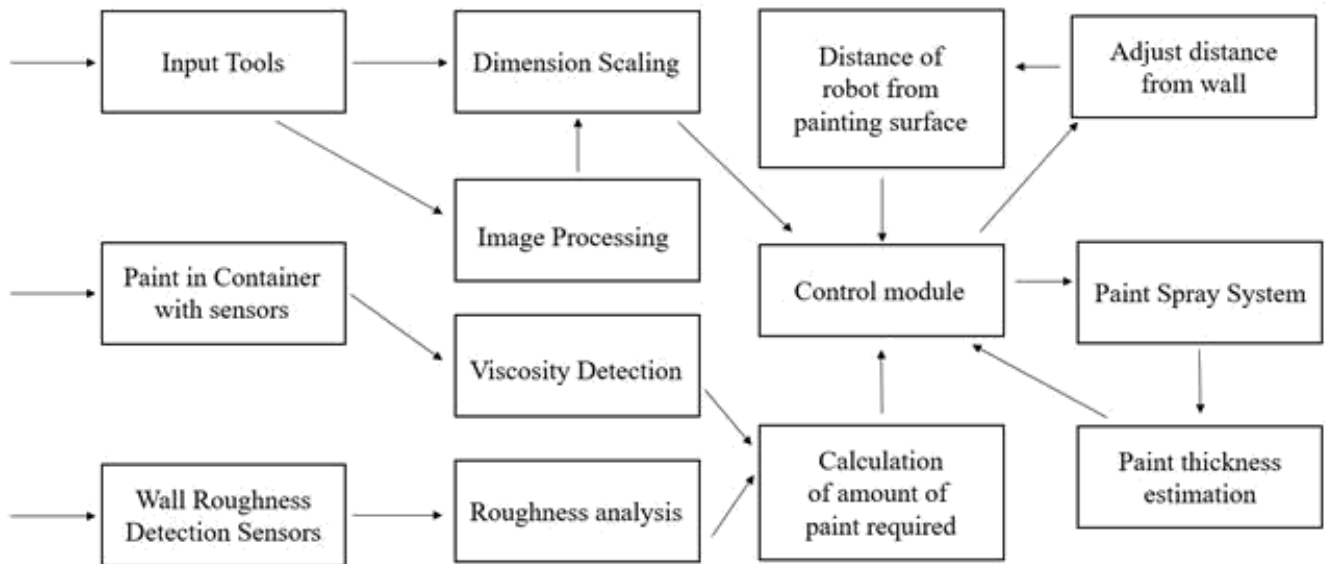

Fig. 1. System Work-Flow

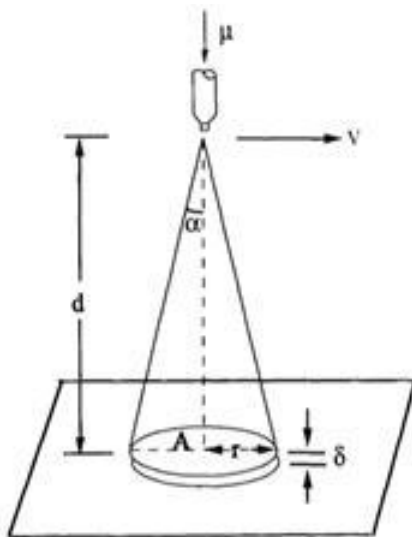

Fig. 2. Flow rate determination

4) **Painting Stage:** The paint is fetched from the container and is sent to the atomizer for spraying action to be carried out. The paint is then forced out of the nozzle, targeting the wall to be painted. The paint operation can be performed in two ways, which are covered in later sections.

5) **Paint Thickness Estimation Stage:** Once the paint is applied, the thickness of the paint is estimated with the formula stated before, interchanging and on either side of the equations. Additional, roughness detection systems are deployed to find the roughness that finally available. If the final data thus obtained is consistent with the recommended data, the system proceeds for the next segment, else the paint

operation is re-performed. A point worth considering here is, this stage is carried out once the paint has dried and not immediately following the paint operation. G. **Proceed Stage** In this stage, the system id moved forward for completing the paint operation on the remaining wall. The system travels a distance  $d$ , such that  $d$  is the length of the system parallel to the wall being painted.

6) **Proceed Stage:** The system moves forward for completing the paint operation on the remaining wall. The system travels a distance  $d$ , such that  $d$  is the length of the system parallel to the wall being painted.

### C. Paint Operation

The paint operation as stated above can be performed in two ways, in continuous manner, and discrete (step) manner. Each of these are discussed below.

1) **Continuous Manner:** In this type of operation, the paint nozzle is moved continuously over the surface while the paint is being sprayed on it. The end result is the production of a layer of paint that might look as illustrated in figure 3 if not done properly.

2) **Discrete (Step) Manner:** This type of paint operation, usually is obtained by filtering and restricting the paint generated by the Continuous method to a certain area for a time cycle, during which the area is continuously exposed to the paint operation. The end result is the production of paint as illustrated in figure 4. The resulting operation relatively more confined to a well-defined region, thereby making the paint job easy and predictable in nature.

From the above two situations, it is clear that the second approach of discrete painting is more predictable and preferred.

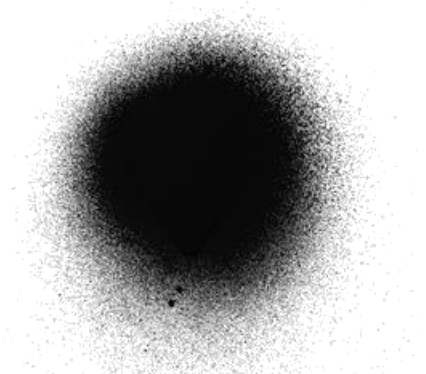

Fig. 3. Continuous Spray Painting



Fig. 4. Discrete Spray Paint

### D. Painting Nozzle and Arm Construction

In continuation to the problem and the solution stated previously, the paint nozzle has been redesigned a bit to achieve the purpose easily. The figure of the paint nozzle is shown in figure 5.

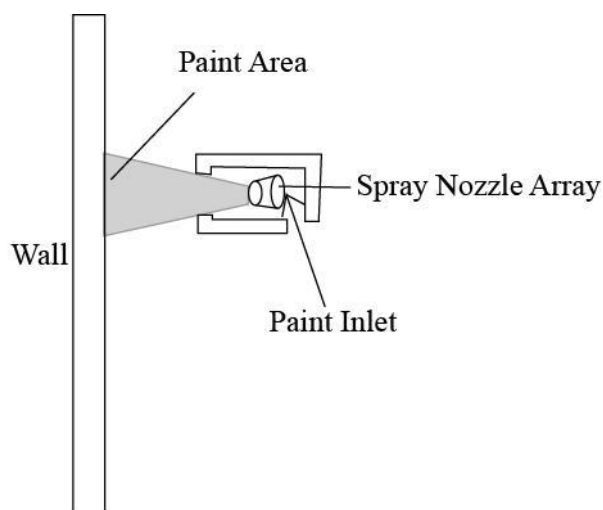

Fig. 5. Paint Spray Nozzle

Multiple spray nozzles are combined to form an array as in figure 6, which are controlled in combination. The nozzle array is mounted on a rack-and-pinion gear system which makes the array move in vertical direction for covering the wall along the height. The horizontal motion of the nozzles are controlled by the horizontal motion of the complete system.

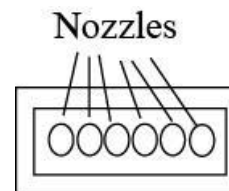

Fig. 6. Nozzle Array

## III. RESULTS

### A. Paint Operation

A normal paint operation consisting of applying only one color to the wall is performed using the methods stated previously.

The same can be used for painting walls with multiple colors, provided the colors are to be painted only in rectangular shapes. This can be achieved by filling the paint container with different paints and manually controlling the paint operation.

### B. Implementation of Complex Design

The technique used in implementation of complex design involves the bifurcation of the design into small and distinct geometric shapes that can be easily painted with the spray nozzle provided with the system.

The system visualizes the complete paint surface as a Cartesian plane on which the image is plotted from a starting coordinate to another ending coordinate of rectangular figures, or is depicted as a given set of points which encloses the given diagram. It then proceeds with the application of paint to the discrete individually identical geometric shapes that are part of the image.

The image, following the Cartesian coordinate system on the x y plane, considers the bottom left corner of the wall to be the (0; 0) coordinate, and thereby rendering the image at coordinates (x; y) from the defined origin. The point worth noting with the system is, it keeps a track of the portion of the image already rendered on the wall and the part of image yet to be rendered. The system can resume the paint operation by moving to the last worked coordinate, providing it the capability to incorporate multiple colors on the image as the work can be paused to change the paint as and when desired

## IV. CONCLUSIONS

The system thus proposed above, is expected to solve the a major challenge that a paint robot may face on how to implement a design on a given wall. Also the techniques employed by the system are expected to provide a much better paint finishing when working on walls with varying roughness. The system basically has two degrees of freedom, along the z axis and along either the x or the y axis.

The system is expected to improve the overall cost factors of the painting job. On the contrary, the time factor of the paint application when compared to the humans working on the same depends greatly on the type of paint operation to be performed. If the paint is to be applied just as a single paint over the complete wall, the system is expected to perform faster when compared to the human labor, but as far as implementing complex designs are concerned, the time factor is expected to be higher because of the various curve planning, along which the paint operation is to be performed.

### ACKNOWLEDGMENT

We would like to acknowledge Kues1 at [https://www.freepik.com/free-photo/spraypaint\\_1012362.htm](https://www.freepik.com/free-photo/spraypaint_1012362.htm) for figure 3 and figure 4.

### REFERENCES

1. M. K. Jain, S. Schmidt, C. Mungle, K. Loisselle and C. A. Grimes, "Measurement of temperature and liquid viscosity using wireless magneto-acoustic/magneto-optical sensors," in IEEE Transactions on Magnetics, vol. 37, no. 4, pp. 2767-2769, July 2001.
2. Lger, E. Mathieu, and J. C. Perrin, "Optical Surface Roughness Determination Using Speckle Correlation Technique," Appl. Opt. 14, 872-877 (1975).
3. Suk-Hwan, SuhIn-KeeWoo, Sung-KeeNoh, "Automatic trajectory planning system (ATPS) for spray painting robots," Journal of Manufacturing Systems, Vol. 10, Issue 5, 1991.
4. Aris, A. K. M. Parvez Iqbal, A. R. Ramli, and S. Shamasuddin, "Design and Development of a Programmable Painting Robot for Houses and Buildings," Jurnal Teknologi, 42(A) Jun. 2005: 2748.
5. Abraham Warszawski, and Yechiel Rosenfeld, "Robot for Interior-Finishing Works in Building: Feasibility Analysis," Journal of Construction Engineering and Management, Vol. 120, Issue 1 (March 1994).
6. Peter Hertling, Lars Hog, Rune Larsen, John W. Perram, and Henrik Gordon Petersen, "Task Curve Planning for Painting Robots Part I: Process Modelling and Calibration," IEEE Transactions On Robotics And Automation, Vol. 12, Nn. 2, April 1996.
7. M. A. Sahir Arikian, and Tuna Balkan, "Process Simulation and Paint Thickness Measurement for Robotic Spray Painting," CIRP Annals, Volume 50, Issue 1, Pg. - 291-294 .
8. M. Omar V. Viti K. Saito J. Liu, (2006), "Self-adjusting robotic painting system", Industrial Robot: An International Journal, Vol. 33 Iss 1 pp. 50-55.
9. Young S. Kim, Myung H. Jung, Yong K. Cho, Jeongho Lee, and Unsuk Jung, "Conceptual Design and Feasibility Analyses of a Robotic System for Automated Exterior Wall Painting", International Journal of Advanced Robotic Systems, December 1, 2007.
10. Pranil Vijay Sawalakhe, Nitish, and Tanmaya, Naba, "Fabrication of Painting Robot based on automated Technology," Imperial Journal of Interdisciplinary Research (IJIR) Vol-2, Issue-5, 2016.
11. Berardo Naticchia, Alberto Giretti and Alessandro Carbonari, "Set Up of an Automated Multi-Colour System for Interior Wall Painting," International Journal of Advanced Robotic Systems, Vol. 4 No. 4 (2007).
12. G. Vasumathi, and S. Elakkiya, "AUTOMATIC ROBOTIC SPRAY PAINTING OF LOW VOLUME HIGH VARIANT PARTS," International Journal of Pure and Applied Mathematics, Volume 116 No. 20 2017, 437-441.
13. Boon Ean Teoh and S. V. Ragavan, "PAINTbot - FPGA based wall painting service robot prototype," IEEE Recent Advances in Intelligent Computational Systems, Trivandrum, 2011, pp. 777-782.
14. Boon Ean Teoh, and S. Veera Ragavan, "PAINTbot FPGA Based Wall Painting Service Robot Prototype," IEEE Recent Advances in Intelligent Computational Systems, 2011.
15. Joris De Schutter, Tinne De Laet, Johan Rutgeerts, Wilm Decr, Ruben Smits, Erwin Aertbelin, Kasper Claes, and Herman Bruyninck, "Constraint-based Task Specification and Estimation for Sensor-Based Robot Systems in the Presence of Geometric Uncertainty," The International Journal of Robotics Research Vol. 26, No. 5, May 2007, pp. 433-455.
16. Jitendra N. Shelar, and Prof. N. R. Gilke, "Conceptual Design Of Fix-ture For Automate Exterior Wall Painting And Design And Analysis. Its Main Component," International Journal of Innovative Research and Development," Vol. 2 Issue 5, May 2013
17. T. S. Mohammad Zaid and A. Arockia Selvakuma, "Development of Exterior Wall Painting Robot," Indian Journal of Science and Technology, Vol 9(38), October 2016.
18. Mohamed Abdellatif, "Design of An Autonomous Wall Painting Robot," First International Symposium on Socially, 2012.
19. Ewa Kolakowska, Stephen F. Smith, and Morten Kristiansen, "Constraint optimization model of a scheduling problem for a robotic arm in automatic systems", Robotics and Autonomous Systems, Vol 62, Issue 2, February 2014, Pages 267-280.
20. Aris, Ishak & Parvez Iqbal A. K., M & A. R., Ramli & Sulaiman, Shamsuddin. "Design and Development of a Programmable Painting Robot for Houses and Buildings". 2012.