

# Design and Analysis of Piezoelectric Energy Harvesting Systems

Ravi Shekhar , Prakash Kumar

**Abstract:** This Paper presents a new technique of electrical energy generation using mechanically excited piezoelectric materials and a nonlinear process. This technique, called double synchronized switch harvesting (DSSH), is derived from the synchronized switch damping (SSD), which is a nonlinear technique previously developed to address the problem of vibration damping on mechanical structures. This technique results in a significant increase of the electromechanical conversion capability of piezoelectric materials. An optimized method of harvesting vibrational energy with a piezoelectric element using a dc-dc converter is presented. In this configuration, the converter regulates the power flow from the piezoelectric element to the desired electronic load. Analysis of the converter in discontinuous current conduction mode results in an expression for the duty cycle-power relationship. Using parameters of the mechanical system, the piezoelectric element, and the converter; the “optimal” duty cycle can be determined where the harvested power is maximized for the level of mechanical excitation. A circuit is proposed which implements this relationship, and experimental results show that the converter increases the harvested power by approximately 365% as compared to when the dc-dc converter is not used.

**Index Terms:** Adaptive Control DC-DC Conversion Energy Harvesting Piezoelectric Devices DSSH.

## I. INTRODUCTION

“Piezoelectricity is the electric charge that accumulates in certain solid materials (such as crystals, certain ceramics, and biological matter such as bone, DNA and various proteins) in response to applied mechanical stress”. The piezoelectric effect is a two way process. Piezoelectric materials that generate electrical charge on application of mechanical force (called direct piezoelectric effect) can also show mechanical strain on application of electric field (called reverse piezoelectric effect).

Piezoelectric effect is among the most investigated ways of electromechanical conversion in the field of vibrational energy conversion [1] – [2]. The piezoelectric micro generator consists of a piezoelement which acts as a generator. These generators are given the required mechanical stress using some sort of mechanical device. The piezoelement is connected to the electrical network. The electrical network consists of the energy receiver. Depending of the electromechanical coupling and the nature of the energy receiver, alternating voltage is generated on the piezoelectric element. Recent advancement in technology has increased the

demand of self powered devices which is capable of handling its own energy requirement. Also with wireless energy transfer concept coming in picture has increased the demand of small power generator capable of generating and holding the required amount of power by the device [4] – [5].

Piezoelectricity being a renewable energy concept, able to provide energy for low powered devices and having the ability of being used in lot of devices draws attention towards itself. Piezoelectric elements have a great potential of fulfilling the energy requirement ranging from a very small value to a very high value. Thus the focus has greatly sifted from generating energy from piezoelement to optimized power generation from the piezoelements.

The main problem with the piezoelement is that the power generated is not constant, conversion of energy is also low and the output power is load dependent. It has been discovered that the energy conversion of the piezoelement can be enhanced hundred folds by giving a nonlinear treatment to the piezoelectric voltage [6] – [7]. Also the power generated from the piezoelectric element is dependent on the load. Lot of concepts has been proposed to overcome these issues in power generation from piezoelements. Energy extraction from a standard circuit consisted of a universal diode bridge and a capacitor connected in parallel with the load. This circuit optimized the output power to some extent but the issue of the load dependence was present.

## II. METHODOLOGY

The approach used to overcome the problems of the energy extraction from the piezoelements is by using; (a) Proper smoothing capacitor in case of the standard circuit, and (b) DSSH technique. In the first case, the capacitor value is selected just before the electrical load such that the output is constant and has improved results in terms of voltage optimization.

The DSSH technique optimizes the electro- mechanical conversion. It also gives a fixed harvested energy irrespective of the load. This technique uses a capacitor as an intermediate energy storage stage. The intermediate stage stores some energy and passes the extra energy to the resonating inductor and finally to the load through the smoothing capacitor. This helps in the phase alignment of voltage and current. Also we get fixed output and the dead zone present in earlier models is removed. The only disadvantage of this technique is that we don't get pure DC output.

**Revised Manuscript Received on July 05, 2019.**

**Ravi Shekhar**, Assistant. Professor, Department of Electrical Engineering, Amity University Patna, India.

**Dr. Prakash Kumar**, Assistant. Professor, Department of Electrical Engineering, Amity University Patna, India



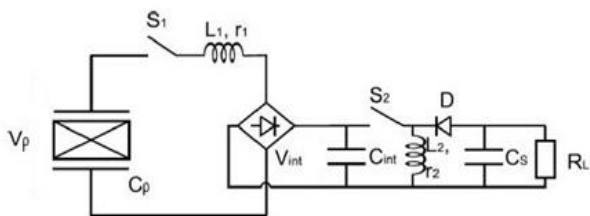

Figure 2.1 Single Switch harvesting model

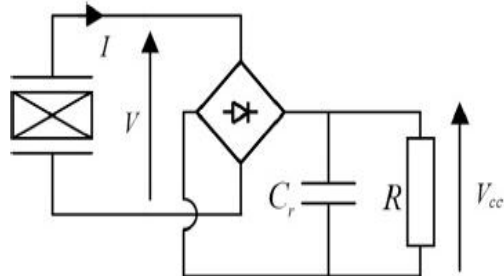

Figure 2.2 Standard Harvesting Device

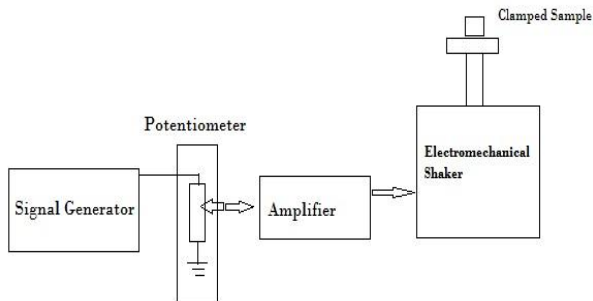
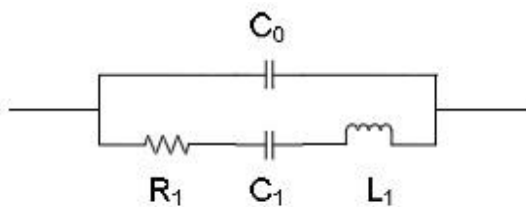

Figure 2.3 Experimental setup of the micro generator

The basic circuit, having a piezoelement, an uncontrolled bridge followed with a capacitor, is explained in paper. The capacitor value was not optimized in The previous paper. This issue has been rectified in the current work.



Electrical equivalent circuit

Figure 2.4 Electrical equivalent circuit

The modeling of the mechanical structure in different way was tested and the best model under different situation was proposed. It also throws some light on the basic harvesting circuits

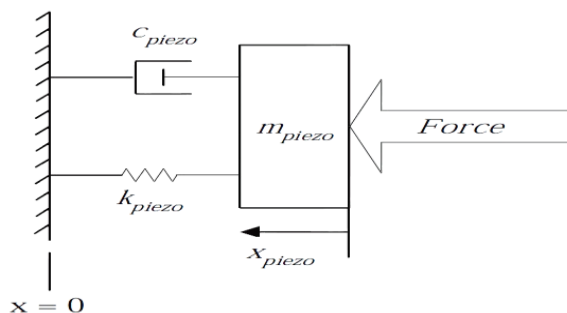

Figure 2.5 Mass Spring Model of Piezoelectric Generator

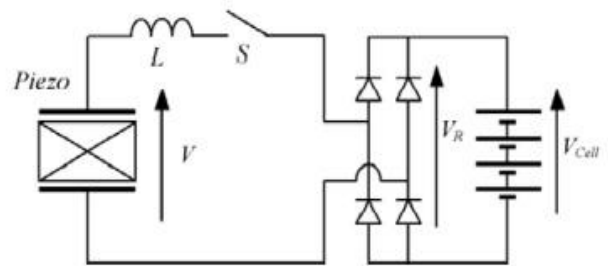

Figure 2.6 Synchronized switch harvesting over inducton

### III. OBJECTIVES

Once the methodology has been identified, the working module aims at achieving the following objectives in order to build an external circuit to enhance the efficiency of the piezotransducer further and at the same time reduced losses and optimal energy generation. Objectives include:

- Open circuit output voltage should be independent of the load attached (given that the load is resistive in nature).
- Power enhancement using intermediate stage of capacitor and inductor.
- Output current and voltage should be in phase with each other.
- Dead zone in the output power should be minimized/removed.

#### A. Piezoelectric Energy Extraction Circuits

Lot of concepts has been proposed for power generation from piezoelectric elements. Energy extraction from a standard circuit consists of a universal diode bridge and a capacitor connected in parallel with the load. It is the simplest circuit present in the market to extract energy from the piezoelement. It is generally designed for fixed load and as the load changes, the circuit has to be modified according to the load. This circuit optimizes the output power to some extent but the issue of the load dependence is present in this circuit. In particular, "SECE circuit" technique combines both the advantages of optimized output power and load independence of the power generated. The harvested energy in this circuit can be used for a very small range of load variation that too of a resistive nature. The problem with this concept is that the optimized power is not that high and at times, when the electro-mechanical coupling is not good, output power decreases drastically and became load dependent.

The approach used to overcome the problems of the energy extraction from the piezoelements is by using (a) Proper smoothing capacitor in case of the standard circuit, and (b) DSSH technique

In the first case, we select the capacitor value connected in parallel to the electrical load such that the output is constant and has improved results in terms of voltage optimization.



The DSSH technique optimizes the electromechanical conversion. It also gives a fixed harvested energy irrespective of the load. This technique uses a capacitor as an intermediate energy storage stage. The intermediate stage stores some energy and passes the extra energy to the resonating inductor and finally to the load through the smoothing capacitor. This helps in the phase alignment of voltage and current. Also we get fixed output and the dead zone present in earlier models is removed. The only disadvantage of this technique is that we don't get pure DC output.

**B. Dssh Circuit And Its Working**

This section aims at describing the double synchronized switch harvesting technique circuit elements and its working. The circuit is presented in figure 3.1.

It consists of a piezoelectric element, a series inductor having a small internal resistance, a diode bridge, an intermediate capacitor and an inductor. This inductor also has small internal resistance. The circuit also has a diode, a smoothing capacitor connected to the load. Two switches are present in the circuit. One switch is connected between the piezoelectric element and the uncontrolled bridge and the second between the intermediate capacitor and the inductor. The DSSH model is divided into two parts. The piezoelectric element in this circuit is represented by a current source attached in parallel to a capacitor. The values of the elements used are given in table 1.

Element	Value	Element	Value
Piezoelement Current $I_p$	1mA	Piezoelement Capacitor $C_p$	30nF
Piezoelement Voltage $V_p$	50V	Resonance Frequency	105.3 Hz
Inductor $L_1$	1H	Capacitor $C_{int}$	30nF
Inductor $L_2$	2H	Smoothing Capacitor $C_s$	1pF
Resistance $r_1$	50 ohm	Resistance $r_2$	10 ohm

Table 1: Values of the elements used in DSSH circuit

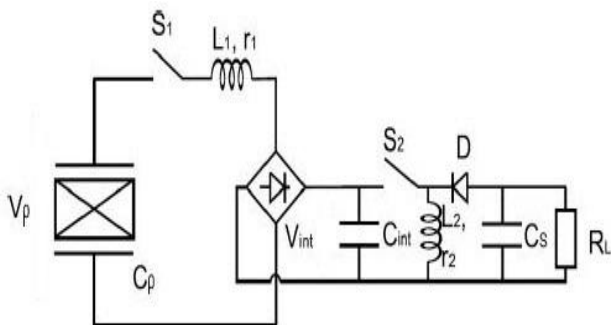

Figure 3.1 Double synchronized switch harvesting model

First part consists of the piezoelement, series inductor  $L_1$  having internal resistance  $r_1$  along with the uncontrolled bridge, switch  $S_1$  and the middle stage capacitor. The model till the capacitor is equivalent to the SSHI technique earlier proposed in papers [10], [11].

The next part of the circuit consists of the inductor  $L_2$  having internal resistance  $r_2$ , switch  $S_2$ , a diode to stop the reverse flowing of the charge along with the smoothing capacitor and load. Next the operation of the DSSH circuit is explained. For the majority of the time, the piezoelectric element is kept in open circuit form. When the voltage on the piezoelectric element reaches at the maximum point, the switch  $S_1$  is turned on. The time period for which this switch is closed is very small but enough for the capacitor to get charged to its maximum point. At this point energy is transferred to the capacitor from the piezoelement.

When maximum energy transfer is complete, the switch  $S_1$  is turned off and simultaneously the switch  $S_2$  is turned on. At this point, energy transfers from the capacitor to the inductor. When total energy is transferred to the inductor, the switch  $S_2$  opens and directly the diode conducts due to its natural nature.

When the diode conducts, energy is transferred to the smoothing capacitor and finally to the load. As all these processes get completed, the circuit starts operating for the initial operation.

All these energy operation process is so synchronized that the voltage at the load part is continuous and independent of the load attached, given that the load is resistive in nature.

**3.3. Mathematical Expressions For Dssh Circuit**

**A. When switch  $S_1$  is closed**

When the switch  $S_1$  is closed, piezoelectric element gets connected to the electrical resonant circuit. The current flowing through the closed loop circuit is calculated by the KVL equation given below

$$L_1 \ddot{q}_p + r_1 \dot{q}_p + \frac{q_p}{C_{equ}} = 0 \quad \dots(1)$$

Where,  $q_p$  is the charge on the piezoelectric element,  $L_1$  is the series inductor connected to the piezoelement and  $r_1$  is the internal resistance of inductor  $L_1$

$$C_{equ} = \frac{C_p C_{int}}{C_p + C_{int}} \quad \dots(2)$$

Where,  $C_{equ}$  is the equivalent capacitance of  $C_p$  and  $C_{int}$ ,  $C_p$  is equivalent piezoelectric capacitance and  $C_{int}$  is Intermediate capacitance of the external circuit.

Considering the piezoelectric element maximum voltage induced to its edges as  $V_p$  just before the switch  $S_1$  is turned on, the current flowing in the first part of the circuit is given by solving the 2nd order differential equation given in the equation (1) above



$$\dot{q}_p = -c_{equ} V_p \frac{\omega_0}{\sqrt{1-\delta_0^2}} e^{-\omega_0 \delta_0 t} \sin\left(\omega_0 \sqrt{1-\delta_0^2} t\right) \dots(3)$$

Where,  $\omega_0$  is the natural frequency given by

$$\omega_0 = \sqrt{\frac{1}{L_2 C_{equ}}} \dots(4)$$

and  $\delta_0$  is the damping coefficient given by

$$\delta_0 = \frac{1}{2} r_1 \sqrt{\frac{c_{equ}}{L_2}} \dots(5)$$

The switch S1 gets open when the current flow gets nil i.e the intermediate capacitor gets fully charged giving the amount of charge transfer. This is obtained by integrating equation (3) from 0 to  $\pi/\sqrt{1-\delta_0^2}$  given as

$$\Delta q_p = -c_{equ} (1 + \gamma_0) V_p \dots(6)$$

Where,  $\gamma_0$  is known as the inversion factor given by

$$\gamma_0 = e^{-\pi \delta_0 / \sqrt{1-\delta_0^2}} \dots(7)$$

The piezoelectric element voltage and the intermediate capacitor voltage changes due to this switching event and after the energy transfer process, the voltages are given by

$$\left(V_{c_p}\right)_{end} = V_p + \frac{\Delta q_p}{c_0} = \left[1 - \frac{c_{int}}{c_0 + c_{int}} (1 + \gamma_0)\right] V_p \dots(8)$$

$$\left(V_{c_{int}}\right)_{end} = \frac{\Delta q_p}{c_{int}} = \frac{c_0}{c_0 + c_{int}} (1 + \gamma_0) V_p \dots(9)$$

Thus the energy extracted during this switching period is given by

$$E_1 = \frac{1}{2} c_{int} \left(V_{c_{int}}\right)_{end}^2 \dots(10)$$

After this energy transfer process, switch S1 gets opened and the next energy transfer process starts from intermediate capacitor to the boost inductor.

### B. When switch S2 is closed

Once the switch S2 is closed, intermediate capacitor gets connected to the inductor.

The current flowing through the closed loop circuit is calculated by the KVL equation given below

$$L_2 \ddot{q}_{int} + r_2 \dot{q}_{int} + \frac{q_{int}}{c_{int}} = 0 \dots(11)$$

Where,  $q_{int}$  is the charge on the intermediate capacitor,  $L_2$  is the inductor connected between the two capacitors and  $r_2$  is the internal resistance of inductor  $L_2$

$C_{int}$  is the intermediate capacitance of the external circuit. The voltage on the intermediate capacitor is given by  $\left(V_{c_{int}}\right)_{end}$  just before the switching of S2, the current flowing

in the intermediate stage of the circuit is given by solving the 2<sup>nd</sup> order differential equation given in the equation (11) as

$$\dot{q}_{int} = -c_{int} \left(V_{c_{int}}\right)_{end} \frac{\omega_{int}}{\sqrt{1-\delta_{int}^2}} e^{-\omega_{int} \delta_{int} t} \sin\left(\omega_{int} \sqrt{1-\delta_{int}^2} t\right) \dots(12)$$

Where,  $\omega_{int}$  is the natural frequency given by

$$\omega_{int} = \sqrt{\frac{1}{L_2 C_{int}}} \dots(13)$$

And  $\delta_{int}$  is the damping coefficient given by

$$\delta_{int} = \frac{1}{2} r_2 \sqrt{\frac{c_{int}}{L_2}} \dots(14)$$

The switch S2 gets open when total charge is transferred from the capacitor to the inductor. The equation of the current at the end of this process is given by

$$\left(\dot{q}_{int}\right)_{end} = c_{int} \left(V_{c_{int}}\right)_{end} \omega_{int} e^{-\delta_{int} \pi/2} \dots(15)$$

After this the energy is transferred from the inductor to the smoothing capacitor and from smoothing capacitor to the load where the voltage is assumed to be more or less constant.

## IV. RESULT

### A. Result For Piezoelectric Transducer

This section discusses the output of the piezoelectric transducer electrical model. The model taken up in this project consists of an A.C current source in parallel with a capacitor. The output voltage of the piezoelectric transducer is 50 volts and the output current is 1 milli ampere. The current source is taken as 1milliampere and the capacitor value is taken as 30 Nano farad.

Figure 4.1 depicts the simulation model of the piezoelectric transducer and figure 4.2 depicts the output voltage and current waveform of the piezoelectric transducer.

Element	Value
Piezolement Current Ip	1mA
Piezolement Capacitor Cp	30nF
Output voltage Vp	50V
Output current I	1mA

Table 4.1 Input and output parameters of the piezolement



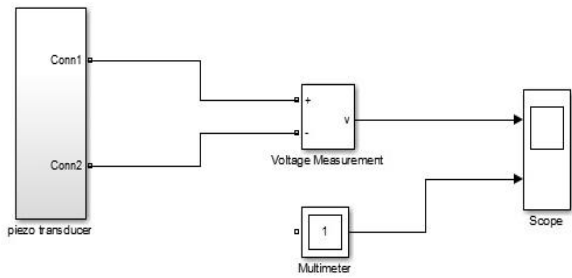

Figure 4.1 Piezoelectric transducer

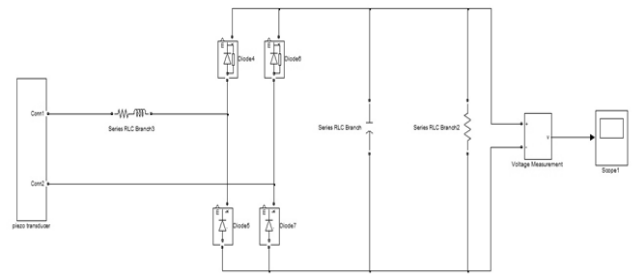

Figure 4.2 Simulation circuit of standard extraction circuit

**B. Result For Standard Extraction Circuit**

This section discusses about the standard extraction circuit and its waveform. The standard extraction circuit consists of a piezoelectric transducer model which is connected to the uncontrolled bridge followed by a smoothing capacitor and a resistive load.

The issue with this extraction circuit is that it is not continuous i.e there is a lot of dead zone area present in the output voltage waveform. Also the output is dependent on the load connected to the circuit.

Figure 4.3 shows the simulation waveform of the standard circuit and figure 4.4 shows the output of the circuit containing the dead zone.

**C. Result For Synchronized Switch Harvesting Over Inductor Extraction Circuit**

In this section, a further modification of the standard circuit is done by adding an inductor in series with the piezoelectric element. The addition of the inductor boosts the output voltage at the load. But a drawback of the inductor is suffered. The inductor makes the waveform to pulsate which further bring in the requirement of a battery where the energy can be stored before being used in any application.

Figure 4.3 shows the simulation circuit and Figure 4.4 shows the waveform of the simulation circuit.

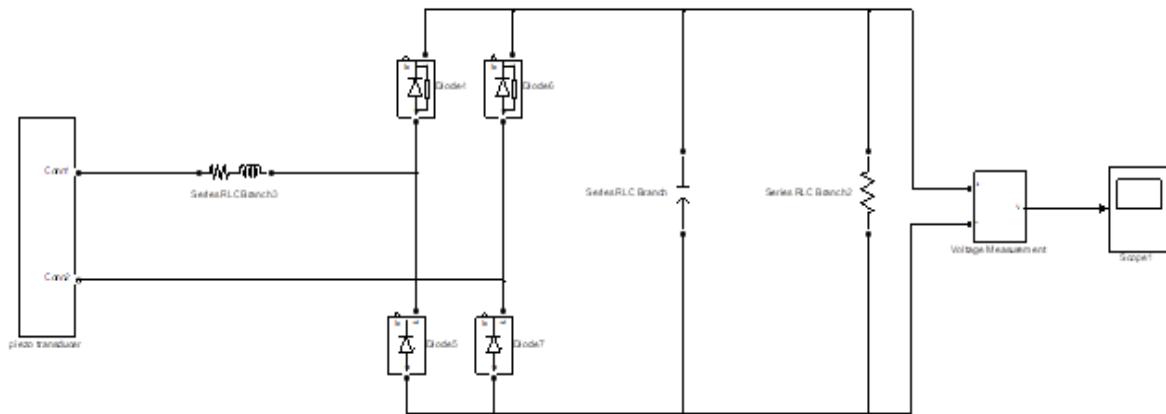

Figure 4.3 Synchronized switch harvesting over inductor

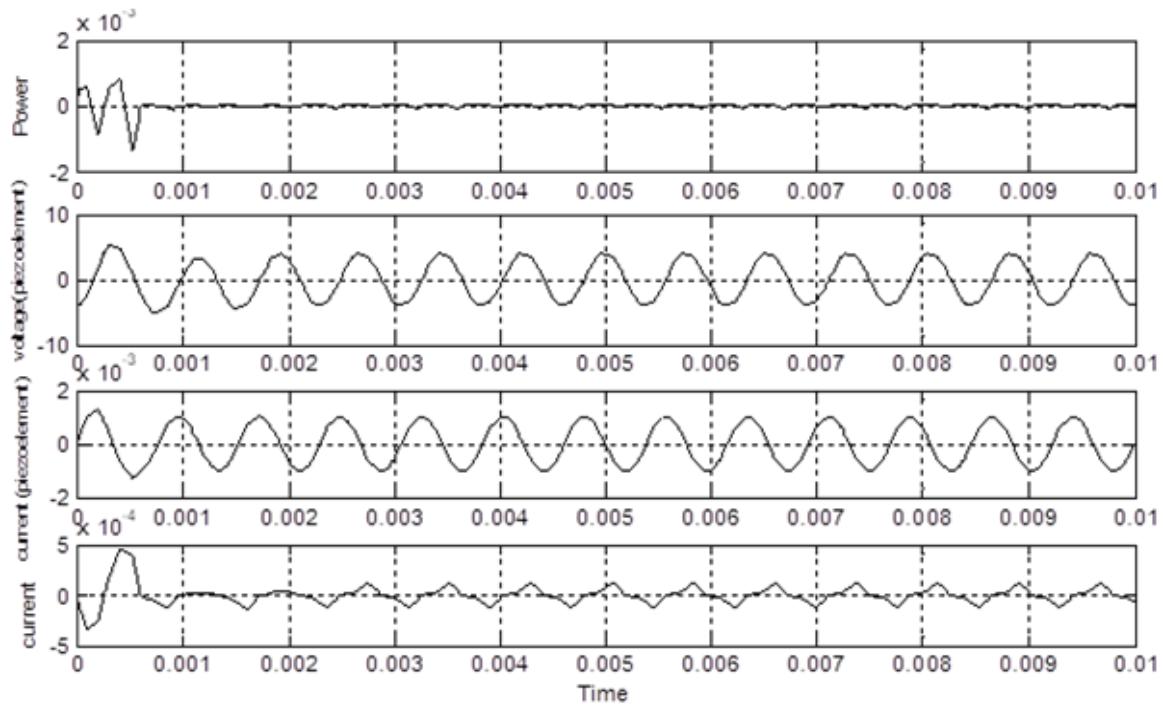

Figure 4.4 Waveform of SSHI circuit

**D. Result For Double Synchronized Switch Harvesting Technique**

This section deals with the final circuit implemented for extraction of energy from the piezoelectric element. This circuit is implemented in two parts: (a) DSSH circuit without any switch, and (b) DSSH circuit with both the switch active with different duty cycle.

The first circuit is shown in figure 4.11. This circuit has an intermediate capacitor and an inductor but there is no switch attached between them for optimal flow of the energy. The waveform shown in figure 4.12 is discontinuous with optimized power. The dead zone is not a satisfactory condition, so switches are attached to remove this dead zone. In figure 4.6, the advanced DSSH circuit is shown where the switches are attached between the piezoelectric element and the capacitor and between the capacitor and the inductor present in the intermediate stage. The two outputs of this circuit are shown in figure 4.7 and figure 4.8

The first waveform has some dead zone due to the small charging time given to the capacitor which could not store enough energy to support the circuit when the piezoelement is not connected to the external circuit.

The next waveform shown in figure 4.8 overcomes this drawback. This is achieved by increasing the duty cycle of the first switch between the piezoelectric element and the capacitor. By doing this, the capacitor gets enough energy stored in it to support the further process when the piezoelement is not connected.

**E. Losses Calculation And Gain Of Dssh Circuit Over Standard Circuit**

Input from piezoelectric element to the extraction circuits

The input voltage and current as obtained from waveforms of simulation are taken into consideration for input power calculation as follows:

Input voltage  $V_I = 50V$

Input current  $I_I = 1mA$

Input power  $P_i = V_I I_I$

$P_i = 50 \times 0.001$

$P_i = 50mW$

Output of Standard Circuit

The output voltage and current as obtained from waveforms of simulation are taken into consideration for output power calculation as follows

Output voltage  $V_O = 0.2V$

Output current  $I_O = 1mA$

Output power  $P_O = 0.2 \times 0.001 = 0.2mW$

Output of Optimized Standard Circuit

The output voltage and current as obtained from waveforms of simulation are taken into consideration for output power calculation as follows

Output voltage  $V_O = 0.5V$

Output current  $I_O = 1mA$

Output power  $P_O = 0.5 \times 0.001 = 0.5mW$

Output of DSSH circuit

The output voltage and current as obtained from waveforms of simulation are taken into consideration for output power calculation as follows

Output voltage  $V_O = 0.8V$

Output current  $I_O = 1mA$

Output power  $P_O = 0.8 \times 0.001 = 0.8mW$

Losses in Standard circuit

Losses =  $P_i - P_O = 50 - 0.2 =$

$48.8mW$



Losses in Optimized Standard circuit

$$\text{Losses} = P_i - P_o = 50 - 0.5 = 48.5\text{mW}$$

Losses in DSSH circuit

$$\text{Losses} = P_i - P_o = 50 - 0.8 = 48.2\text{mW}$$

Gain of the DSSH circuit over standard circuit in terms of output power

$$P_{out} = \frac{0.8}{0.2} \times 100$$

Discrete,  
 Ts = 5e-005 s,  
 powergui

Gain = 400%

These above calculations give the gain of the DSSH circuit over the standard circuit. We can see that the gain improvement is 400%. Also we see that the loss in the DSSH circuit is minimum.

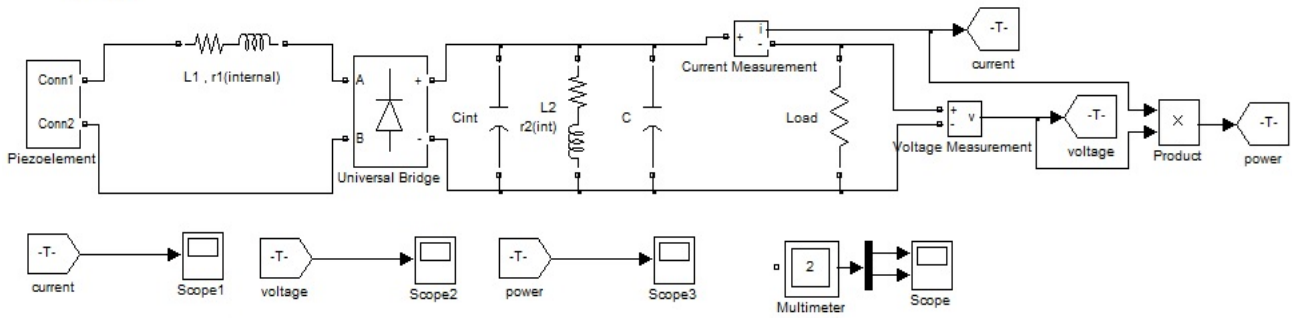

Figure 4.5 Dssh circuit

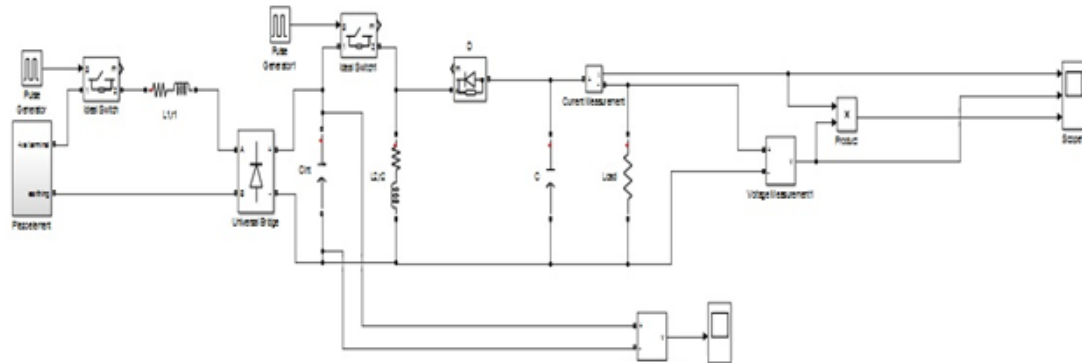

Figure 4.6 Dssh circuit with 2% duty cycle

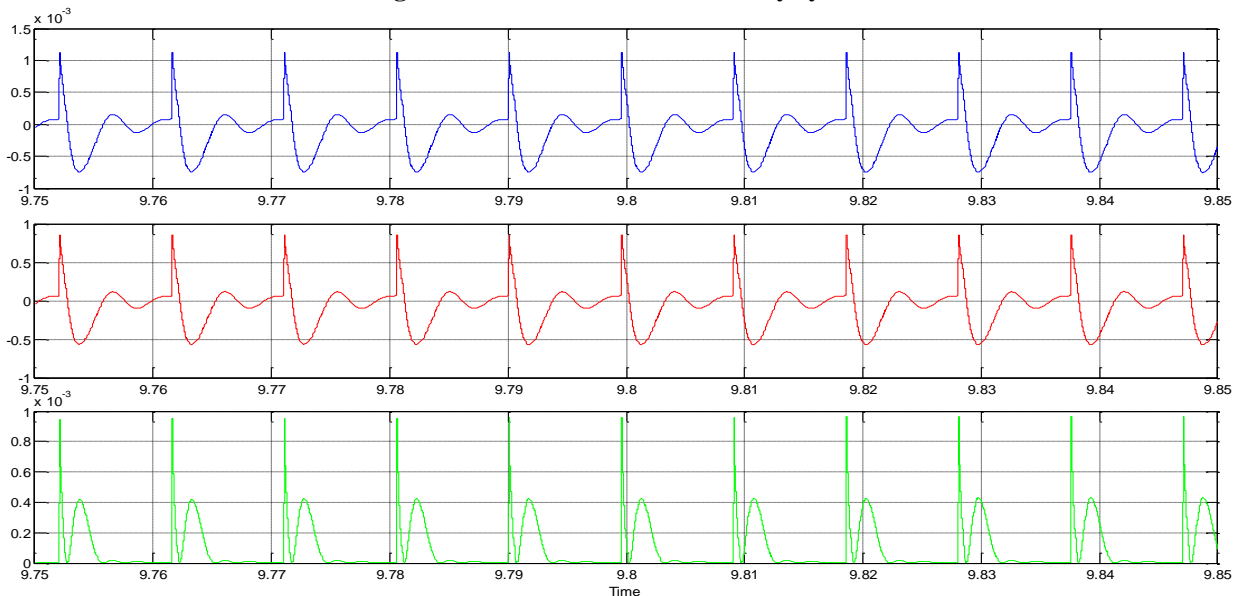

Figure 4.7 Output current, voltage and power with dead zone

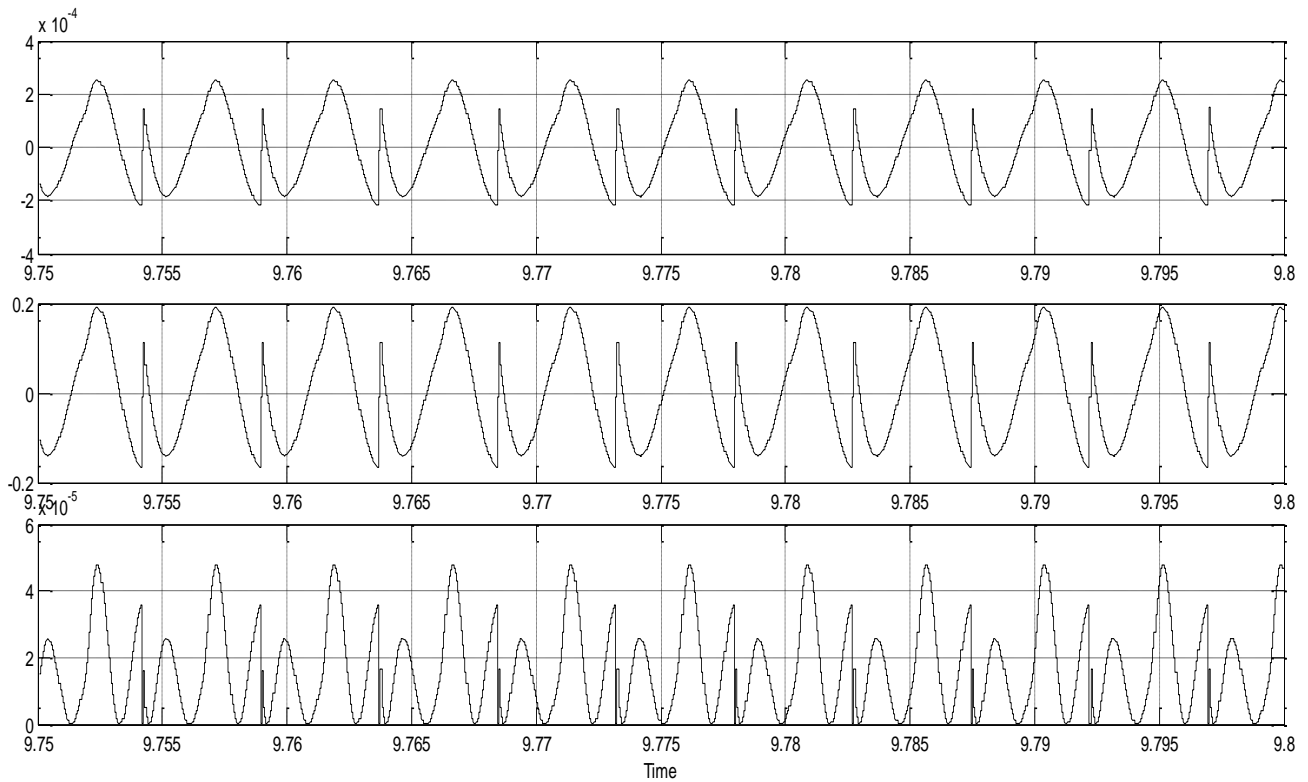

Figure 4.8 Output current, voltage and power without dead zone

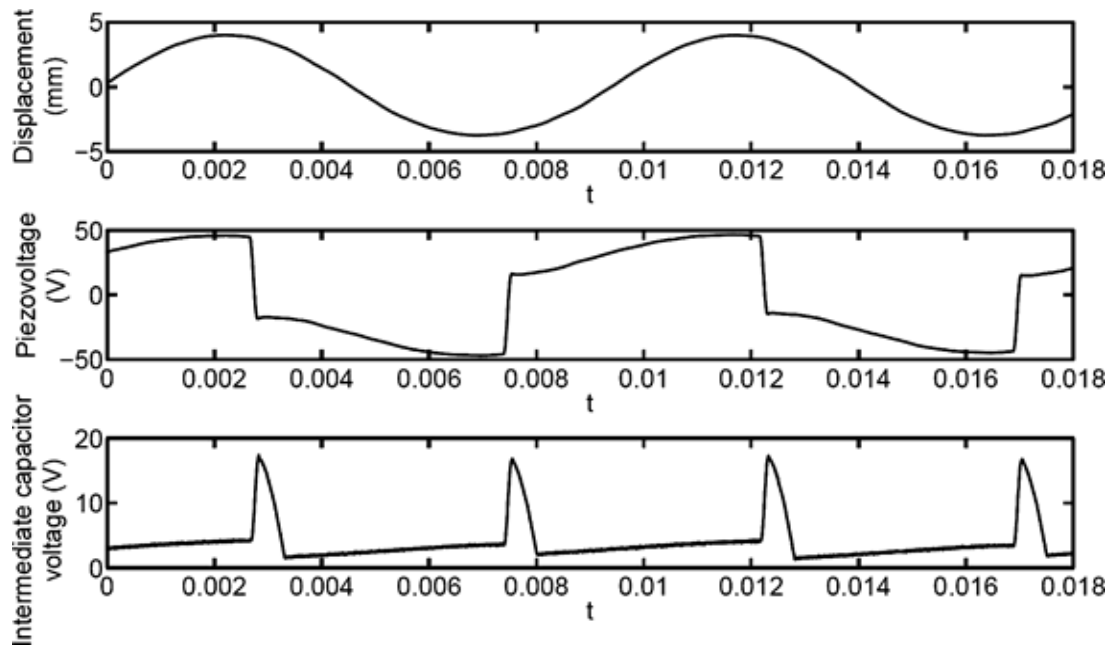

Figure 4.9 Output piezo voltage and Displacement

V. CONCLUSION

This section aims at summarizing the whole work done during this preparation of this paper and pointing out at some of the future work. The main aim is the enhancement of the efficiency of the external circuit. Along with it, the open circuit load voltage has been improved by adjusting the value of the smoothing capacitor appropriately. A new concept, double synchronized switch harvesting technique is

implemented which greatly improves the output characteristics of the external extraction circuit. This technique brings the load current and voltage in phase in spite of the capacitor and inductor present in the circuit. In phasing of the current and voltage is achieved by turning on the piezoelectric switch at the point of maximum voltage across the piezoelement.



Also the open circuit load voltage is made independent of the load attached but only till the load is resistive in nature. A very big issue of the dead zone present in earlier extraction circuits has been removed in the DSSH technique. With all these advancement, the losses in the circuit is automatically reduced.

## VI. FUTURE WORK

There are still some areas which require improvement. Those areas can be taken up for future research.

The output waveforms can be further improved. Also for the technique to be fully implemented, a buck – boost stage can be introduced in the circuit. Again work can be done in reducing the size of the external circuit as two switches require synchronized switching which leads to a complex circuit.

## REFERENCES

1. C. N. Xu, M. Akiyama, K. Nonaka and T. Watanabe, "Electrical power generation characteristics of PZT piezoelectric ceramics," IEEE Trans. Ultrason. Ferroelectr. Freq. Control, vol. 45, no. 4, pp. 1065 – 1070, 1998.
2. P. K. Glynne-Jones, S. P. Beeby and N. M. White, "Towards a piezoelectric vibration-powered microgenerator," IEE Proc. Sci. Meas. Technol., vol. 148, no. 2, pp. 68 – 72, 2001.
3. Jina Kim, Benjamin L. Grisso, Jeong K. Kim, Dong Sam Ha, and Daniel J. Inman, "Electrical Modeling of Piezoelectric Ceramics for Analysis and Evaluation of Sensory Systems," SAS 2008 – IEEE Sensors Applications Symposium Atlanta, GA, pp. 122 – 127, February 12-14, 2008
4. J. Krikke, "Sunrise for energy harvesting products," IEEE Pervasive Comput., vol. 4, no. 1, pp. 4 – 5, 2005.
5. J. A. Paradiso and T. Starmer, "Energy scavenging for mobile and wireless electronics," IEEE Pervasive Comput., vol. 4, no. 1, pp. 18 – 27, 2005.
6. Badel, A. Benayad, E. Lefeuvre, L. Lebrun, C. Richard and D. Guyomar, "Single crystals and nonlinear process for outstanding vibration powered electrical generators," IEEE Trans. Ultrason. Ferroelectr. Freq. Control, vol. 53, no. 4, pp. 673 – 684, 2006.
7. Koeneman, P. B., Busch-Vishniac, H. J. and Wood K. L., "Feasibility of micro power supplies for MEMES," J. Microelectromech. Syst., vol. 6, no. 4, pp. 355 – 362, 1997.
8. R. Amirtharajah and A. P. Chandrakasan, "Self powered signal processing using vibration-based power generation", IEEE J. Solid-State Circuits, vol. 33, no. 5, pp. 687 – 695, 1998.
9. E. Lefeuvre, A. Badel, C. Richard, L. Petit and D. Guyomar, "A comparison between several vibration – powered piezoelectric generators for standalone systems", Sens. Actuators A, vol. 126, no. 2, pp. 405 – 416, 2006.
10. G. W. Taylor, J. R. Burns, S. M. Karmmann, W. B. Powers and T. R. Welsh, "The energy harvesting cel: A small subsurface ocean/river power generator", IEEE J. Oceanic Eng., vol. 26, no. 4, pp. 539 – 547, 2001.

## AUTHORS PROFILE



**Ravi Shekhar** received the Bachelor in Engineering (first class) in electrical and electronic engineering from Rajiv Gandhi Technical Univ., Bhopal, India, and the Master in Technology (first class with Honors) in Power Electronics from SRK University, India. His current research interests are dc-dc converters, electro thermal device simulation and investigation of power device reliability, electric vehicle and drives.

He is currently working as assistant professor Amity School of Engineering & Technology in Amity University Patna.



Dr. Prakash Kumar received the B.E. & M.Tech (Electrical Engineering) in year 2008 and 2012; and Ph.D. from Rajasthan Technical University Kota, India, in 2017. His research interest includes power converters, controllers, renewable distributed & integrated generation, electro thermal applications, etc. He is currently working as assistant professor Amity School of Engineering & Technology in Amity University Patna.