

Dynamic Monitoring Of Agricultural Cultivation using IoT and Cloud Mechanism

B. Balaji Bhanu, Mohammed Ali Husain, Ande Prasad

Abstract: The objective of this work is a dynamic monitoring of agricultural cultivation using WSN technology. The Wireless Sensor nodes are designed in controlling and supervising the factors of variegated of such as level of water, humidity, and temperature. ZigBee mechanism is used as a medium of transmission in WSN (Wireless Sensor Network) devices using sensors, routers which propagate the data to longer distance over a network, with the help of coordinator sensor and will transmit the data to the cloud computer, which in turn will illustrate the control and data in the monitoring system. The node sensor will extract the factors of agriculture from various sources on real-time and will transmit the data using IoT (Internet of Things), which is integrated with one another on various platforms for performing various types of actions and will reduce the need of labor. Apart from monitoring, enhancement of details can be proposed based on WSN for the deployment of various nodes and by applying digital acquisition strategies for acquisition of data and performing various types of data analysis on cloud using the collected information of agriculture.

Keywords : WSN, ZigBee, Networks, Sensors, Agriculture.

I. INTRODUCTION

WSN's are collection of sensor nodes which are connected using sensors and actuators and are distributed spatially and autonomous used for physically monitoring the physical parameters like temperature, pressure, humidity etc. Then the data is passed on to the next network. Many of the present networks are in duplex mode, having the capability of controlling the sensor activity. Utility of IoT solutions suitable for the sectors like agriculture, environment are required for continuous monitoring and controlling of many parameters. Whereas IoT opens new opportunities beyond the automation when the collected data is used to feed machine learning algorithms to provide predictions ease off decision plan and decision making for farmers. The WSN is built of "nodes" – each sensor network contains a power source which drives the microcontroller,

a trans receiver and different peripherals. Each sensor node is tiny in size so that it cost is variable on the basis of a size.. The performance of a node depends on the size of a memory, energy consumption, bandwidth of the data transmission and computational speed. The topology used in WSN may be a star network or a multi-hop mesh network. The propagation among the networks is flooding or routing. Figure1 depicts typical WSN architecture for Agriculture.

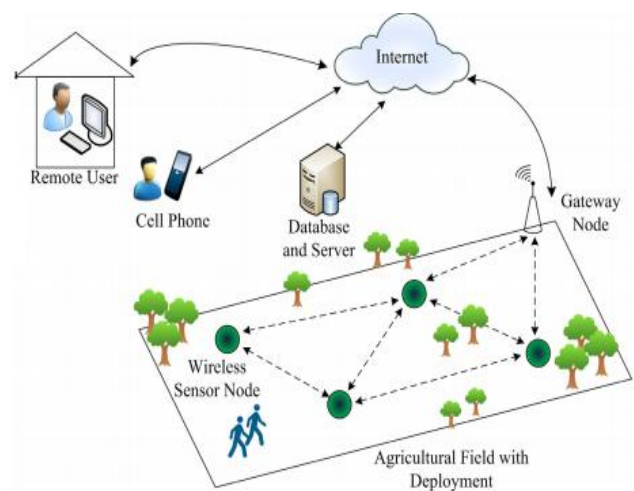

Figure 1: Typical WSN Architecture for Agriculture

Agriculture field contains a cluster of sensor nodes and a single gateway sensor node. This node arranged in a simple star network or in advanced multi-hop wireless mesh network. The data propagation among the nodes is passed to the internet via a gateway node [1].

ZigBee is an IEEE 802.15.4 -is a wireless technology meant for a high-level communication protocol used to create personal area networks with low-power digital radios. The ZigBee is simpler and in-expensive compared to other wireless personal area networks (WPANs), such as Bluetooth or Wi-Fi. ZigBee supports three types of topologies which are shown in Figure 2. [2]

The network layer of ZigBee supports both the tree and star topology networks, with a generic mesh topology. In a star network, the coordinator is the central node. Both the tree and mesh allow the use of ZigBee routers for the extension of communication at the network level.

Revised Manuscript Received on July 05, 2019

B. Balaji Bhanu, Research Scholar in CSE, SCSVMV University, Kanchipuram, Tamilnadu, India

Mohammed Ali Husain, Professor, Department of ECM, KL to be University, Vaddeswaram, Guntur Dist., AP, India

Ande Prasad, Head Dept. of Computer Science, Vikrama Simhapuri University, Nellore, AP, India

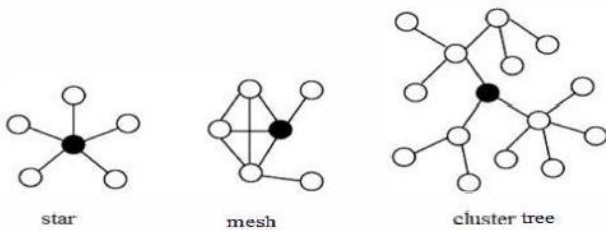

Figure 2: ZigBee topologies

II. IRELATED WORK

WSN uses ZigBee technology which is basically used in remote sensing domains of civilian and industrial. Later, there was a shift and an interest in managing water resources and monitoring agricultural reforms. Sensors are interfaced with Raspberry Pi for Smart Agriculture which is one of the essential applications of IoT. This helps in reducing the wastage of water, fertilizers to improve the yield of a crop. This system is not incorporated for measuring the pH value. So that correct usage of fertilizers is not known [3].

Raspberry pi and sensors improve the efficiency of the agriculture. Using IoT all the details are stored in the cloud and can be monitored. Data is processed in a smart cloud service [4]. The developed multimedia platform can be controlled remotely by a mobile phone. It uses LoRa WAN network protocol which provides a long distance communication with very low energy consumption. Farmers used to observe the complete cycle from seeding to harvesting with the help of a IoT based agriculture production. Irrigation controllers operate at the 868MHZ ISM frequency as LoRa WAN or Sigfox. This system access the plant health by a simple application through the phone. Main advantages are more efficient and accurate information is fetched, reduced man power and Electrical Energy was saved.

Different types of actuators such as sprinklers, humidifiers, lamps, etc. were widely used in irrigation, fertilization, pesticide management, and illumination control [5]. Studies provide a simple solutions proposed for agro-industrial and environmental problems.

A low cost and low power IoT network designed by Soumil Heble et. al. for smart agriculture [6]. An in built house IITH mote was used as a sink and sensor node with solar powered features. Power line problems were solved by LoRa based gateway.

Problem of efficient learning from a limited training set becomes very important. Support vector machines (SVM) are a recent approach to classification address the issue within the framework of statistical learning theory. It implements classifiers of an adjustable flexibility, which is automatically in a principled way, optimized on the training data for a good generalization performance. The approach is introduced and its learning behavior is examined [7].

A fuzzy decision support system for irrigation and water conservation in agriculture [8] improves an existing irrigation web services. This System improves the irrigation, and the crop site characteristics information.

III. PROPOSED MONITORING SYSTEM DESIGN

The dynamic monitoring of agricultural cultivation system with wireless sensor networks is deployed in an agricultural site. Low power sensor network measures different parameters through wireless sensor nodes equipped with corresponding sensors. Collected data by the sensors is sent to the base station. Then the base station will analyze the received data. Figure 3 shows the basic topology of monitoring system used for the implementation [9].

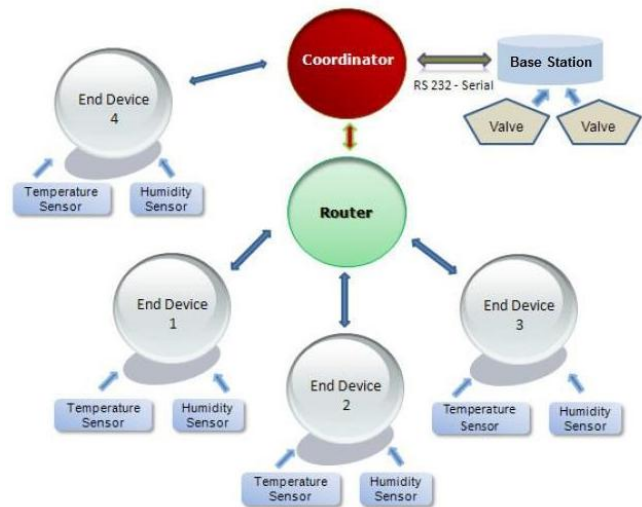

Figure 3: The basic topology of monitoring system

The coordinator communicates with the base station through serial communication RS232. The base station in turn analyzes and stores the incoming data from the nodes. Then it manages the control signals that regulate the sensors' sampling rate. Knowledge of the precise time is important so as the base station to be able to check for the on-time arrival of all the packets, through the coordinator. The router extends the range of the wireless network while end-devices can be connected directly to the coordinator or to a router. The end devices, which are scattered in the field, contain various sensors. The most important characteristic of the network is the bi-directional communication with ZigBee technology [10].

A. Hardware

A portable end-device was designed and developed consisting of different sensors, a microcontroller with a ZigBee module. Architecture of End-device is shown in Figure 4.

Dynamic Monitoring Of Agricultural Cultivation using IoT and Cloud Mechanism

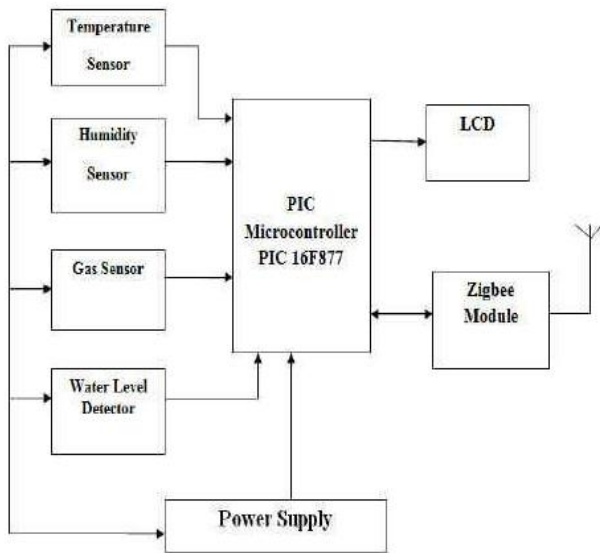

Figure 4: Architecture of End-device

Humidity related sensor is mainly based on electrodes which are embedded with gypsum block, its aim is to simplify with low cost efficiency. The module of ZigBee used in our experiment is of Texas instrument named eZ430-RF2480. It is a complete tool of wireless development, which includes MSP430 a power ultra microcontroller with a very low and a power full transceiver CC2480 with 2.4GHz.

The circuit designed consists of humidity sensor included a Bridge oscillator which is followed with a peak-detector and Non Inverted amplifier within a gain adjustable offset DC which is shown below in figure 5.

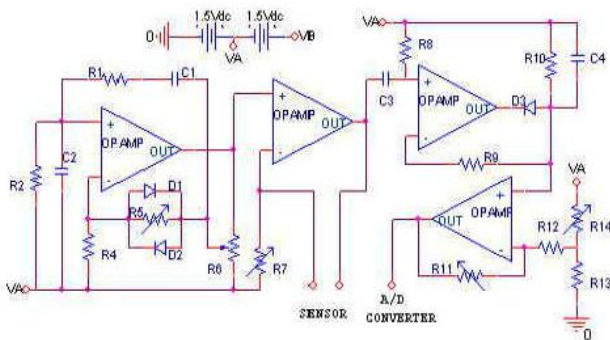

Figure 5: Circuit of humidity sensor

The voltage gain at the second op-amp will depend on the R7 resistor value; it will control the supplied current of the sensor with that of humidity sensor resistance. As there is decrease in the resistance of sensor value, we can see the increase of ground humidity were the result output will swing at the amplifier output [11]. The DC voltage generated by the peak detector is based on the negative peak of the signal while the non-inverting amplifier that follows can be adjusted to give an output of 0-2V of the humidity level.

B. Software

Monitoring system software is divided into three parts: coordinator approach, end-device approach and computer analysis approach is illustrated in Figure 6.

C. Transmitter flow

nodes on the electrical activation
initialize SHT11 and collect data
initializes CC2530
findzig-Bee network
find the network
SHT11 send data
CC2530 receive data
send data to the receiver

D. Receiver flow

power on reset
initialize CC2530
initializeZig-bee wireless network
answer , request to join and assign the address
wait for transmitter to send data
whether receiver is receiving the data
receive each transmitting end data
transfer data to the host

In relate to the wireless network requirement in implementing and to implement a low-cost, low-power consumption with high sensitivity and high performance In this paper, we choose CC2430 chip from TI company for ZigBee nodes , SHT15 chip for sensors, and the power with solar panels. In this work , we selected a Chip CC2430 of T1 company of node type ZigBee, sensor of chip SHT15, solar power adopter part for power management initially 1) S3C2440 Intelligent ARM which uses S3C2440 Samsung processor with a controller of main, used for frequency and high performance monitoring the real time video capture related application and processing it[12].

1) In Linux based operating system and Web based embedded boa server which runs and manages the controller of various types of equipments that includes network sensor, GPRS/GSM module of dual band, camera and USB as so on [13].

2) SHT15 sensor temperature is a multi-function , calibration , small size, sensor of intelligent, which has a parameter of relative measure such as humidity , temperature and measuring range of temperature which ranges from 400C ~ 123.80 C, having a 0.1 resolution, with a time response less than 3s. The intelligent SHT15 a new sensor with free debugging and calibration and has an almost no circuit outlet [14].

This system uses an RISC 32-bit processor of S3C2440 Samsung type with different types of peripherals and features in it. It's is based on core ARM920T with the support of WinCE, Embedded Linux, VX works and other operating systems of embedded. It also requires the properties of remote monitoring systems in managing the required data from the sensors [15].

3) Humidity-Sensor: This instrument will measure the

quantity of pressure, temperature, mass of electrical or mechanical changes in physical quantity based on substance and moisture absorbed. It calibrates and calculates the quantities of measurement that leads in finding the humidity measure of the soil, temperature and weather.

4) Sensor Soil: the sensor of soil will collect the information of soil related to moisture and temperature in an out-door environment. The Zig-Bee protocol communicates and realizes the frequency of digital part with a wide spread spectrum using technology of DSSS, which not only realizes for easy communication with a short-range of WSN communication of 802.15.4 of a compatible, with an improved wireless communication reliability. The stack protocol designed with reliable and precise that includes AES an important technology processor with CA/CSMA technology used for saving energy with in a network and its components, etc.

As and now in the past of energy low consumption based on components used within the circuit design, we used a network of star topology that reduces the failure of network structure with a relative failure in cluster nodes. This scope of topology will prevent the uses of less power by using battery of lithium power which can be supplied with a short and a very low amount of power consumption can be shorted for continuity, which makes the use of additional topology tree with a bigger free physical structure in managing the number of nodes or more[16].

We propose a power of solar supply, layer between internal protocols, information realize communication with an API through, 802.15.4 a protocol stack is provided for data service management.

In Executive direct function, the operational code is executed directly with a MAC code realize ; using certain functional access like date of which parametric function which relates to all the API MAC environmental function at the level of implementation.

Initially, the window GUI environment measure will illustrate the initializing parameters as follows: it uses coordinator in serial communication.

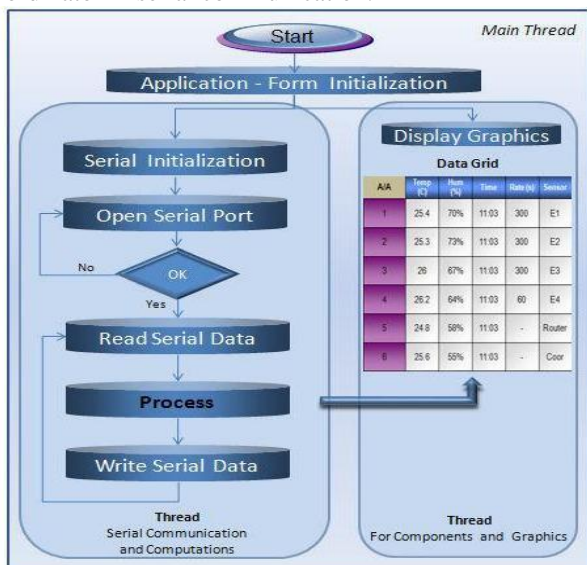

Figure 6: Block diagram of computer analysis algorithm
Processing of data as and when it receives data from serial communication device is send to the coordinate after processing the data. The added advantage of this code is that it has the concept of multi-threading method. i.e. each

of the threads can be used for gathering various types of data from various devices i.e. one thread is used for display the data, another for processing the data on serial communication device. Each of the threads gathered information is send to the co-coordinator, which uses a centralized thread in communicating the information with each other[17]. The GUI is mainly used for processing and engaging the data flow which is utilized by the main method which is developed to utilize the appropriate power of computer.

Data analysis and Data Acquisition is used for characterizing the data and converted into a digital agriculture data-climate truck, which is used for economic development and manipulation of data in various ways, it is based on the Zig-Bee principle of networking, the processor of data acquisition in digital agricultural should be of linear structure, structure of planar network or network space structure.

Linear Structure of Network is a simplified network structure used in green-house rectangular for data acquisition in digital agricultural. The network as a whole is a single path, which determines the number of nodes that are equal to the hop and belong to layers of network

Planar Structure of Network which are related to farmland of large scale, complex in pasture, due to network of multi-path; which has a very complicated scanning analysis time, our work includes square round instead of brief analysis.

Network Structure of Space is very much complex, which is conceivable to N-storey orchard, each of the storey's has blocks n related to each node of terrace.

In data analysis process which is used for data collection and monitoring the data in a system, which includes as follows : in network structure of linear, a slip of single network of linear type has a max nod capacity of 76 in that of 20s per scanning cycle, and also minimizes the hops in monitoring the capacity of the network. The network structure of planar type has intermediate node which should be fixed at certain location of topology which ever may be possible of centric topology type, the nodes which are far away from the centric node take much time in scanning the data of larger period, the size of structure as a whole has been recreated for structure of planer type, the node which is centralized should have a set of center topology network which is quite possible in central management, the nodes which are more closer to the edge takes time of scanning longer compared to the nodes that are near to the co-ordinate, which has a limit of scanning time, the entire capacity of network will be viewed as much smaller. In case of structured network space, the performance of the system in this is related to layers of each node number, for increasing the capacity of the network, each of the layered node has been limited.

IV. RESULTS

The reliability of the network has been formed based on the network nodes which are in various places based on inter-connected using topology mesh. The output generated can be visualized in the coordinating system of the computer which is



Dynamic Monitoring Of Agricultural Cultivation using IoT and Cloud Mechanism

connected evenly. In figure 6, we show that the nodes address represents route and coordinator details. i.e. it is the address of network and Zig-Bee address.



Role	MAC	Network Address
 Coordinator	0013A20040A62AC5	0000
 Router	0013A20040E8314A	838F
 Router	0013A20040E8312F	B5CA

Figure 8: MAC address of Roles

SI No.	Humidity	Temperature	Moisture	Light intensity
1	25.00	32.00	1023	654

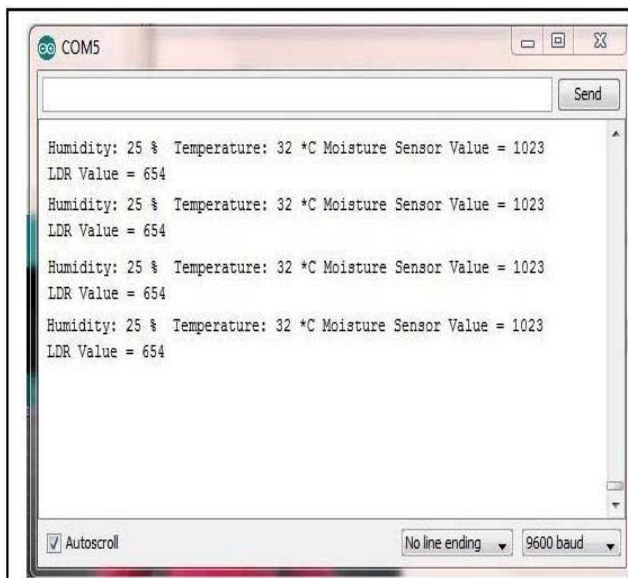

Figure 9: Parameters values

V. CONCLUSIONS

The proposed monitoring system can be used in proliferating the flourishing and growth of crops cultivation. This is possible by using surveillance based on environmental factors as well as the factors of crop growing in farm and the necessary steps for flourishing the crops growth. Zig-Bee type of monitoring system is proposed which is effective and reliable to monitor the conditions of environment. This paper proposes ZigBee based WSN which includes a valid data transmission from each node to the base station. Based on the data transmitted environmental data is monitored and observed based on the conditions. At the point of time, nodes of the network use a

strategy for deployment and are an important factor in process the agricultural data of acquisition from the topological network.

We conclude that the network topological structure which is designed will reduce the load of work and will optimize the network installation and provides flexibility in the network.

REFERENCES

1. Jose A. Gutierrez et. al., "Low-Rate Wireless Personal Area Networks: enabling wireless sensors with IEEE 802.15.4", IEEE, ISBN: 978-0-738-16285-0, (2011), 114-121
2. Shining Li et. al., "Wireless Sensor network for precise agriculture monitoring Intelligent Computation Technology and Automation", ICICTA, (2011) 87-92
3. T. Vineela et. al., "IoT Based Agriculture Monitoring and Smart Irrigation System Using Raspberry Pi", IRJET, 05 (2018) 1417-1420
4. Athira P. Shaji, "Raspberry pi based real time monitoring of Agriculture & Irrigation Using IoT", IJEDR, 6 (2018) 652 -656
5. Jesús Martín Talavera et. al., "Review of IoT applications in agro-industrial and environmental fields", Computers and Electronics in Agriculture 142 (2017) 283-297
6. Soumil Heble et. al., "A low power IoT network for smart Agriculture", IEEE 4th WF-IoT, (2018) 609-613.
7. Monica and Ajay K Sharma. "Comparative Study of Energy Consumption for Wireless Networks based on Random and Grid Deployment Strategies", International Journal of Computer Applications, 6 (2010) 25-28.
8. XiangYang et. al., "Random Deployment of wireless sensor Networks: Power of Second chance" ACM Press, 262-273
9. A. Willig and H. Karl, "Protocols and the Architectures for Wireless Sensor Networks", John Wiley and Sons Ltd, England, (2005) 35-39.
10. B. BalajiBhanu et. al., "Agriculture Field Monitoring and Analysis using Wireless Sensor Networks for improving Crop Production", IEEE, doi:10.1109/WOCN(2014).
11. Jianfa Xia et. al., Li, "An environment monitoring for precise agriculture, based on wireless sensors network", IEEE (2011) 55-59
12. Rekha P et. al., "Integrated Wireless Sensor Network for Smart Sesame Farming in India", Elsevier, (2012) 3-9
13. Awati J. S, Patil V. S, "Automatic Irrigation Control by using wireless sensor networks", Journal of Exclusive Management Science, 1(2012) 22-34
14. Laith Ali Abdul-Rahaim, Ahmed Mohammed Ali, "Remote Wireless Automation and Monitoring of Large Farm using wireless sensors networks and Internet", IJCSET, (2015) 57-64
15. Lopez RJA et. al., "Wireless Sensor Networks for precision horticulture in Southern Spain", Computer Electronics Agriculture, 68: 25-35.
16. MahirDursun and SemihOzden, "A wireless application of drip irrigation automation supported by soil moisture sensors", Scientific Research and Essays 6(2011) 1573-1582.
17. Aniket Hade, Dr. M.K. Sengupta, "Automatic Control of Drip Irrigation System& Monitoring of Soil by Wireless", IOSR-JAVS, (2014) 57-61