

# Physical Properties of Lead Arsenate Glass System

Y. Saritha Kumari, B. Krishna Kumari, Y. David Kumar

**Abstract:** My Present work is lead arsenate composite material ions, study the properties of the pbo As<sub>2</sub>O<sub>3</sub> glass system doped with Transition metal ions, scanning electron micro copy, EDS, X-RD and Optical absorption peaks readings wave length range is 300-1200 nm for identification of various electronic transitions metal ions. Lead Arsenate pure glasses doped with various composites of iron ions were preserved. study the samples characterized by XRD studies and SEM studies reveal the existence of (Fe<sub>2</sub>Pb)As<sub>2</sub>O<sub>6</sub> glassy points are also detected. The optical absorption bands of this glass have presented 3 absorption peaks on 670, 560 nm. the observed gradually growth trendy the strength of the peaks due to Fe<sup>+2</sup> transition ions at the expenditure of the peaks due to Fe<sup>+3</sup> transition ions up to 0.6 mol% .the amorphous Fe<sub>2</sub>O<sub>3</sub> glasses in the range of frequency 10<sup>2</sup> Hz to 10<sup>5</sup> Hz and temperature is 77 k to 450 k.

**Keywords:** Glass Preparations, SEM, EDS, XRD and Optical absorption

## I. INTRODUCTION

The metal ions like iron melted in pure glass matrix even in very small amounts; Affect the protecting character of these glasses very powerfully. The adding of iron to lead niobium phosphate glasses is estimated to growth the chemical stability and to fall the decomposition rate in aqueous surroundings [1]. iron have heavy-duty behavior on different material goods of glasses. A bulky sum of exciting readings are presented on the surroundings of Fe ion in various inorganic composites vice versa., SiO<sub>2</sub>, BO<sub>3</sub><sup>-3</sup>, P glasses [2-11] and also tellurite glass system [12,13]. The ions are exists altered filled with holes states with altered coordination in glass conditions, for examples as Fe<sup>+3</sup> transition ions polyhedron having four plane faces and polyhedron having eight plane faces and as Fe<sup>+2</sup> transition ion polyhedron having eight plane faces surroundings [14, 15]. The Fe<sup>+2</sup> and Fe<sup>+3</sup> transition ions are well known paramagnetic ions. Fe<sup>+2</sup> ion has a bulky magnetic anisotropy due to its strong spin-orbit interaction of the 3d orbital where as such anisotropy energy of Fe<sup>+3</sup> transition ions is small. The current investigation is at an understanding of the catalytic agent act of the iron ion on the representation of PbO-As<sub>2</sub>O<sub>3</sub> glass system by means of different analytical techniques.

1. F<sub>0</sub>: 40PbO-60As<sub>2</sub>O<sub>3</sub> ----- Pure Glass System
2. F<sub>1</sub>: 40PbO-60As<sub>2</sub>O<sub>3</sub>: 0.2 Fe<sub>2</sub>O<sub>3</sub> ----- Composite Glass System

3. F<sub>2</sub>: 40PbO-60As<sub>2</sub>O<sub>3</sub>: 0.4 Fe<sub>2</sub>O<sub>3</sub> ----- Composite Glass System
4. F<sub>3</sub>: 40PbO-60As<sub>2</sub>O<sub>3</sub>: 0.6 Fe<sub>2</sub>O<sub>3</sub> ----- Composite Glass System

## II. EXPERIMENTAL STUDIES

### 1.1 Glass Preparation

The studies of the PbO-As<sub>2</sub>O<sub>3</sub>-X Fe<sub>2</sub>O<sub>3</sub>, x values are taken from 0, 0.2, 0.4 and 0.6 mol%.

1. F<sub>0</sub>: 40PbO-60As<sub>2</sub>O<sub>3</sub> ----- Pure Glass System
2. F<sub>1</sub>: 40PbO-60As<sub>2</sub>O<sub>3</sub>: 0.2 Fe<sub>2</sub>O<sub>3</sub> ----- Composite Glass System
3. F<sub>2</sub>: 40PbO-60As<sub>2</sub>O<sub>3</sub>: 0.4 Fe<sub>2</sub>O<sub>3</sub> ----- Composite Glass System
4. F<sub>3</sub>: 40PbO-60As<sub>2</sub>O<sub>3</sub>: 0.6 Fe<sub>2</sub>O<sub>3</sub> ----- Composite Glass System

[16-18]. the materials used for the groundwork of the present glasses were analytical grade reagents pure glass of Lead Arsenate. The composites of requisite arrangements were carefully mixed in an agate mortar and heated in a platinum crucible. The heater used was a high temperature controlled heater (fig 1). The glasses were heated up to 550°C- 650°C for thirty minutes till a bubble free liquid was formed. The samples were next hardened at 300 °C in additional heater. The resulting soft was discharged on a rectangular brass mould held at room temperature. The sample ground and optically polished. The estimated final measurements of the glasses used for studying the physical assets are 1cm×1cm×0.2cm.

Revised Manuscript Received on July 05, 2019.

Y. Saritha Kumari, Malla Reddy Institute of Technology, Maisammaguda, Dhulapally, Secunderabad

B. Krishna Kumari, Malla Reddy Institute of Technology, Maisammaguda, Dhulapally, Secunderabad

Y. David Kumar, Malla Reddy Institute of Technology, Maisammaguda, Dhulapally, Secunderabad



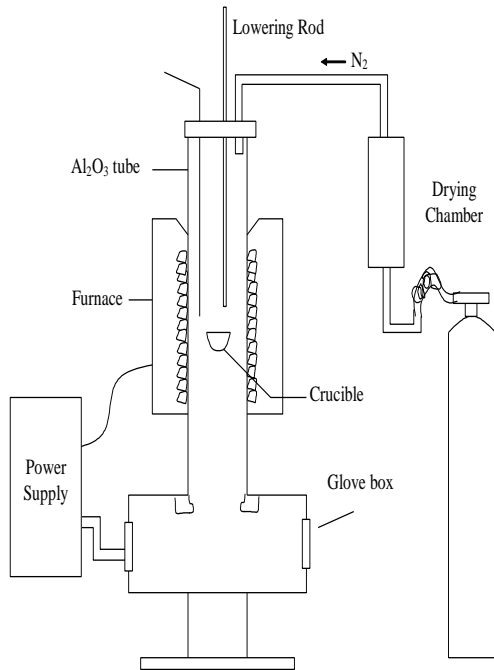

Fig – 1 Diagrammed of atmosphere-controlled furnace.

1.2 Crystallization Techniques

For crystallization the glass samples containing different collections of Fe<sub>2</sub>O<sub>3</sub> heat treated in an spontaneous regulatory heater at 400°C for four hours. After the heat treatment the models were extinguished in air to room temperature.

1.3 Physical Properties

The compactness of the crystallization glass is located resolute by the normal principle of Archimedes ‘the floating liquid. A straight evaluation balance for weighting. Majority glasses are adjourned on a very tinny copper strand was set in the involvement fluid bowl and weighed in the liquid and air. Using compactness and normal molecular weight other parameters such as Fe ion collection Ni, the polar on ranger<sub>p</sub>, etc., of the glasses are evaluated.

1.4 Optical Absorption bands

The absorption bands are lead and arsenate pure and glass ceramics be present verified using a Spectrometer wavelength is 250-1500 nanometers. The light rays entered the slitto light source (Ultra Violet ) is replicated by the glass M<sub>1</sub> and absorbed in to the single source. The D2 is used as a source from two hundred nm to source convertingλ and W<sub>1</sub>(VISIBLE) from source convertingλ1100nm, there are exchanged spontaneously according to the λ range. The position light source mechanically exact for supreme sensitivity and the source condenser mirror is positioned outside the source housing so as not to be exposed to heat rays and ozone. All the optical elements excluding the source are sealed from the external atmosphere by the window plate W so as to be dust free. The slit width of the monochromatic fixed at 2nm. The beam coming from the monochromatic is passed from side

to side the stray-light cut off F, reflected by glass M<sub>2</sub> and then split by the 1/2 glass M<sub>3</sub> into the sample and reference beams. Each beam passes through the respective cell to photo diode detector. [fig3]. In the electrical system of the spectrometer, the main control element is a microcomputer Control Processing Unit which controls the light source lighting, and switching filter converting λ scan, presentation, control panel & copier.

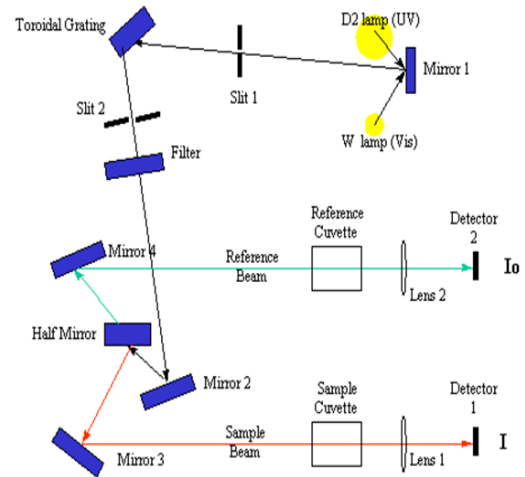

Fig – 2 optical system of the spectrophotometer

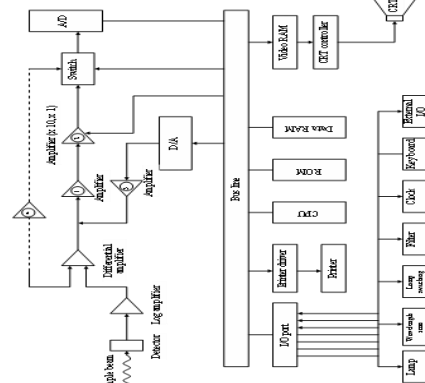

Fig. 2.3 electrical system of the spectrophotometer

III. RESULTS

1 Physical Properties

Study the standards of compactness d and deliberate  $\bar{M}$ , several parameters such as Ni and R<sub>i</sub> of the glass ceramics are estimated using the formulae [6].

Table -1 Pbo-As<sub>2</sub>O<sub>3</sub>- Fe<sub>2</sub>O<sub>3</sub> glasses physical parameters.

Sl.N o.	property	glass F <sub>0</sub>	glass F <sub>1</sub>	glass F <sub>2</sub>	glass F <sub>3</sub>
1	Compactness (g/cm <sup>3</sup> )	6.125 5	6.437 9	6.489 6	6.497
2	$\bar{M}$	208.9 8	208.8 6	208.7 3	208.6 0
3	N <sub>i</sub> (×10 <sup>21</sup> ions/c m <sup>3</sup> )	-	4.21	7.38	8.28
4	R <sub>i</sub> (A <sup>0</sup> )	-	5.821	4.393	3.911
5	polram radius R <sub>p</sub> (A <sup>0</sup> )	-	2.75	2.17	1.15



2 XRD Analysis

The XRD of the PbO-As<sub>2</sub>O<sub>3</sub> glasses (fig3.1) crystallized at 400 °C doped with different collections of nucleating proxyron ions designated that the composite samples involve PbFe<sub>4</sub> As<sub>5</sub>O<sub>11</sub>)<sub>2</sub>, Fe<sub>2</sub>PbAs<sub>2</sub>O<sub>6</sub> crystal points along with the PbO-As<sub>2</sub>O<sub>3</sub> crystal points. The glass ceramic exist the Fe<sup>3+</sup> and Fe<sup>2+</sup> states.

1.5 SEM&EDS

The SEM pictures some of the crystallized samples (fig3.2). scanning electron microscope pictures of the crystallized samples display well-known and unsystematically dispersed crystal ingrained in smooth matrix. The compound powder and paint of the samples in shown in(fig3.3). The Energy Dispersive Spectroscopy examination of the composite materials displays lead, Arsenat and Fe elements in various crystal-like phases. (Fig 3.4). X-Ray charts specify the practically equal arrangement of Fe ions in the entire composite materials



Fig – 3.2 SEM photographs of PbO-As<sub>2</sub>O<sub>3</sub>: Fe<sub>2</sub>O<sub>3</sub>

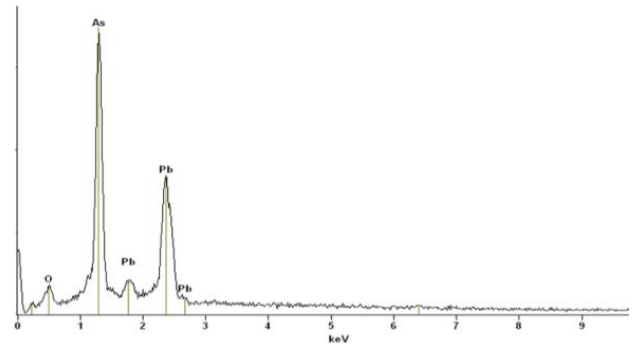

Fig.3.3 (a) EDS glass ceramic sample F<sub>0</sub>

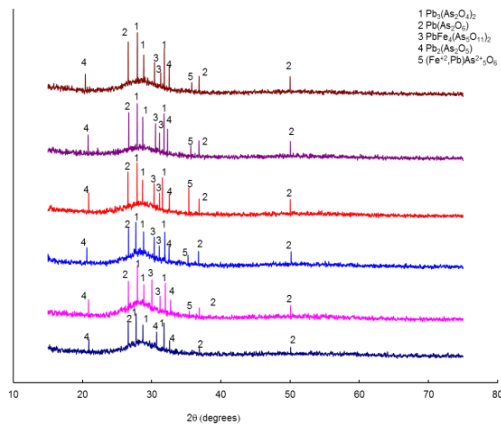

Fig. 3.1 XRD patterns of PbO-As<sub>2</sub>O<sub>3</sub>: Fe<sub>2</sub>O<sub>3</sub> Glasses

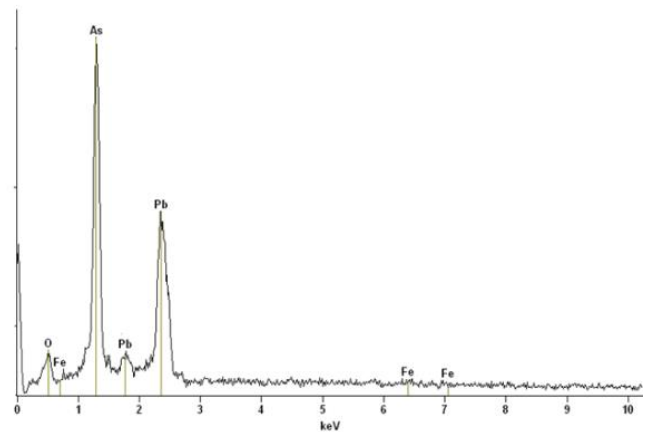

Fig.3.3 (b) EDS glass ceramic sample F<sub>2</sub>

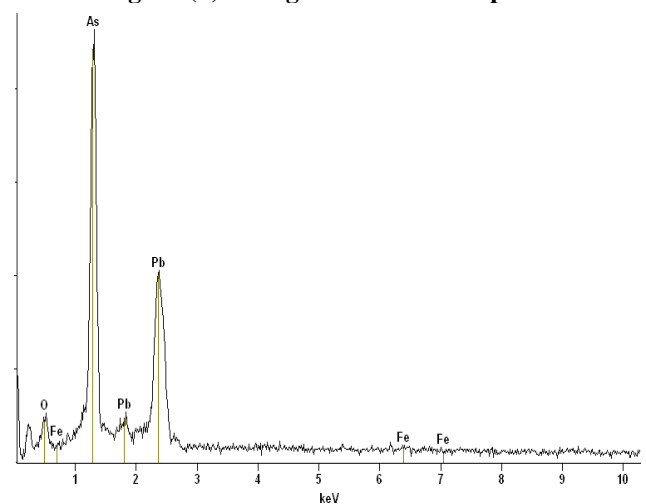
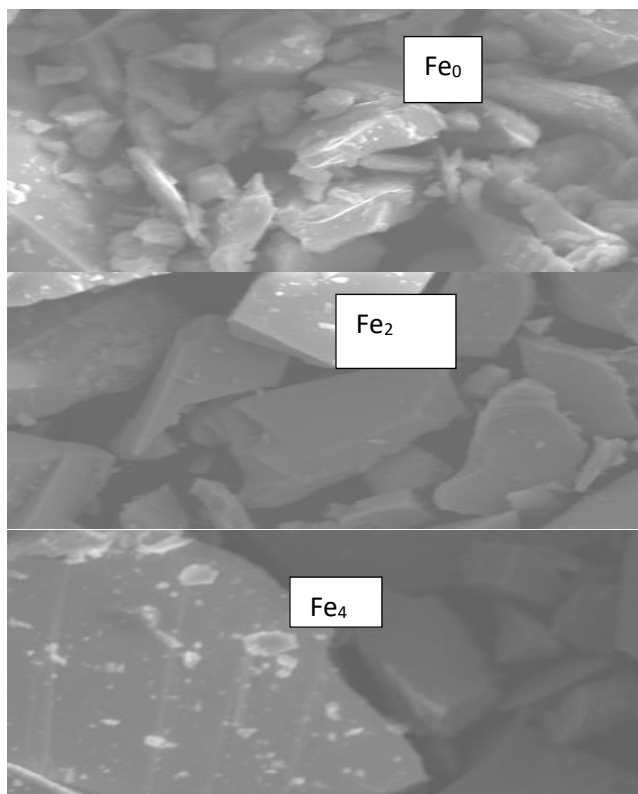

Fig.3.3 (c) EDS glass ceramic sample F<sub>4</sub>

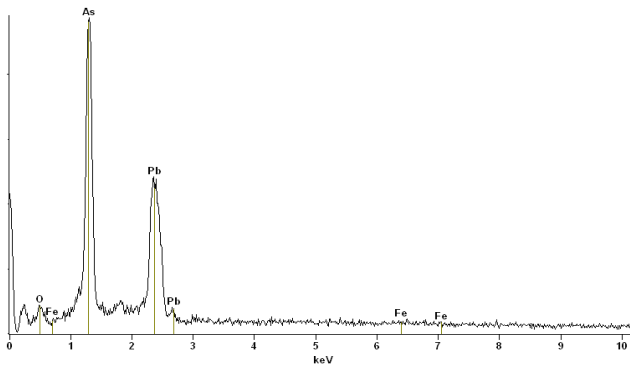

Fig.3.3 (d) EDS glass ceramic sample F5

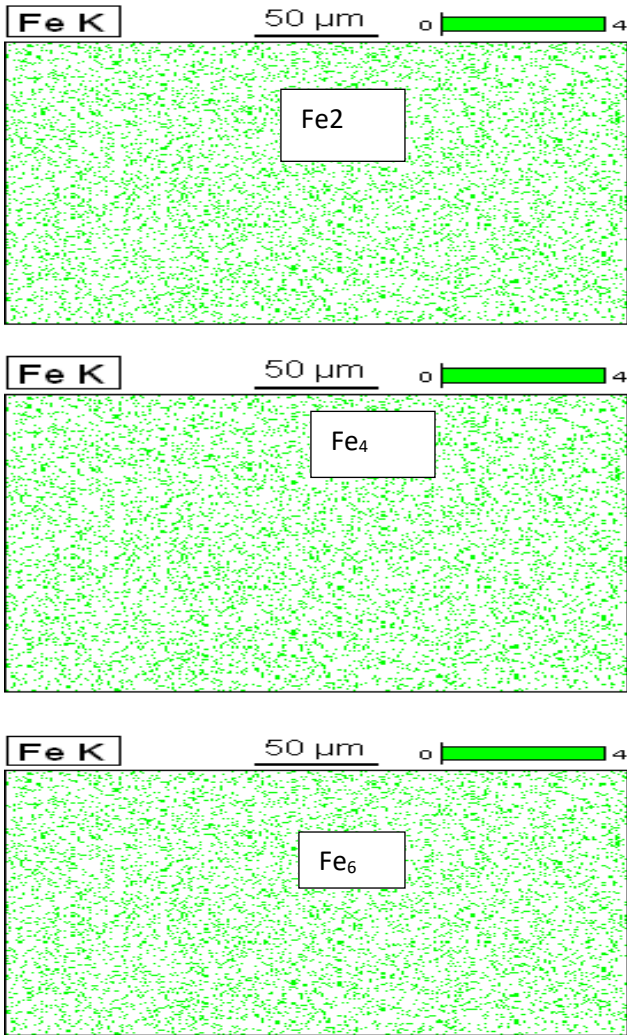

Fig. 3.4 PbO-As<sub>2</sub>O<sub>3</sub>:Fe<sub>2</sub>O<sub>3</sub>X-Ray mappings

3.4 Optical Absorption bands

The absorption peaks (fig 3.5) all the PbO-As<sub>2</sub>O<sub>3</sub>: Fe<sub>2</sub>O<sub>3</sub> glass ceramics verified at room temperature has displayed three absorption peaks at about 670, 560 nanometer; this peaks are recognized in line for to Fe<sup>3+</sup> transition ions. Moreover a peak at 900nm, recognized due to Fe<sup>2+</sup> [19] is also sited in the spectra. With growth in the doped Fe collection of up to 0.6 moll percentage the strength of peaks due to Fe<sup>2+</sup> transition is perceived to growth; when the attentiveness of Fe<sub>2</sub>O<sub>3</sub> is raised elsewhere 0.3 moll percentage a continuing reduction in the strength of

the peaks due to Fe<sup>2+</sup> transition could visibly be detected while that of band due to Fe<sup>3+</sup> transition is observed to increase.

Table-2 PbO-As<sub>2</sub>O<sub>3</sub> glass ceramics optical absorption peaks

Sl.No	Fe <sup>3+</sup> transitions (nm)		Fe <sup>2+</sup> transition (nm)
	<sup>6</sup> A <sub>1</sub> (t <sup>3</sup> <sub>2g</sub> e <sup>2</sup> <sub>g</sub> ) → a <sup>4</sup> T <sub>2</sub> (t <sup>4</sup> <sub>2g</sub> e <sub>g</sub> )	<sup>6</sup> A <sub>1</sub> (e <sup>2</sup> t <sup>3</sup> <sub>2</sub> ) → a <sup>4</sup> T <sub>1</sub> (e <sup>3</sup> t <sup>2</sup> <sub>2</sub> )	<sup>5</sup> T <sub>2g</sub> → <sup>5</sup> E <sub>g</sub>
1	560	670	900
2	560	670	900
3	560	670	900
4	560	670	900
5	560	670	900
6	560	670	900

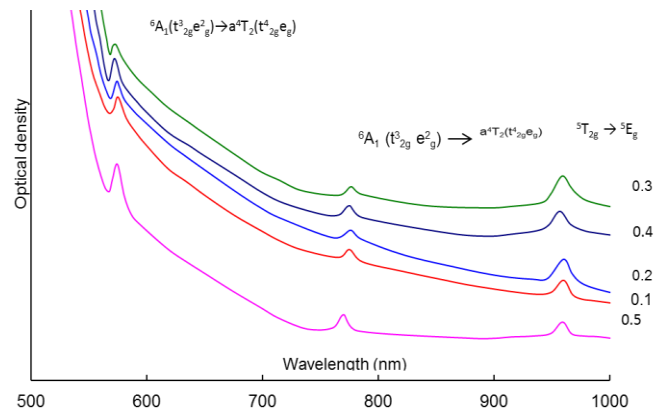

Fig.3.5 Optical absorption peaks of PbO-As<sub>2</sub>O<sub>3</sub>: Fe<sub>2</sub>O<sub>3</sub> glass ceramic samples.

IV. CONCLUSION

The main study of physical properties of crystallized (40-X) PbO-60As<sub>2</sub>O<sub>3</sub>: X Fe<sub>2</sub>O<sub>3</sub> glass are summarized below.

1. The developing of take shape Fe<sub>2</sub>O<sub>3</sub> causes a minor increase in the compactness of PbO-As<sub>2</sub>O<sub>3</sub>: X Fe<sub>2</sub>O<sub>3</sub> glasses; the suggestive of increasing structural compression of the material.
2. The XRD of the crystallized lead arsenate pure glasses doped with different collections of nucleating proxyiron ions designated that the composite samples involve PbFe<sub>4</sub> (As<sub>5</sub>O<sub>11</sub>)<sub>2</sub>, Fe<sub>2</sub>PbAs<sub>2</sub>O<sub>6</sub> crystal points along with the PbO-As<sub>2</sub>O<sub>3</sub> crystal points. The glass ceramics exist the Fe<sup>3+</sup> and Fe<sup>2+</sup> states.
3. The SEM pictures the crystallized samples PbO-As<sub>2</sub>O<sub>3</sub>: Fe<sub>2</sub>O<sub>3</sub> glasses display well known and unsystematically dispersed crystals ingrained in smooth matrix.
4. Energy Dispersive Spectroscopy examination of the pure & composite materials displays lead, Arsenat and Fe elements in different crystalline phases. X-Ray maps indicate therealistically equal arrangement of Fe ions in the entire composite materials.
5. The optical absorption peaks of all the PbO-As<sub>2</sub>O<sub>3</sub>: Fe<sub>2</sub>O<sub>3</sub> glass composites verified at



room temperature has displayed three absorption peaks at about 670, 560 nanometers; the peaks are recognized due to  $Fe^{3+}$  ions. Moreover a peak 900nm, recognized due to  $Fe^{2+}$  ions is also sited in the peaks. With growth in the doped Fe collection of up to 0.6 mol% the strength of peaks due to  $Fe^{2+}$  transition are perceived to growth; when the collection of  $Fe_2O_3$  is higher elsewhere 0.3 mol percentage a continuing reduction in the strength of the peaks due to reason the  $Fe^{2+}$  transition could obviously be perceived while that of band due to  $Fe^{3+}$  transition is observed to growth.

## REFERENCES

1. L.A. Boatner B.C. Sales, *Science* 226 (1986) 45.
2. K. W. Hansen, *J. Electrochem. Soc.* 112, (1965) 10; 113 (1996) 9
3. I. Ardelean, *Solid State Commun.* 27 (1978) 697; *Mod. Phys. Lett.* 3(1999) 801;
4. *Mod. Phys. Lett* 16 (2002) 485.
5. T. Hirayama Qui Hong-Hua, H. Sakata, *J. Ceram. Soc. Japan*, 3(1995) 32.
6. N.B. Chaurse, S. Gohkale, S.K. Kulkarni, *J. Phys. Chem. Solids* 60 (1999) 1705.
7. P. Giri Prakash, A. Murali and J.L. Rao, *Phys. Chem. Glasses* 43(2002) 102.
8. K. Nageswara Rao, N. Veeraiyah, *Indian J. Phys.* 74 (2000) 37;
9. G. Srinivasarao, N. Veeraiyah, *J. Phys. Chem. Solids* 63(2002) 705.
10. B.O. Mysen, *J. Non-Cryst. Solids* 95&96 (1987) 247.
11. G. Calas, Patian, *J. Solid State Commun.* 48 (1983) 625.
12. R. Iordanova, Y. Dimitriev, S. Kassabov, D. Klissurski, *J. Non-Cryst. Solids* 231 (1998) 227.
13. M. El-Samanoudy, A.I. Sabry, E.E. Shaisha and A. Bhagat, *Phys. Chem. Glasses* 32 (1991) 115; *J. Mater. Sci.*, 30 (1995) 3919.
14. H.H. Qui, M. Kudo and H. Sakata, *Mater. Chem. Phys.* 51, 233 (1997).
15. S.M.D. Nery, W.M. Pontuschka, S. Isotani, C.G. Rouse, *Phys. Rev. B* 49 (1994) 3760.
16. B.O. Mysen, *J. Non-Cryst. Solids* 95&96 (1987) 247.
17. A. Paul. chemistry of glasses, Chapman & Hall, London (1982).
18. S.R. Elliot. physics of amorphous materials, (Longman, London (1990)).
19. J.F. Shackl Ford. Introduction to materials science for Engineers (Macmillan, New York, 1985).
20. F. Albert Cotton, G. Wilkinson, Advanced Inorganic Chemistry, (Wiley Eastern Ltd., New Delhi) 1976.

## AUTHORS PROFILE



**I am Saritha Kumari**, I completed my M.Phil, M.Sc from the Acharya Nagarjuna University at Guntur, present I am working in mallareddy institute of technology at Hyderabad. I completed my m.phil degree in the year of 2008 from acharya nagarjuna university, I have A grade, M.Sc degree in the year of 2004 from acharya nagarjuna university, I have 85% percentage, my M.Phil research area is material sciences, my supervisor is Nallurveeraiyahagaru he is recently retired professor in acharya nagarjuna university, I attended international and national conferences, international conferences are two, one national conference and also I have a three published international journals, one international journal one is IOSR, second one is QUEST international journal and third one is IJSEER international journals. I also interested research areas are nanotechnologies, composite materials and applications of batteries. My teaching experience is 12 years, 4 years in vikasp.g college, vissannapeta, andhara Pradesh, 5 years in St. Martin's engineering college Hyderabad, telangana, remaining years Malla reddy institute of technology, Hyderabad, telangana, till date. and my Ph.D research area is sodium ion batteries and its properties. and also planned published the book it is processing condition. And also recently attended the faculty development Programme June 17<sup>th</sup> to 22<sup>nd</sup> 2019.



**I am Krishna Kumari**, I completed my M.Sc from the Acharya Nagarjuna University at Guntur, present I am working in mallareddy institute of technology at Hyderabad. I completed my m.sc degree in the year of 2008 from acharya nagarjuna university, I have A grade, M.Sc degree in the year of 2004 from acharya nagarjuna university, I have 85% percentage, I attended international and national conferences, international conferences are two, one national conference and also I have a three published international journals, one international journal one is IOSR, second one is QUEST international journal and third one is IJSEER international journals. I also interested research areas are nanotechnologies, composite materials and applications of batteries. My teaching experience is 6 years, 1 year in Malla Reddy engineering college (MREC) Hyderabad, telangana, remaining years Malla reddy institute of technology, Hyderabad, telangana, till date. and Ph.D research area is sodium ion batteries and its properties. and also planned published the book it is processing condition. And also recently attended the faculty development Programme June 17<sup>th</sup> to 22<sup>nd</sup> 2019.



**I Am David Kumar**, I Completed My M.Sc In A Research Associated And An Assistant Professor In Chemistry, Department Of Humanities And Sciences In Malla Reddy Institute Of Technology (MRIT), Hyderabad. He Has Total 9 Years Teaching Experience In Various Repeated Engineering Colleges Under Jtuh. He Completed His M.Sc In Organic Chemistry In The Year 2010. With First Class Under The Andhara University. He Has Attended A 3 Days International Conference Which Has Held In August 2018 At Malla Reddy Engineering College (MREC). He Had Experience On HPLC. And also recently attended the faculty development Programme June 17<sup>th</sup> to 22<sup>nd</sup> 2019.