

Performance Analysis of Closed loop Control of Diesel generator power supply for Base Transceiver (BTS) Load

Mohd Khursheed, M. A Mallick, Atif Iqbal

Abstract: This paper describes closed loop control of Diesel Generator (DG) supplying power to a Base Transceiver (BTS) load of a telecommunication tower, which is DC in nature. Detail modeling of Diesel Generator set has been presented. The stability analysis of governor and excitation system has been carried out in frequency domain. When DG source is connected to the BTS load bus through bridge rectifier, the output waveform distorted due to high odd harmonics content. To solve this problem a unity power factor rectifier has been designed. For the control operation of this UPFC rectifier, double loop mode control method has been used and results are presented. The complete system has been simulated in MATLAB-SIMULINK environment.

Keywords: BTS load, control, Diesels Generator, Excite, UPFC

I. INTRODUCTION

Diesel generator comprises of a diesel engine and a synchronous generator. The parts of diesel generator consist of speed governor, a diesel engine, an excitation system and a synchronous generator [9]. Diesel engine runs the synchronous generator while the speed control is obtained by governor mechanism. The diesel generator has two major components a speed regulator and an actuator. Diesel generators are ordinarily utilized in those zone where grid supply is either impossible or not accessible, for example, remote areas, rural region etc [8]. However, power generation from diesel generator is always avoidable due to its harmful effect on the environment and its high cost. Because of couple of characteristic favourable conditions of diesel generator mansion below, it is still in utilized as a backup power supply source in a microgrid [2].

- a) Full load operating condition can be attained rapidly,
- b) Time taken for starting and gaining full speed is lesser.
- c) Ability to maintain stability under varying load condition.
- d) Lesser space required for installation.

A. Components of Diesel Generator

A diesel generator consists of a speed governor, a diesel engine, an excitation system and a synchronous generator. The main components of the governor system are speed regulator and an actuator respectively as shown in Fig.1 (a). The variation in a.c. frequency of output voltage of generator is obtained by regulating the engine speed [13], [10]. The excitation system gives the current required to the field winding of a synchronous generator to generate the rated voltage at output terminals. The output voltage of diesel generator is controlled by controlling the excitation voltage applied to the field winding as shown in Fig. 1(b). Output voltage of synchronous generator depends on value of excitation voltage which is controlled by automatic voltage regulator (AVR). The diesel generators in this theses work is modeled as synchronous generators with excitation systems whose shaft is connected with the turbine of diesel engine. The turbine is provided with governor for controlling the speed of turbine.

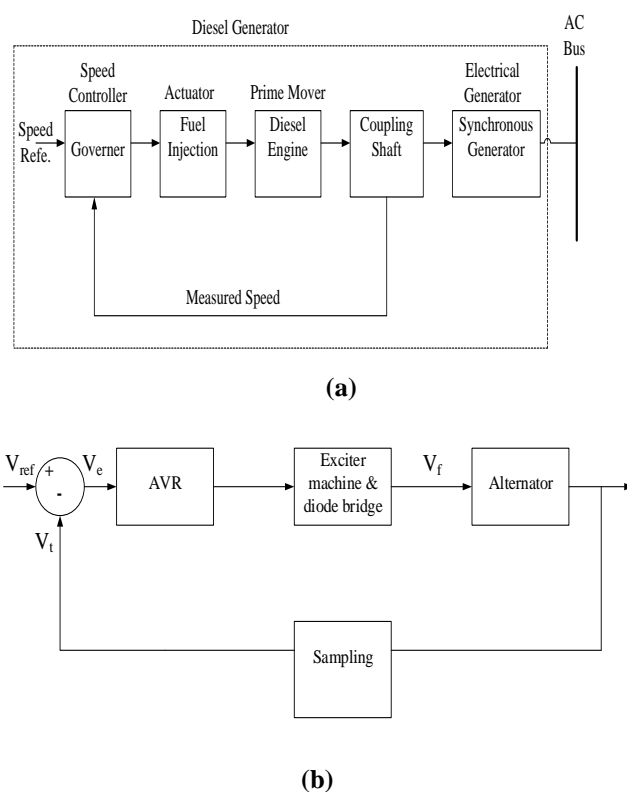

Fig. 1 Control scheme of diesel generator (a) Governor control scheme (b) Excitation Control scheme

Revised Manuscript Received on July 05, 2019.

Mohd. Khursheed Siddiqui, Associate Prof. in Electrical Engg. Dept in Integral University, Lucknow, India.

M.A. Mallick, Department of Electrical Engineering, Integral University, Lucknow, India.

A. Iqbal, Department of Electrical Engineering, Qatar University, Doha,



B. Diesel Engine

The engine was developed by German inventor Rudolf Diesel in 1893. A diesel engine is an internal combustion (IC) engine which converts the chemical energy of fuel into the mechanical energy [1], [6]. In an IC engines fuel consumes with packed air inside the ignition chamber and the result of the burning produces mechanical power.

C. Working of Diesel Engine

High temperature is created inside the combustion chamber of diesel engine by entering the air through the input filter at high pressure. Because of the heat of compressed air, as the small fuel droplets are sprayed on the compressed air, it start burn The heat of the compressed air vaporizes the fuel molecules from the surface of the droplets. There is a delay in the fuel burning because of vaporization process. Amid ignition procedure of fuel in the combustion chamber, an exceptionally high pressure is developed over the cylinder. Because of quick extension offered by combustion gas a pressure is created in the chamber, the pressure over the cylinder goes beyond limit and cylinder is driven outward because of this sudden pressure. Because of this outward movement of piston the developed power is transferred to the crank shaft. Because of high compression ratio, the diesel engine works at maximum thermal efficiency concerning normal external or internal burning energy systems.

D. Operation of Governor

The constant speed of the diesel generator is maintained by using diesel engine governor. In diesel engine, the speed regulation is obtained by managing the air/fuel ratio which is injected into the combustion chamber[12], [7]. The servomotor is used to control the opening of valve in order to maintain air/fuel ratio. The servomotor uses PID controller.

II. MATHEMATICAL MODELING OF DIESEL ENGINE

The diesel engine comprises of IC engine and governor. The operation of IC engine has been already discussed in section 1.2 The governor has two parts mainly, speed controller and actuator [14], [7]. The governor holds on the steady speed all through the working of diesel engine. An PID controller is used as a speed controller [11].

The controller and the actuator transfer functions could be given by Eq. (1) and Eq. (2) separately.

$$H_r = \frac{K_r(1+T_3s)}{(1+T_1+T_1T_2s^2)} \tag{1}$$

$$H_a = \frac{1+T_4s}{(1+T_5s)+(1+T_6s)} \tag{2}$$

Where,

K_r is the regulator gain,

T_1, T_2, T_3 are the regulator time constants

T_4, T_5, T_6 are the actuator time constants

The differential equations describing the diesel engine and speed regulation are shown by Equations [V. L Maleev, 1985]

$$\frac{dP_C}{dt} = -\frac{K_1}{\omega_{ref}} \Delta\omega \tag{3}$$

$$\frac{dm_B}{dt} = \frac{1}{\tau_2} \left(K_2 - \frac{K_2}{\omega_{ref}R} \Delta\omega m_B \right) \tag{4}$$

P_C is the compression ratio, m_B is the diesel engine fuel consumption rate (kg/sec),

K_1 is the governor summing loop amplification factor

R is the diesel engine permanent speed droop

ω_{ref} is the reference speed of engine in rad/sec

The engine is represented by a gain K_2 and a dead time τ_2

The dead time can be expressed as

$$\tau_2 = \frac{60S_t}{2N_n} + \frac{60}{4N} \tag{5}$$

Where

$S_t = 4$ for four stroke engine, N is the speed in rpm, and n is the number of cylinders.

The mechanical power (P_m) output produced as a result of combustion is

$$P_m = C_1 m \beta \eta \tag{6}$$

Where,

C_1 is proportionality constant and η is the efficiency.

Fig. 2 and Fig. 3 shows the complete block diagram and MATLAB / Simulink model of a diesel engine respectively. The speed controller is used for minimizing the error between actual and reference speed. The output signal of controller i.e. the position signal is fed as input to the actuator. The actuator adjusts the fuel injection to maintain the speed at constant value.

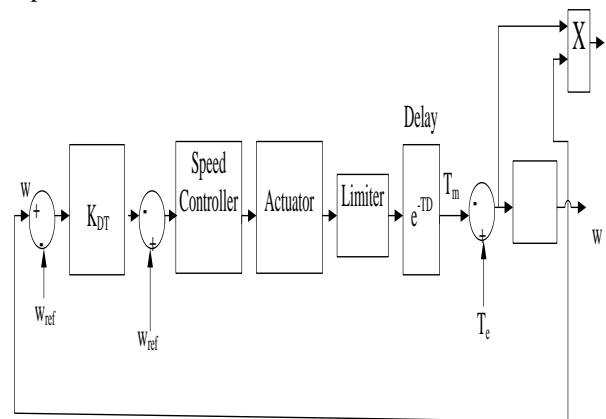

Fig 2 Block Diagram of Diesel Engine and Governor Model



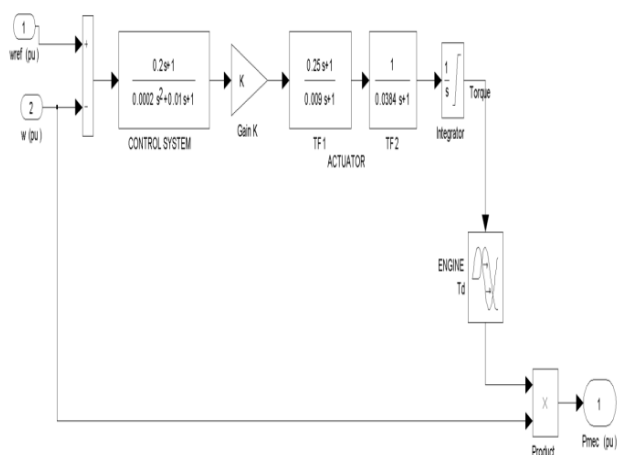

Fig 3 MATLAB/Simulink Model of diesel engine and governor model

III. EXCITATION SYSTEM (AVR)

While modeling of excitation system of synchronous generator, should take into account the actual excitation equipment performance for large, severe disturbances as well as for small perturbations in order to achieve accurate results of simulation. The main function of excitation system is to control the field current of the synchronous generator. The terminal voltage could be control by controlling the current in the field winding. As the time constant of the field winding is high, so field forcing for fast control of the field is required. When the behavior of synchronous machines is to be accurately simulated in power system stability studies, it is essential that their excitation systems should be modeled properly. The model should take into account of all disturbances which affects the synchronous machine performance. Excitation system models suitable for diesel generator connected to hybrid a.c./d.c. microgrid has been presented in this thesis. The hybrid microgrid is also able to operate in islanded mode. In order to maintain a constant terminal voltage, an automatic voltage regulator has been used for adjusting the excitation current of field winding of the synchronous generator.

A. Types of Excitation Systems used for Synchronous Generator

Based on excitation power source, there are three types of excitation systems as mentioned below [13], [18]

DC Excitation System

In this sort of exciter an independently or self-energized dc generator connected to motor or associated with main generator rotor shaft has been utilized. The field winding of the separately excited dc generator has been energized with the help of a permanent magnet ac generator, the three-phase output of which is converted to dc using rectifiers. For e.g. IEEE type DC1A. This kind of excitation was generally utilized around 1960 however at the present time AC excitation or static exciter is being utilized. Presently for older generating stations having DC excitation, the voltage regulator has been replaced by electronic regulators [16].

AC Excitation Systems

In this excitation system the supply to the field of main generator is given with the help of AC generator whose armature is connected to the shaft of main generator, with its field stationary. A rotating rectifier is used for converting the AC output of the exciter to DC. The supply to the field of the AC exciter is given by a pilot permanent magnet AC generator. The output of this generator has been converted to DC using rectifier circuit. For e.g. IEEE type AC1A.

ST Excitation Systems

In this type of excitation system static rectifiers has been used for converting AC terminal voltage into DC value for providing DC supply for generator field through slip rings. For e.g. IEEE type ST1A.

B. Mathematical Modeling of Excitation System (Type ST1)

In this thesis work, type ST1A type of excitation has been used for synchronous generator of diesel generator. All components in these systems are static or stationary. Static rectifiers, controlled or uncontrolled, are used to supply the excitation current directly to the field of the main synchronous generator via slip rings as shown in Fig. 4. The supply of power to the rectifiers is from the main generator (or the station auxiliary bus) via a transformer in order to get appropriate voltage level.

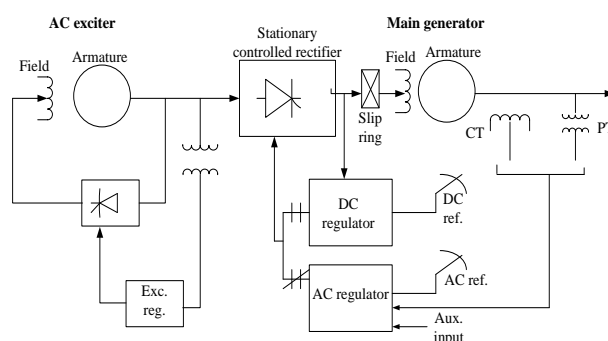

Fig. 4 Voltage source controlled static rectifier excitation system

The model of the Type ST1 voltage source controlled-rectifier exciter-based excitation system shown in Fig. 3.4. The excitation voltage is given using a transformer from the generator terminals and is coordinated by a controlled rectifier. The maximum voltage accessible from this type of systems is direct depends on the generator terminal voltage. In this sort of structure, exciter time constants are nearly nothing and stability issue generally not found. Then again, it might be required to decrease the transient gain of this type of exciter to improve damping. The model appeared in fig.7 is suitable to explain the effect of change in transient gain by putting either it in the forward path by means of time constants T_B and T_C (in this case the value of K_F is normally taken as zero), or by putting in feedback path with proper value of K_F and T_F as per requirement. [17], K_A and T_A represents the Voltage regulator gain and exciter time constants respectively. Though, the field voltage limits can be represent as a linear function of terminal voltage (except when the exciter is supplied from an auxiliary bus which is in turn not supplied from the generator terminals) and field current of generator respectively. it is possible



because of first quadrant operation of the bridge rectifier. For most transformer fed systems, K_C is quite small, permitting the term to be neglected for many studies.

C. Synchronous Machine Model

Only simulink model has been presented in this paper. which takes into account all relevant dynamic phenomena occurring in the machine [19] The detailed synchronous generator mathematical model has been explain in [3]. [4], [5]

IV. SIMULINK MODEL & SIMULATION RESULTS

A. Ratings of Diesel Generator connected

Parameters of diesel generator of power rating 10kVA, p.f 0.8 (lag), Voltage 400 V.

Table 1 Datasheet of Diesel Generator

DG Set Data Sheet	
Kva	10
Power Rating(kW)	8
Current (A)	14.49 A
Frequency (Hz) and Speed (rpm)	50/1500

Table 2 Parameters of Three Phase Synchronous Generator

S. No.	Parameters	Symbol	Values
1.	d-axis synchronous reactance	X_d	3.23 pu
2.	d-axis transient reactance	X_d'	0.21 pu
3.	d-axis sub-transient reactance	X_d''	0.15 pu
4.	q-axis synchronous reactance	X_q	2.79 pu
5.	q-axis sub-transient reactance	X_q''	0.37 pu
6.	Leakage reactance	X_l	0.09 pu
7.	d-axis transient O.C.time const.	T_{do}'	1.7 s
8.	d-axis sub-transient open circuit time constant	T_{do}''	0.008 s
9.	q-axis sub-transient O. C. time constant	T_{qo}''	0.004 s
10.	Arm. resistanc	R_s	0.017 pu

Table 3 Parameters of Governor of Diesel Generator

Parameters of Governor			
S. No.	Parameters	Symbol	Values
1.	Governor gain constant	K_r	40
2.	Electric Control Box time constant	T_{r1}	0.01 s
3.	Electric Control Box time constant	T_{r2}	0.02 s
4.	Electric Control Box time constant	T_{r3}	0.02 s
5.	Actuator time constant	T_{a1}	0.15 s
6.	Actuator time constant	T_{a2}	0.009 s
7.	Actuator time constant	T_{a3}	0.0384 s
8.	Inertia constant	H	1 s
9.	load damping coefficient	D	0.1
10.	Delay time	T_d	0.03 s

Table 4 Parameters of Exciter of Diesel

Parameters of Excitor			
S.No.	Parameters	Symbol	Values
1.	Regulator gain	K_A	300
2.	Regulator time constant	T_A	1 ms
3.	Compensator time constant	T_B	0 ms
	Compensator time constant	T_c	0 ms
3.	Exciter time constant	T_E	0.0 ms
4.	Regulator stabilizing circuit gain	K_F	0.001
5.	Regulator stabilizing circuit time constant	T_F	100 ms
6.	Exciter self-excitation at full load field voltage	K_E	100



B. Governor Model Taken into Consideration

In this governor model, the droop gain K_{DT} is obtained after comparing the actual speed signal with that of the reference signal with the help of frequency droop. The reference value of the fuel input has been adjusted by the output of the frequency droop. The modeling of speed governor system and that of actuator has been described [14] with the help of second-order transfer functions. The important parameter of a diesel engine is its delay time T_D which makes a delay in performance. The bode approximation for delay block is given by the eq. (7)

$$e^{-sT_d} = \frac{10 - 5sT_d + T_d^2 s^2}{10 + 5sT_d + T_d^2 s^2} \tag{7}$$

The transfer function of speed regulator and the actuator are given by,

$$G_{rg}(s) = \frac{K_r(1 + sT_{r3})}{(1 + sT_{r1} + s^2T_{r1}T_{r2})} \tag{8}$$

$$G_{ag}(s) = \frac{K_r(1 + sT_{a1})}{s(1 + sT_{a2})(1 + sT_{a3})} \tag{9}$$

Where, K_r is the regulator gain, T_{r1} , T_{r2} and T_{r3} are the regulator time constants, T_{a1} , T_{a2} and T_{a3} are the actuator time constants. The complete diesel engine and speed regulator block diagram is shown in Fig.3.5 using the above dynamical relations for actuator and regulator. The Fig.6 shows the bode plot of closed loop transfer function, $\frac{\omega(s)}{\omega_{ref}(s)}$ of speed controller used in governor of diesel generator shown in Fig.5. The parameters of speed governor are given in table 3. The bandwidth of speed controllers is observed to be 11 Hz.

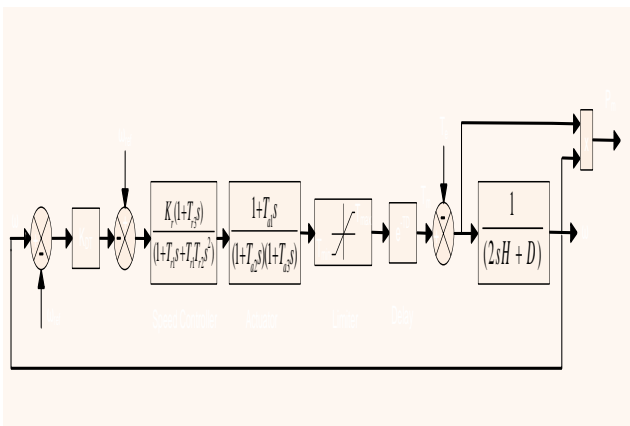

Fig. 5 Control scheme of Governor used in diesel generator

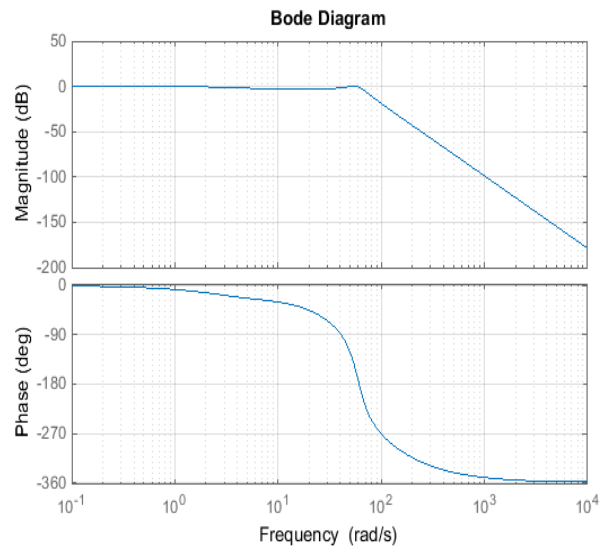

Fig.6 Bode plot closed loop transfer function $\frac{\omega(s)}{\omega_{ref}(s)}$ of Governor

C. Simulink Model of Exciter

In this thesis work, the Type ST1 Excitation scheme is used for diesel generator [9], [15]. The modeling of Type ST1 Excitation System is considered for designing the parameters of controllers and for stability study. The Fig.8 shows the bode plot of closed loop transfer function of $\frac{v_f(s)}{v_{ref}(s)}$ of ST1 excitation scheme used in exciter of diesel generator shown in Fig.7. The parameters of speed governor are given in table 4. The bandwidth of exciter is observed to be 64 Hz.

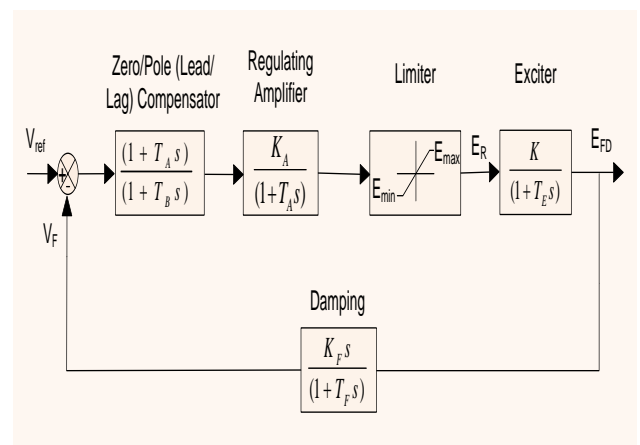

Fig.7 Control scheme of ST1 excitation system

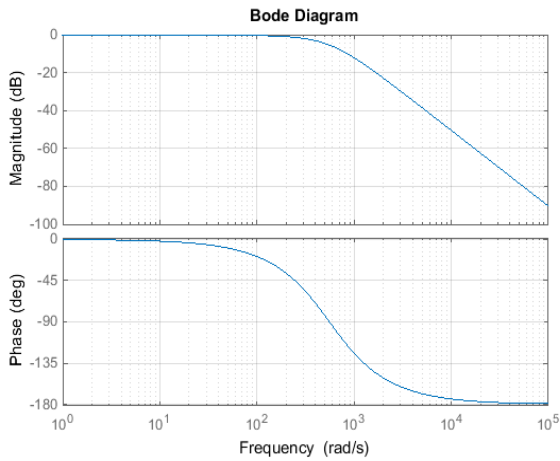

Fig.8 Bode plot of closed loop transfer function of STI type excitation scheme

Base Values: Base Voltage $V_b = 230 \text{ V}_{(rms)}$, Base Power $S_b = 10 \text{ KVA}$, Base Impedance $Z_b = 15.87 \text{ ohm}$

The Fig. 9 shows the complete Simulink model of the three phase diesel generator. The exciter provides sufficient excitation voltage to the field winding of the three phase synchronous generator so as to produce a output voltage of 230 V (rms) at rated load. The governor system adjusts the fuel input to the diesel generator so as to produce output voltage and current at a frequency of 50 Hz. Initially, a resistive load of 15.87 ohm is connected the output of three phase synchronous generator. At the time instant of $t = 10 \text{ s}$, diesel generator supplied power to a three phase R-L load. The value of $R = 12.7 \text{ ohm}$ and the value of $L = 30.3 \text{ mH}$. The waveforms of the turbine output power, exciter output voltage, actual exciter voltage and rotor speed are shown in Fig.10. The output voltage generated and current supplied by the diesel generator has been described in Fig.11. Fig.12 hows the Zoomed version of Output terminal voltage and load current supplied by diesel generator to the load connected at its output terminals. Fig.13 shows the waveforms of the output active and reactive power supplied by diesel generator to the loads connected across its terminals.

Table 5 Parameters of Three Phase Transformer

Data Specification of Transformer	
kVA	10
Volts	230 V/21 V
Frequency	50 Hz
Phase	3
Ampere	15A/ 159A
Impedance	4.87%

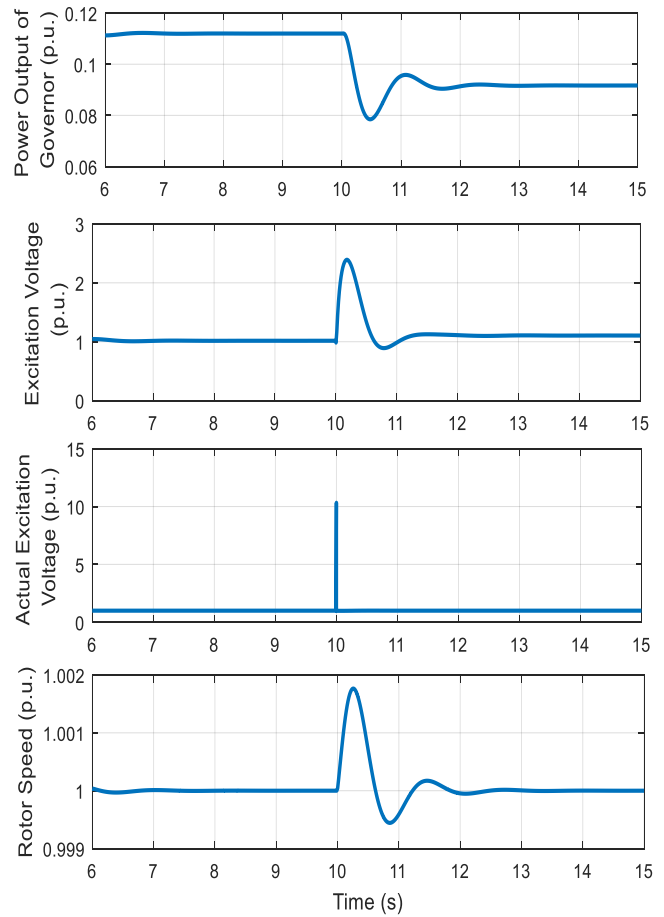

Fig. 10 Waveforms of the turbine output power, exciter output voltage, actual exciter voltage and rotor speed (p.u. values)

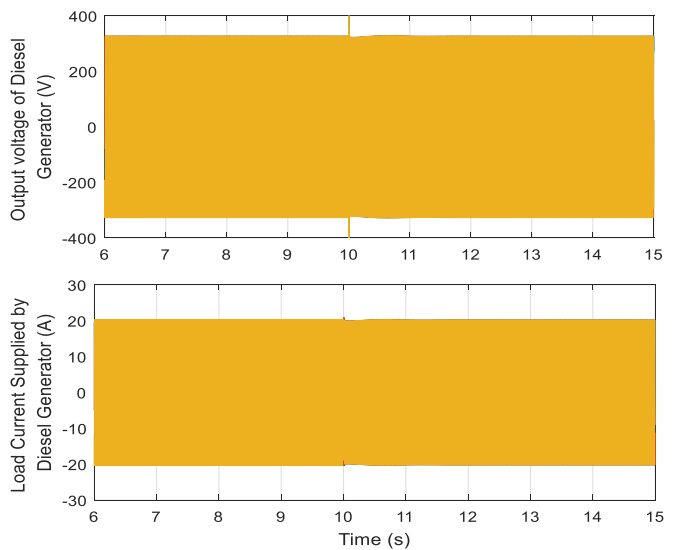

Fig. 11 Output terminal voltage and load current of diesel generator

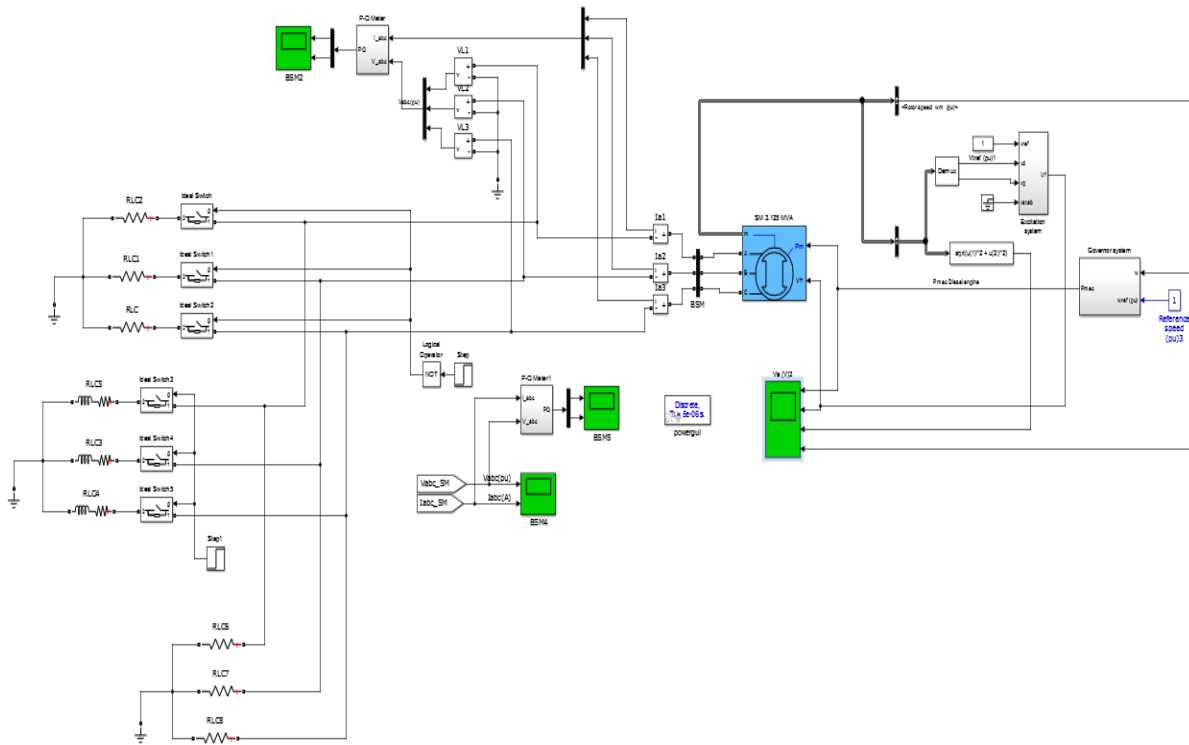

Fig 9 Complete Simulink Model of diesel generator

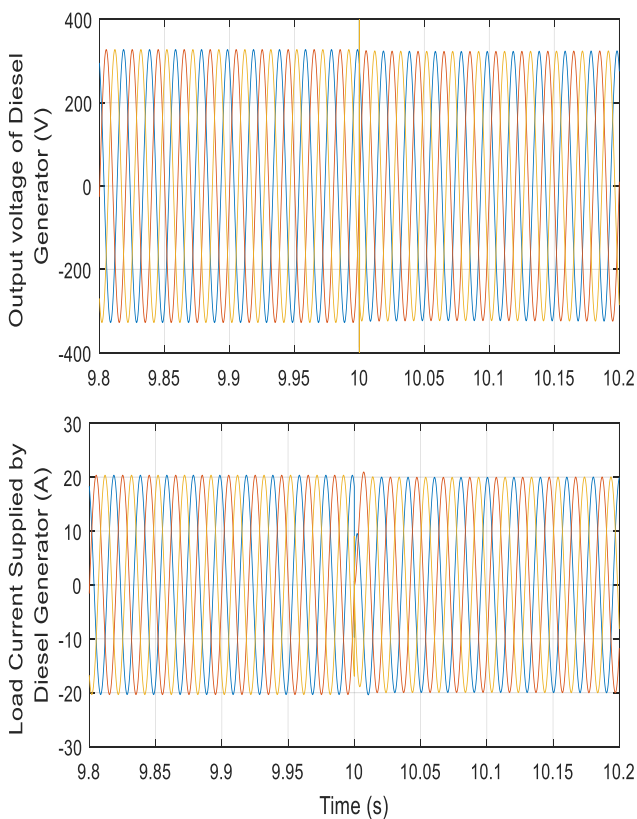

Fig. 12 Zoomed version of Output terminal voltage and load current of diesel generator

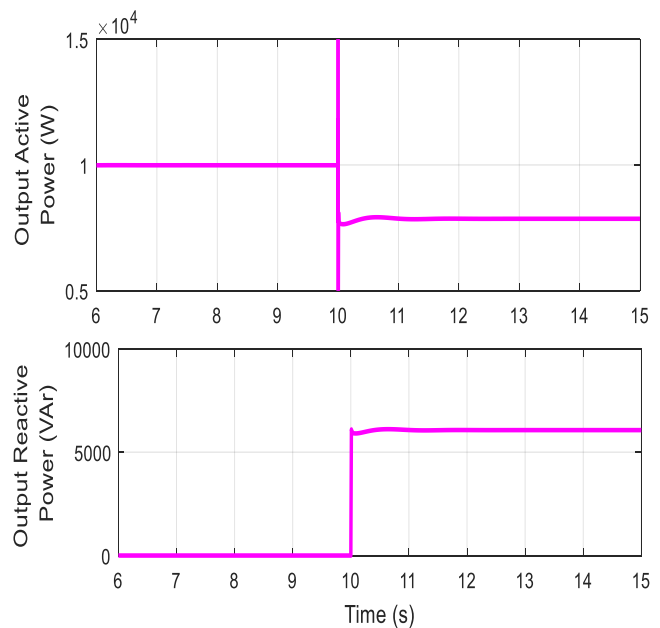

Fig. 13 Output active and reactive power supplied by the diesel generator

V. CONNECTION OF DG SET TO BTS LOAD

The output of synchronous generator is three phase a.c voltage which is alternating in nature. It cannot be directly connected to the BTS load input terminals. For this purpose, a three phase diode bridge rectifier is used to convert the ac output of diesel generator to the dc. However the operating voltage of the BTS load is 48 V (dc) and the put of diesel generator is 230 V (rms). Therefore a three phase step down transformer is connected between the diesel generator and the three phase rectifier.



Performance Analysis of Closed loop Control of Diesel generator power supply for Base Transceiver (BTS) Load

A. Selection of Three Phase Transformer

Output voltage of three phase diode bridge rectifier

$$V_{ro} = \frac{3\sqrt{3}}{\pi} V_{m2} = 48V$$

Where, V_{m2} is the voltage at secondary winding of step down transformer. From above, the value of V_{m2} is evaluated as =21 V (rms)

The voltage at input of primary of step down transformer is = 230 V (rms).

The turns ratio of step down transformer is $= \frac{230}{21} = 10.95 \approx 11$. The table 5 shows the parameters of the three phase transformer selected for supplying of BTS load. All the above mentioned components are simulated in Simulink/Matlab and the performance analysis of the complete system has been carried out. The Fig. 14 shows the Simulink model of diesel generator along with step down transformer and three phase diode bridge rectifier connected to BTS load.

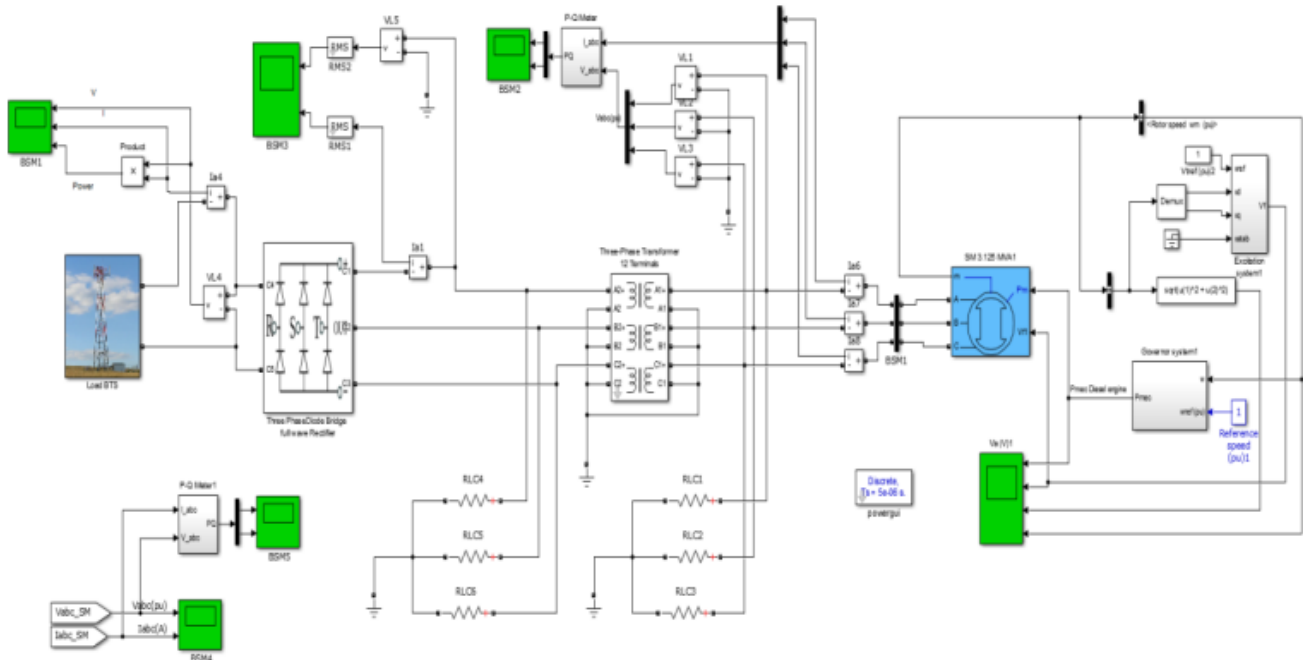

Fig 14 Simulink Model of diesel generator with step down transformer, three phase diode bridge rectifier and BTS load

The waveforms shown in Fig.15(a) described the three phase voltage output and the current supplied by the diesel generator to the BTS load. The three phase diode bridge rectifies is a nonlinear load and draws harmonic current from the synchronous generator as shown in Fig.15 (b) and distorts the current waveforms respectively. So, harmonic analysis is required for the current supplied by diesel generator to check whether harmonic contents are within the limit or not. In Fig.15 (b) the active and reactive power generated by the three phase synchronous generator are shown. Due to harmonics contents in currents, the ripple contents in active and reactive power waveforms are quiet high. The waveforms shown in Fig.15 (c) explain the variation of the output voltage, current and power supplied by three phase diode bridge rectifier. From these waveforms, it is clear that ripple contents in current and voltage waveforms are high which can be reduced using LC filter at output of three phase rectifier.

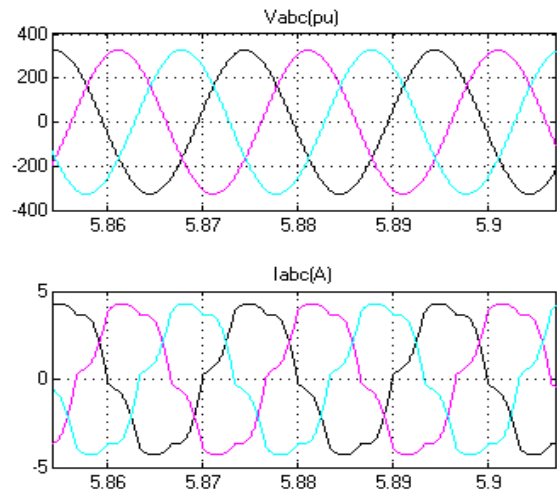

Fig 15 (a) Output voltage and current supplied by the diesel generator

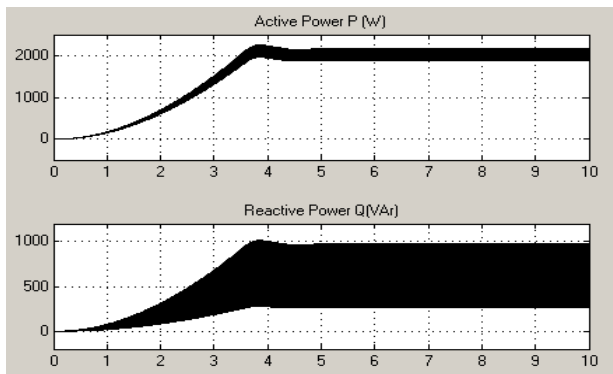

Fig. 15 (b) Output active and reactive power supplied by diesel generator

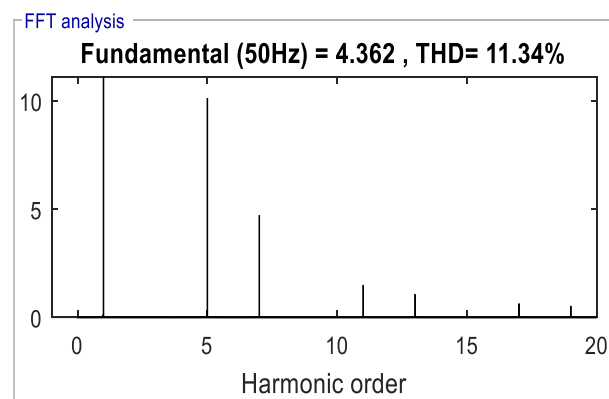

Fig. 3.15 (d) Harmonic spectrum of input current of three phase diode bridge rectifier

From the FFT analysis of the output current waveform as shown in Fig.15 (d), it has been observed that output of three phase rectifier contains more odd harmonic because of no half wave symmetry. The simulated result of the harmonics of current of three phase full bridge rectifier is shown in This type of converter contains odd harmonics as there has been no half wave symmetry. Such rectifiers additionally have dc component. It is obvious from the above discussion that these sorts of rectifiers produce harmonics component. In Electrical distribution system if such type of convertor has been used in large quantity for supplying load, harmonic injection would leads to power quality issue.. These harmonics over-burden the neutral conductors and transformers, producing more losses and decreased power factor.

VI. REMEDY

In order to solve above mentioned problem of three phase diode bridge rectifier, an active rectifier known as Three Phase Unity Power Factor Rectifier (UPFC) has been used [23]. In case of UPFC, the fundamental component of current and the supply voltage are in phase. Therefore, it draws no current harmonics from the supply [22], [24], [25].

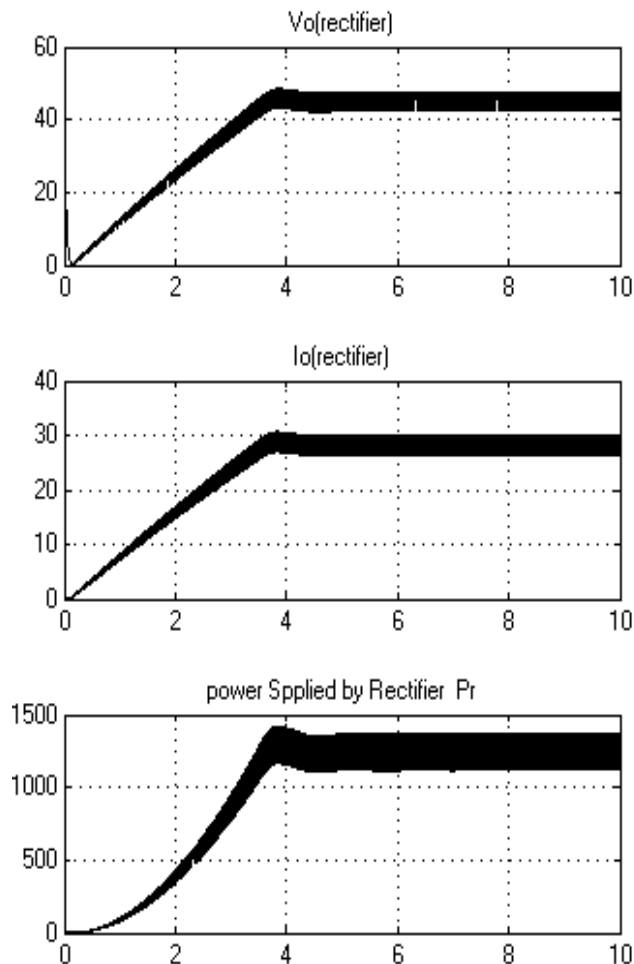

Fig. 15 (c) Output voltage, current and power of three phase diode bridge rectifier

A. Operation of UPFC

The control scheme of UPFC has been shown in Fig. 16. the closed loop structure of the UPFC comprises of a balanced three-phase source, a transmission line, filters and a PWM converter supplying power to the DC bus. The BTS load is connected to DC bus. Transmission line equivalent parameters have been represented as R_{eq} , L_{eq} , while that of filter parameters are given by C_{eq} , R_f filter of L_f , C_{dc} is a DC-link capacitor. The PWM converter comprise of six IGBTs as ideal switches. No loss and no system harmonics have been assumed. For maintaining constant link capacitor voltage (i.e, V_{dc}^*) and unity power factor at input AC side (I_q^* equal to zero), the PWM converter utilized vector controller technique First of all, voltage angle has been calculated by feeding the line voltage V_{abc} to the PLL (Phase Locked Loop). This angle signal has been utilized for abc to dq axis transformation of electrical quantity i.e. voltage, current. Afterward, the dq-axis values and the DC-link voltage value has been utilized for decoupled control. These controllers are specified as Current controller and DC-link voltage controller. Lastly, the reference voltages generate by the controller has been sent to the PWM block (Pulse Width Modulation) to make the switching sequence S_{abc} ($S = 1$ implies upper switch ON, lower turn OFF; $S=0$ implies

upper turn OFF, lower switch ON).

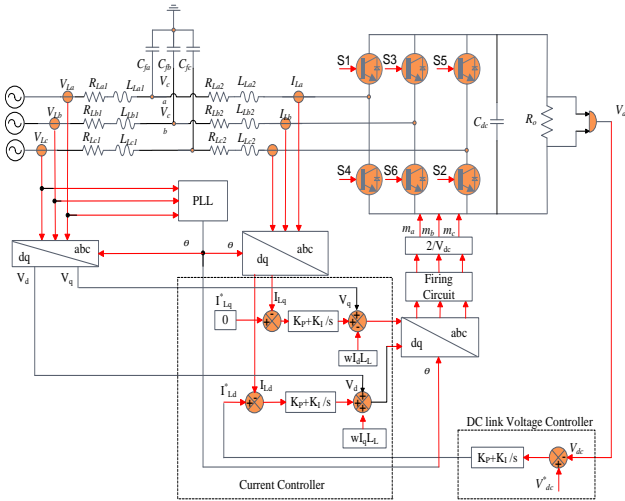

Fig. 16 Closed loop control scheme of UPFR

B. Control Scheme of UPFC

The broad control objectives of the grid-side converter are as follows [20], [21]

- The UPFC is designed so as to maintain the DC link voltage (V_{dc}) constant. So the responsibility of maintaining a constant V_{dc} lies with the controller associated with the UPFC. Hence maintaining the DC link voltage constant is the first objective of UPFC controller.
- For a fixed power rating, the peak of the grid current is minimum only when the operations a unity power factor. So, the second purpose of the UPFC controller is to maintain working of convertor at unity power factor.

To achieve these two control objectives a double loop control scheme has been used. These two loops are known as inner Current controller and the outer DC-link voltage controller. The voltage control forms the slow outer loop, while grid current (i_L) control constitutes the fast inner loop [26]. The control strategy structure has been shown in Fig.17. The chief advantage of using a two loop control scheme (as mentioned above) is that each variable see the other as constant. For example, the inner control loop is faster than the outer V_{dc} control loop that by the time V_{dc} starts to react to any change or disturbance i_g has already reached its steady state. Similarly from the perspective of i_g , the outer loop is slow that V_{dc} changes very slowly and it is as good as constant

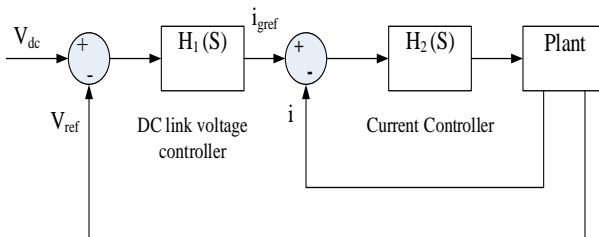

Figure 17 Two Loop Control Scheme Synchronous PI control

Using Clarke and Park transformations, the current measurements are transformed to DC quantities, then, a

simple PI controller give good convergence to reference values. PI controllers are inherently incapable of giving zero steady state control error for a dc reference. The integral action removes the error only if the reference value is constant in steady state.

Table 6 Parameters of UPFC

S.No.	Parameters	Symbol	Values
1.	Switching Frequency	f_s	5 kHz
2.	Diesel Generator Side Filter Inductance	L_1	1.5mH
3.	Diesel Generator Side Filter Capacitance	C_f	200 μ F
4.	Grid side Inductance	L_2	1mH
5.	Internal resistance of L_1	R_1	0.1 Ω
6.	Internal resistance of L_2	R_2	0.1 Ω
7.	Rated Power	P	10 KW
8.	Grid Voltage	V_{abc}	230V (peak)
9.	DC Link Capacitance	C_{dc}	5 mF
10.	PI controller of current control loop	K_p+K_i/s	1+100/s
11.	PI controller of dc link voltage controller	K_p+K_i/s	2.5+120/s
12.	Reference DC Voltage	V_{dc}	50 V

The Fig. 18 shows the closed loop control scheme of UPFR. The parameters of the UPFR are given in table 5. The waveforms shown in Fig. 19(a) gives the variation of output voltage and current supplied by three phase UPFR. From the waveforms, it is clear that current waveform is free from distortion. The Fig. 19(b) shows the voltage between the two legs of three-phase UPFC which are PWM in nature. Fig. 19(c) shows the waveforms of output active and reactive power generated by the diesel generator. the waveforms shown in Fig. 19(d) gives the output dc link voltage, current and power supplied by the UPFR to the BTS load. From these waveforms it is observed that the ripple contents in the waveforms of voltage, current and power are less as compared to the case of three diode bridge rectifier. Also the UPFR is generating the voltage and current required by the BTS load.



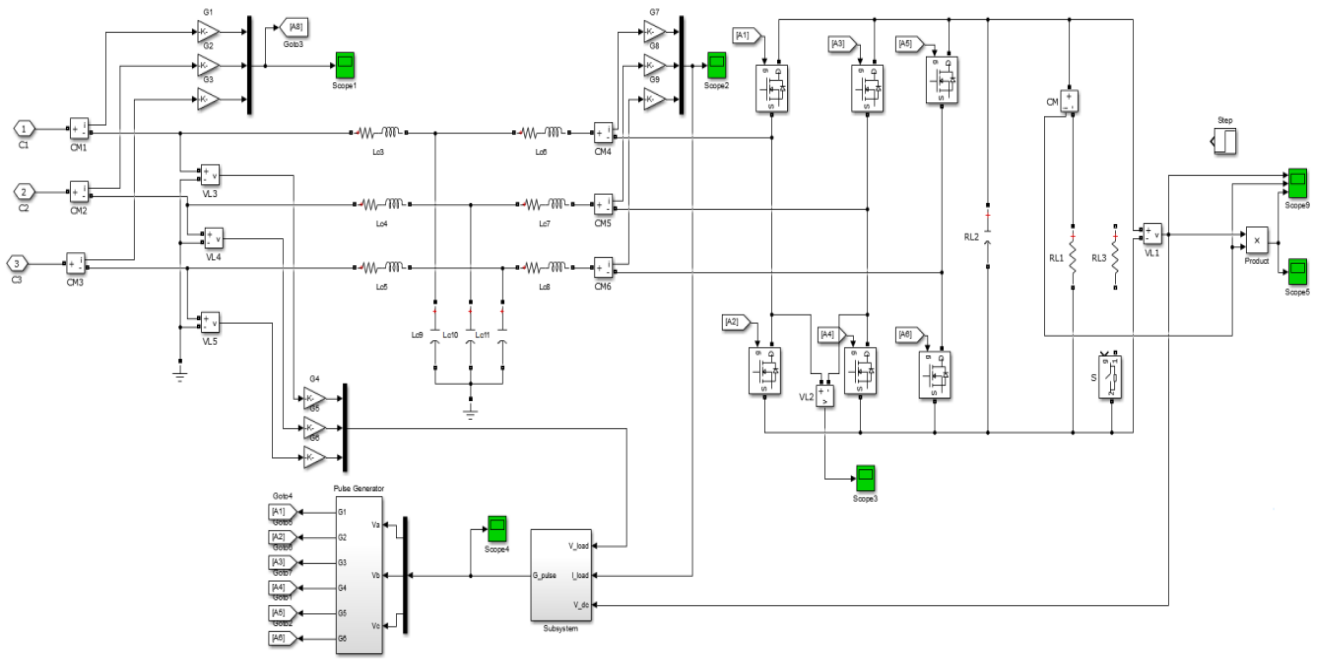

Fig. 18 Simulink model of closed loop control scheme of UPFR

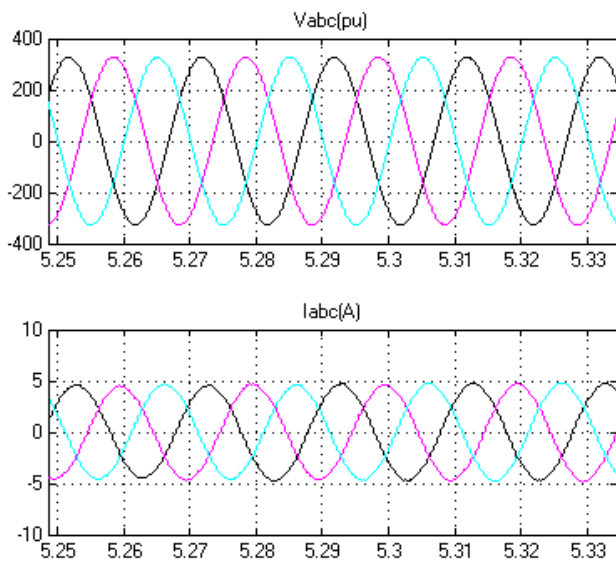

Fig. 19 (a) Output voltage and current supplied by diesel generator

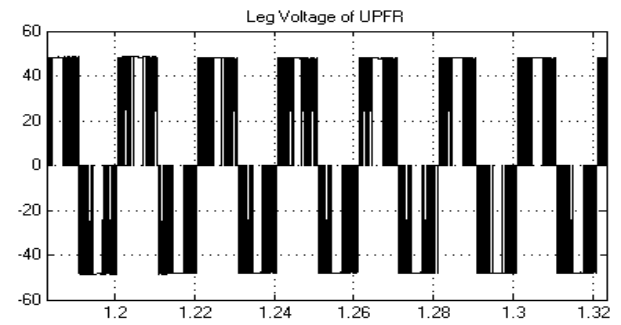

Fig. 19 (b) Output leg voltage of UPFR

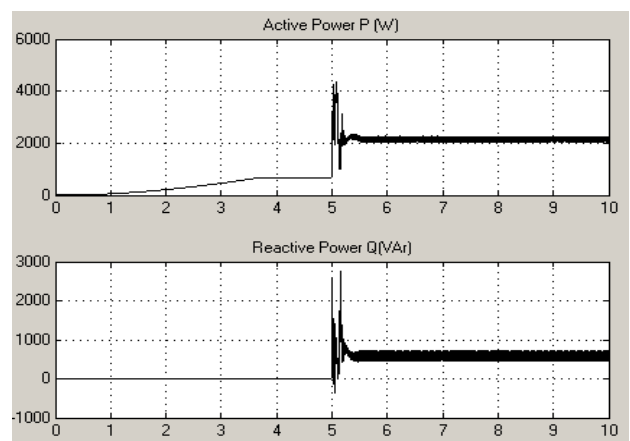

Fig.19 (c) Output active and reactive power of diesel generator

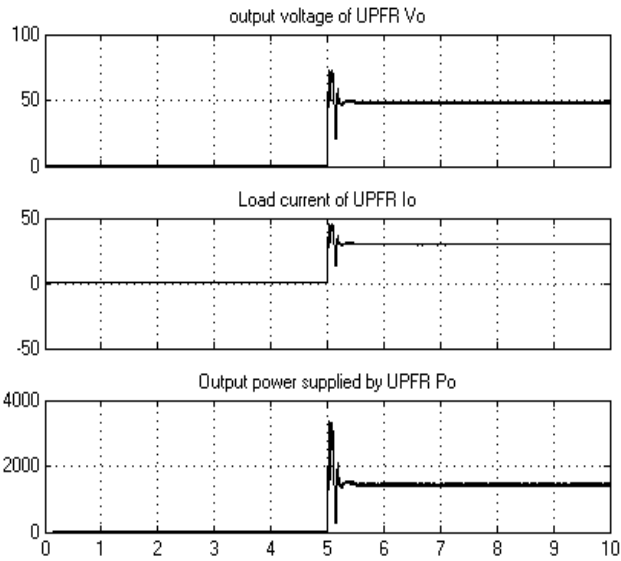

Fig. 19 (d) Output voltage, current and Power of UPFR

VII. CONCLUSION

This paper deals with the detail modeling of Diesel Generator set. Separate modeling of different component i.e. governor system, excitation system and synchronous generator is also discussed in detail. The stability analysis of governor and excitation system has been carried out in frequency domain. The frequency response of closed loop transfer function of the governor and excitation system has been examine with the help of bode plot. From the behaviour it is conclude that these systems are stable. It also conclude from the wave form of the voltage, current and power output, while using bridge rectifier to connect to the dc BTS load bus, that these wave form are distorted due to high odd harmonics content. To solve this problem a unity power factor rectifier has been designed. For the control operation of this UPFC rectifier, double loop mode controller has been used. Finally from the output voltage, current and power wave form of the UPFC it is observed that these wave have less distortion means have less harmonic content as compared to the 3 phase bridge rectifier. Thus the UPFC is the better option to connect the generator to BTS load as compared the bridge rectifier.

REFERENCES

- G. Konar, A.K. Singh, N. Chakraborty, "Modeling and Simulation of Stand Alone Micro Hydro – Diesel Hybrid Power Plant for Indian Hilly Region", IET, Chennai Fourth International Conference on Sustainable Energy and Intelligent Systems (SEISCON 2013) 12-14 Dec 2013
- T. Theubou, R. Wamkeue, I. Kamwa, "Dynamic Model of Diesel Generator Set for Hybrid Wind-Diesel Small Grids Applications", 25th IEEE Canadian Conference on Electrical and Computer Engineering (CCECE), 978-1-4673-1433-, 2012.
- Željko Špoljarić, Krešimir Miklošević, Vedrana Jankovic, "Synchronous Generator Modeling Using Matlab", Published, 2010
- Z. Spoljaric, K. Miklosevic and Z. Valter, "Analysis of Synchronous Motor Drive using SimPowerSystems", DAAAM International, Vienna, Austria, pp. 1133-1135, October 2009 [Proceedings of 20-th International DAAAM Symposium, Vienna, Austria], ISBN 978-3-901-509-70-4, ISSN 1726-9679.
- Attila Fodor, Attila Magyar, Katalin M. Hangos, "Dynamic Modeling and Analysis of a Synchronous Generator in a Nuclear Power Plan", International Conference on Applied Electronics, 2010
- S. Krishnamurthy, T. Jahns, and R. Lasseter, "The operation of diesel gensets in a certs microgrid," in Power and Energy Society General Meeting - Conversion and Delivery of Electrical Energy in the 21st Century, 2008 IEEE, July 2008, pp. 1–8.
- N. Al-Khayat, J. Al-Tayie and R. Seliga, "Stand alone adjustable speed power generating set", Proc. Intl conf. on harmonics and power quality, 2002, Vol. 2, pp- 639 – 643.
- G. S. Stavrakakis, G. N. Kariniotakis, "A Generals Imulation Algorithm for The Accurate Assessment of Isolated Diesel- Wind Turbines Systems Interaction - Part 1 : A general multi machine power system model", EEEI Transactions on Energy Conversion, Vol. 10, No. 3, September 1995
- K.E.Yeager,J.R.Willis,"Modelling of Emergency Diesel- Generators in an 800 MW Nuclear Power Plant," IEEETrans on Energy Conversion,Vol.8, No.3, September 1993.
- I.D.Hassan,R.Weronick,R.M.Bucci, "Evaluating The Transient Performance of Standby Diesel-Generator Units by Simulation,"IEEE Transaction on Energy Conversion, Vol.7, No.3, September 1992.
- S. Roy, O.P. Malik. G. S. Hope. "An adaptive control scheme for speed control of Diesel driven power plants". IEEE Trans. on Energy Conversion, vol. 6. no. 4. December 1991.
- D.C. Garvey, "A Digital Control Algorithm for Diesel Engine Governing", SAE Technical Paper Series , 850174, pp. 1-10, 1985.
- L.N. Hannett, F.P. de Mlello, G.H.Tylinski, W.H. Becker, "Validation of Nuclear Plant Auxiliary Power Supply by Test", IEEE Transactions on Power Apparatus and Systems, Vol. PAS-101, No. 9 September 1982.
- Le Luo, Lan Gao, Hehe Fu, "The Control and Modeling of Diesel Generator Set in Electric Propulsion Ship", I.J. Information Technology and Computer Science, 2011, 2, 31-37 Published Online March 2011 in MECS (<http://www.mecs-press.org/>)
- Saeed Mohajeryami, Zia Salami, Iman Naziri Moghaddam, "Study of Effectiveness of Under-excitation Limiter in Dynamic Modeling of Diesel Generators", Power and Energy Conference at Illinois (PECI), 978-1-4799-4881-9, April 2014, DOI: 10.1109/PECI.2014.6804572G
- odhwani and M.J. Basler, "A digital excitation control system for use on brushless excited synchronous generator" IEEE Transactions on Energy Conversion, Vol. 11, No. 3, September 1996, pp 616-620.
- Report, I.C., "Excitation System Models for Power System Stability Studies," Power Apparatus and Systems, IEEE Transactions on, vol.PAS-100, no.2, pp.494,509, Feb. 1981
- IEEE Committee Report, "Computer representation of excitation systems", Tram. on Power Apparatus and System, PAS - 87 (6). pp. 1460-1464, 1968.
- Jadric, "Modeling And Control of A Synchronous Generator With Electronic Load", Master of Science, Thesis, Virginia Polytechnic Institute and State University, Blacksburg, Virginia, January 1998.
- Ram iwas and B. Singh, "Solid State Control For Reactive Power Compensation and Power Quality Improvement of Wound Field Synchronous Generator Based Diesel Generator Sets", IET- Electric Power Applications, vol.9, no.6, pp.397-404, July. 2015.
- Ram Niwas, B. Singh, Sagar Goel and Chinmay Jain, "Unity Power Factor Operation and Neutral Current Compensation of Diesel Generator Set Feeding Three-phase Four-wire," IET- Generation, Transmission & Distribution, vol. 9, no. 13, pp. 1738 - 1746, Oct. 2015.
- Sewan Choi, "A Three-Phase Unity-Power-Factor Diode Rectifier With Active Input Current Shaping," IEEE Transactions on Industrial Electronics, vol. 52, no. 6, pp. 1711-1714 December 2005.
- Chandra, B. Singh, B. N. Singh and K. AI-Haddad, "An improved control algorithm of shunt active filter for voltage regulation, harmonic elimination, power-factor correction, and balancing of nonlinear loads," iEEE Trans. Power Elect., vol. 15, no. 3, pp. 495-507, May 2000.
- A.R. Prasad, P.D. Ziogas, S. Manias, "An active power factor correction technique for three-phase diode rectifiers", IEEE Trans. Power Electron., vol. 6, no. 1, pp. 83-92, 1991.
- W. Olive, "Digital Simulation of Synchronous Machine Transients", IEEE Trans. on

Power Apparatus and System. vol. PAS-87. no. 8. pp. 1669-1674, August 1968.

26. R. Ahmadi, D. Paschedag, and M. Ferdowsi, "Closed-loop input and output impedances of DC-DC switching converters operating in voltage and current mode control," in Proc. Industrial Electron. Conf., pp. 2311–2316, 2010.

AUTHORS PROFILE



MMohd. Khursheed received his B.E. and M.Tech in (Electrical Engg.) degree in 2006 & 2008 respectively from Aligarh Muslim University, Aligarh, India. He is presently working as Associate Prof. in Electrical Engg. Dept in Integral University, Lucknow, India. He is a life member of IEL. His area of interest is Renewable Energy System, Power Electronics, Electrical machine drives, Power System & Control. He has many publications in national and international journals and conferences.



M.A. Mallick received BSc.Engg. and M.Sc. Engg. degree from Aligarh Muslim University, Aligarh, India in 1994 and 1998, respectively. He received his PhD degree in the year 2011 from Integral University, Lucknow. He is working as Professor in the Department of Electrical Engineering, Integral University,

Lucknow, India. His research interests include renewable energy systems, power system modeling, instrumentation, electrical machines and drives. He is serving as Fellow of IE (India), Associate member of IETE (India). He has many publications in national and international journals and conferences. He also served as reviewer of reputed national and international journals.



Atif Iqbal (M'09–SM'11) received the B.Sc. and M.Sc. degrees in electrical engineering from the Aligarh Muslim University (AMU), Aligarh, India, and the Ph.D. degree from Liverpool John Moores University, Liverpool, U.K., in 1991, 1996, 2006, respectively. He has been a Lecturer with the Department of Electrical Engineering, AMU, since 1991, he has been worked an Associate Professor the

Department of Electrical Engineering since 2016, AMU. Currently he is working as an Associate Professor with the Department of Electrical Engineering, Qatar University, Doha, Qatar. His current research interests include modeling and simulation of power electronic converters and control of multiphase motor drives.

Dr. Iqbal was a recipient of the Maulana Tufail Ahmad Gold Medal for standing first at B.Sc. Engineering Exams at AMU in 1991. He was a recipient of the Best Research Papers Awards at the 2013 IEEE International Symposium on Information Theory and the 2013 IET International Conference on Sustainable Energy and Intelligent System.