

# Design & Development of Contactless Valve for Adhesive Fluid Flow

Pavankumar R. Sonawane, Dhirajsingh Bhagatsingh Bhakuni, Nilesh Rajitkumar Dubey, Harsh Deepak Joglekar, Aniket Bajarang Jawale

**Abstract:** Valves are the components in a fluid flow or pressure control system that regulates either the flow or the pressure of the fluid. Pinch valve is control and shutoff valve, used for slurry application where abrasive or corrosive, powders or granular substances are present. The Objective is to design and manufacture a contactless dispensing valve to avoid curing and rapid hardening of the adhesive/high viscosity fluids, using pinching effect between the flowing fluid and the tube in contact. Validation of this design is done through analysis. The methodology to achieve this objective will be first to define the problem definition. After defining the problem, the literature survey is done on various methods that are already in market and a detail study on the solution or the way to achieve the solution. Design of the valve is done based on the pinching effect. Model is prepared in SolidWorks software and analysis is done in Ansys software. Testing of the valve is the most crucial part for the valve to sustain the design and the parameters. The expected outcome from this paper is to design and manufacture a valve for high viscosity fluid to flow with high pressure and without any curing, metal life will be increased because there is no contact between metal and the fluid. Due to the pinching effect used, the wastage of fluid will be avoided

**Keywords:** Curing, Dispensing, Pinching effect, Pinch valve, Rapid hardening.

## I. INTRODUCTION

Valves are the components in a fluid flow or pressure system that regulates either the flow or the pressure of the fluid. A component for controlling the passage of fluid through a cylinder, duct or nozzle, especially an automatic device to allow movement in one direction only. The work of valve may involve stopping and abling flow, controlling flow rate, diverting flow, preventing back flow, controlling pressure, or relieving pressure. The demand of pinch valves in Pulp and paper, mining and power sector is ever increasing in growing economies like India.

**Revised Manuscript Received on July 05, 2019**

**Pavankumar Ravindra Sonawane**, assistant Professor in Mechanical Engg. department at D Y Patil Institute of Engineering & Technology Ambi, Pune.

**Dhirajsingh Bhagatsingh Bhakuni**, Undergraduate scholar, Department of Mechanical Engg., D Y Patil Institute of Engg. & Technology.

**Nilesh Rajitkumar Dubey**, Undergraduate scholar, Department of Mechanical Engg., D Y Patil Institute of Engg. & Technology.

**Harsh Deepak Joglekar**, Undergraduate of Mechanical Engg., D Y Patil Institute of Engg. & Technology.

**Aniket Bajarang Jawale**, Undergraduate scholar, Department of Mechanical Engg., D Y Patil Institute of Engg. & Technology

Pinch valves used for fluids employ a device that direct contacts process tubing. Major components of a pinch valve A pinch valve may be the best type of valve for flow control application if the operation temperature is within the limit of the polymer. A pinch valve is a type of control valve which uses a pinching effect to obstruct fluid flow. consist of body and a sleeve. The sleeve will contain the flow media and isolate it from the environment, generally used for slurries or processes with entrained solids, because the flexible rubber sleeve allows the valve to close drop tight around solids. The sleeve material can be selected upon the corrosiveness and abrasiveness of the flow media, a suitable synthetic polymer can be chosen. Contact Dispensing - In contact dispensing, the drop forms at the exit of a nozzle, and is deposited by contact, while the drop is still on the nozzle. Unlike non-contact dispensing, contact dispensing requires Z-axis movement to bring the valve very close to the surface of the workpiece to dispense. It also often requires a dispense tip fastened to the fluid body. A wider range of fluids can be dispensed via the contact dispensing method, though not within as strict deposit tolerances. There is a reduced risk of deposit satellites and splashing. Set-up and training are relatively quick and easy. The advantage of contact dispensing is that it is widely used in industries and is well established, also it is easily available in market Non-Contact Dispensing - There is no metal contact inside the valve during or after dispensing of material. In noncontact dispensing, the drop also forms at the end of a nozzle, but far enough away from the target area that the drop separates from the nozzle before it hits as well.

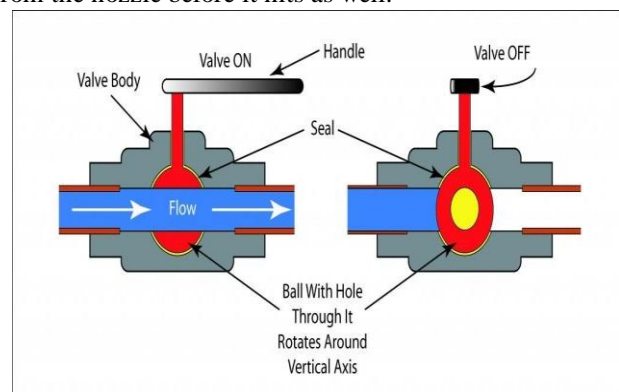

Fig 1 - Contact dispensing valve

# Design & Development of Contactless Valve for Adhesive Fluid Flow

## A. Problem Statement

Contact dispensing is far more effective and simpler method for low viscosity fluids but brings a lot of problems and restriction when higher viscosity fluids are considered. The problem that arises with contact dispensing when higher viscosity fluids are considered is with the opening and closing mechanism of the valve, the accumulation of the flowing fluid, restriction to fluid flow and this all add up to reduce the life of the valve.

## B. Objective

- Design of Non-Contact dispensing valve.
- To avoid curing and rapid hardening of adhesives i.e. Contact with air or metal parts is avoided.
- Validation of design through analysis

## C. Scope

Various parameters considered are

- Material used for flow – EPDM tube (Ethylene propylene diene monomer)

sSr. No.	Material	Density	UTS
1	Aluminum HE30	2.71 g/cm <sup>3</sup>	140 to 330 MPa
2	StainlessSteel 1 (EN303)	8 g/cm <sup>3</sup>	415 MPa
3	Titanium	4.45g/cm <sup>3</sup>	434 MPa

- Tube diameter – 11.5 mm
- Flowing fluid – Fevicol
- Viscosity – 200 to 300 poise
- Flowing pressure – 1 atm
- Actuating technique – Pinching effect
- Actuating pressure – 3 bar

## II. LITERATURE REVIEW

Adhesive dispensing and its flow control is a great challenge in front of industries these days. This research project particularly focuses on the development of a non- contact type dispensing valve for adhesive dispensing so as to eliminate the direct contact of adhesive material and valve body with air or metal.

1. Prasad et. al elaborated about the selection of appropriate mechanism for our non-contact valve. This made our vision clear about the idea & technology available in the market and what we have to implement to achieve the goal of cutting the contact between the flowing fluid inside the valve and the valve body. Pinch valve mechanism is a flow control and shut-off valve, used for slurry & adhesive flow application where abrasive or corrosive, powders, or granular substances are present. Sleeve is the critical and replaceable part in

the pinch valve which increases the life of the valve. The design and optimization of sleeve is difficult for mining applications. Pinching force is needed to design manual, pneumatic and hydraulic actuators. The pinching result forces which is coming from the composite sleeve, while pinching is calculated by simulations. The operating conditions are internal pressure and pinching movements. Composite sleeve is the composition of rubber and nylon fabric, we optimized the composite sleeve thickness and number of fabric layers required to withstand the operating pressure and pinching movements.[1]

2. DOE-HDBK handbook elaborated basic Parts and Components in general purpose Valves, used for flow control of Water and medium viscosity fluids. This helped us in understanding the basic layout of a Valve and flow control mechanisms. This handbook includes information on diesel engines, heat exchangers, pumps, valves, and miscellaneous mechanical components. This information will provide personnel with a foundation for understanding the construction and operation of mechanical components that are associated with various DOE nuclear facility operations and maintenance.[2]
3. Tandle et. al helped us in knowing the mechanism of the contact type dispensing valve. The design and analysis of trunnion mounted ball valve. The project work consist of verification of design of ball component of ball valve. Also the verification of design body and ANSI pressure rating of 900 class gear operating full port type operating in water media. According to the result comparison if required the design changes suggested to the manufacturer. As the valve shows good performance in valve test it can be conclude that the design verification of ball, body & steam components is achieved through numerical calculation, analysis and experiment. [3]
4. Bammesberger et. al from this paper we studied the working, design and analysis done for a non-contact solenoid dispensing valve and helped us to focus on was studied using the respective graphs plotted in the paper. The dispensing volume was determined experimentally and no. of iteration were carried out.[4]
5. Mandanaka et. al Since there is no particular design and analysis procedure for a non-contact type dispensing valve, hence a lot of the research work, design procedure, parameters to be set for the project, limitation, these all things are studied with regards to the existing contact type dispensing valve procedures. This paper helped us understand the life cycle of valve, material selection parameter with respect to the wear and bearing capacity of the valve body and wear etc.



The mechanical and chemical properties of the valve were also studied in this paper which helped us considered our properties. The FEA procedure done for a contact valve was studied and later on applied in our project.[5]

### III. MATERIAL SELECTION

Valve shells (bodies and bonnets) are usually manufactured from a combination of castings and/or forged or wrought components. The castings are made by pouring molten metal into a mold or pattern of the appropriate shape. The parts are then removed from the mold, cleaned up and machined as necessary. The forging process creates a component by shaping a red-hot piece of metal under high pressure in a forging press. This process yields parts that are free from the defects that often plague metal castings such as shrinkage and porosity. Wrought components are those that have been intensely rolled or squeezed through a mandrel, sometimes at room temperature and sometimes at very high temperatures. In valves, wrought components, which are usually round in shape, are found most often in stems or spindles. As cousins to forgings, wrought components also are devoid of the defects that often are found in castings. You might wonder, if forgings and wrought components are so great, then why aren't they used in all valves? The answer is simple—cost. Castings are much cheaper to produce than forgings. In a world where money is no object and ultimate quality is the only goal, all valves would be forged. But the casting process usually achieves the desired ratio of strength to cost, although defects inherent in the casting process have to be considered. As aluminum is light in weight and high weight to strength ratio, so is compatible for our valve body design. Various parameters were also taken into account such as cost, availability, etc

### IV. DESIGN CALCULATION

The EPDM tube diameter is considered 11.5mm  
The pressure to be generated for actuating the spring is between the outer body and the divertor so, inner diameter of outer body = 37mm  
Outer diameter of divertor = 24.5mm  
Actuating pressure is considered = 3bar  
Hence the force required to actuate the spring,  
 $F = P \times A$   
 $F = (3/4) \times \pi \times ((0.037)^2 - (0.0245)^2) \times 10^5$   
 $F = 181.1324 \text{ N}$   
This is the actuating force for the spring and also the force acting on outer body  
Now calculating spring parameters,  
As the spring is rested on the divertor so its mean diameter will be  
 $D1 = 37\text{mm} \ \& \ D2 = 24.5\text{mm}$   
 $D = (D1 + D2)/2$   
 $D = (37 + 24.5)/2$   
 $D = 30.75\text{mm}$   
We take spring of helical flat and grounded end, material of spring is panted and cold drawn unalloyed steel which is having tensile strength of 1570 N/mm<sup>2</sup>  $S_{yt} = 1570 \text{ N/mm}^2$   
 $G = 75490 \text{ MPa}$

And we assume spring diameter,  $d = 4\text{mm}$  and deflection  $\delta = 18\text{mm}$

Spring stiffness is,

$$k = P / \delta$$

$$k = 181.132/18$$

$$k = 10.0623 \text{ N/mm}$$

Number of turns is,

$$N_a = (Gd^4)/(8D^3k)$$

$$N_a = (75490 \times 4^4)/(8 \times 30.75^3 \times 10.0623)$$

$$N_a \approx 9 \text{ turns}$$

Since the spring is grounded end,

$$N_t = N_a + 1$$

$$N_t = 9 + 1 = 11 \text{ turns}$$

Spring index is,

$$C = D/d$$

$$C = 30.75/4$$

$$C = 1.14108$$

Wahl factor is given by,

$$K = \frac{4C - 1}{4C - 4} + \frac{0.615}{C}$$

$K = 1.101$  Permissible shear stress is,

$$\tau = K \left( \frac{8 \times P \times D}{\pi D^3} \right)$$

$$\tau = 2229.97 \text{ N/mm}^2$$

Therefore tensile strength is,

$$S_{yt} = \tau/2$$

$$S_{yt} = 1321.46 < 1570 \text{ N/mm}^2$$

Therefore, spring doesn't fail.

Pitch calculations,

$$L = N_a \times P + 1.5d$$

$$29.5 = 9 \times P + 1.5 \times 4$$

$$P = 2.944\text{mm}$$

### V. 3D MODELING USING CAE

3D modelling of the valve body was done using the software SolidWorks and detailed dimension study and analysis were carried out of the valve mechanism in both the condition open and close condition. The CAD software helped us know that our design was precise and errors build up while designing were rectified. Since no particular procedure is given for design a non-contact valve, the concept was build up around the pinch valve mechanism and how to contain it. We decide a certain pressure for actuation of the valve and with respect to that pressure the remain parts were designed. This concept had very inter-related design and the software helped us knowing them correctly. The figure shows the complete assembly of the valve body



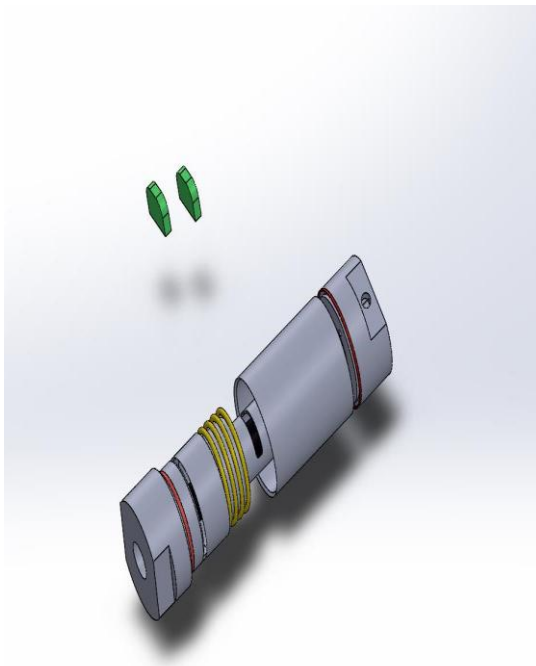

Fig 2- Final assembly of valve body

## VI. FEA ANALYSIS

FEA analysis on the various parts of valve body was carried out to know the area where the stress concentration will occur, the deformation due to pressure, strain acted on the parts due to the etc. were determined using the ANSYS software. The actuating pressure is considered as 0.3MPa or 3 bar pressure hence the pressure force of 3 bar was acted on the various surfaces and this was the only parameter considered for the first stage analysis of the valve body. The diagrams below illustrates the various critical part of the valve body under stress. The factor of safety calculated by these analysis came out to be very high under operating conditions of the valve

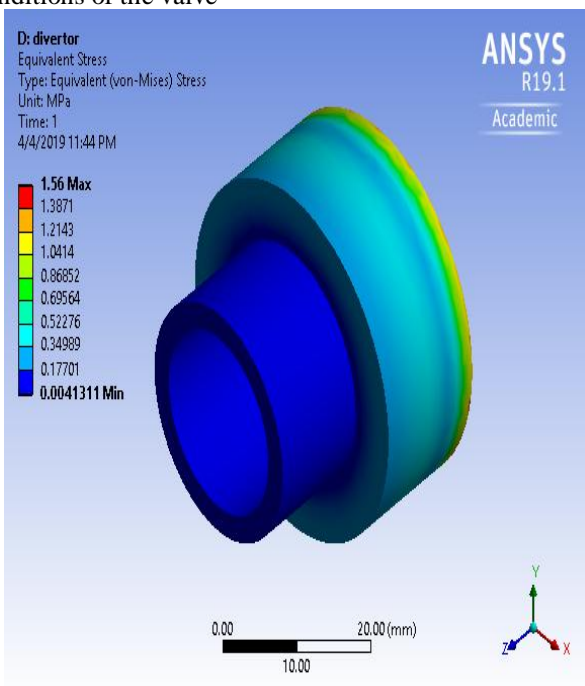

Fig 3 - Equivalent stress on diverter

The force of 181N was applied on the face connected to the metal bush and a retracting force of 181N for which the spring was designed is applied on the other face of the diverotr.

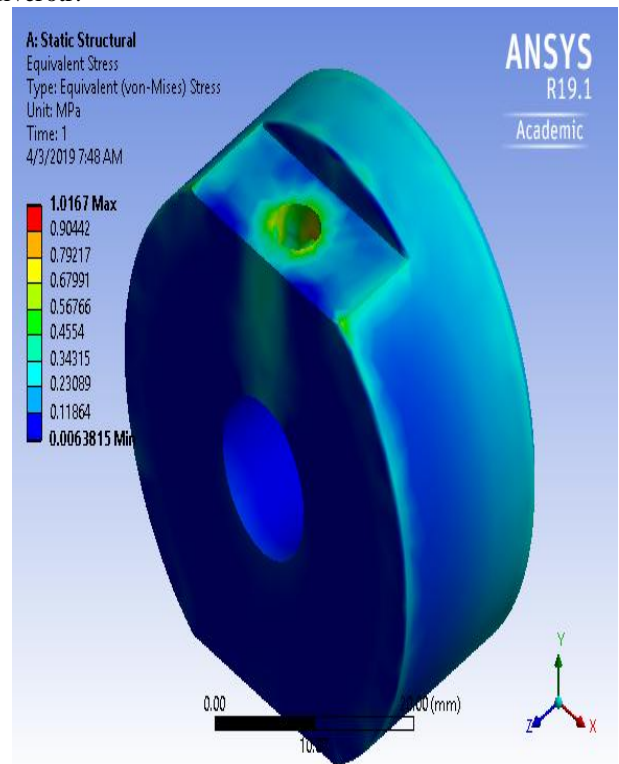

Fig 4 - Equivalent stress on end cap

For the endcaps the inlet nozzle was applied to normal pressure of 3bar and the inner face of the endcap was given an incident force of 181N coming from the return action of the metalbush

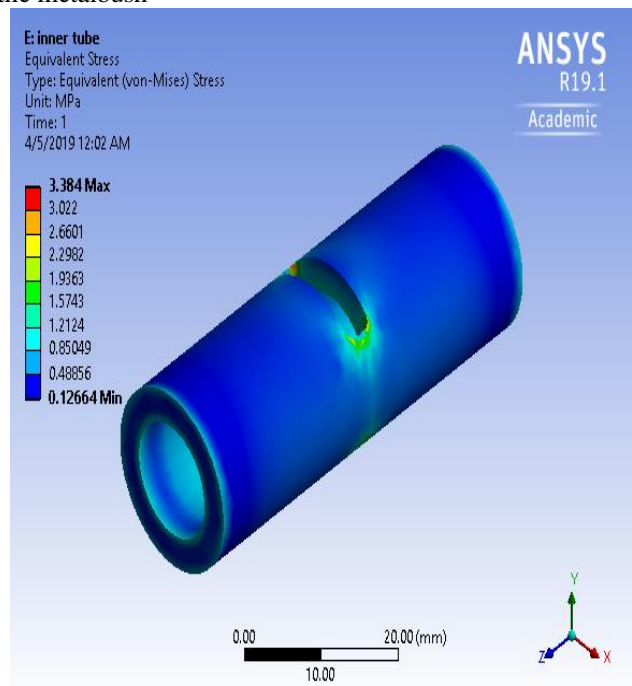

Fig 5 - Equivalent stress on inner tube

Inner tube was only acted by the pressure inside the valve hence it was given a normal pressure of 3bar for.

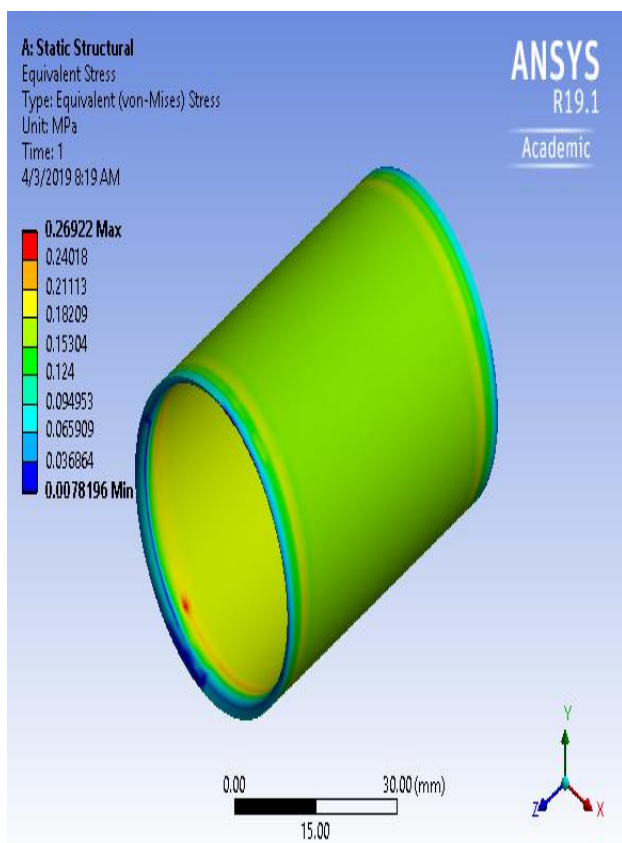

Fig 6 - Equivalent stress on outer body

## VII. MANUFACTURING OF THE COMPONENTS

All the parts were manufactured in our college workshop. The parts were machined on the conventional lathe machined and the tools used were single point cutting tool, parting tool, boring tool. Various drill bit were also used to reduce the boring time of sizes 12,16,24 mm diameters. Special boring tools were also made to bore diameters which were very for the conventional boring tool to work. The spring was the only component that was outsourced. Neelkamal spring & engineering helped us providing the spring according to our design needs. The manufactured components are shown below.



Fig 7 - Manufactured components

## VIII. CONCLUSIONS

- 2D Design for each part and complete assembly was done using 3-D model software SolidWorks.
- From the FEA analysis done on the respective components on ANSYS software we determined our components are failure proof under the operating pressure.
- The Factor of Safety is high hence the component will not fail under high load conditions.
- Leak proofing was insured by installing proper seals and accurate machining, this also helped in avoiding contact of air with adhesive material and to make entire assembly air tight

## REFERENCES

1. Raghu Prasad T. V., Uday Kumar Painter and Laxmi Narayan, "Composite Rubber Sleeve Analysis of Pinch Valve Using Radioss FE Package". HTC 2010.
2. Pidilite industries limited technical data sheet.
3. Mr. Swapnil B. Tandle, Prof. Milind Ramgir, "Design & Analysis of Trunion Mounted Ball Valve" International Journal of Science, Engineering and Technology Research (IJSETR) Volume 5, Issue 9, September 2016
4. Stefan Borja Bammesberger et. al "A Low-Cost, Normally Closed, Solenoid Valve for Non-Contact Dispensing in the Sub- $\mu$ L Range" micromachines ISSN 2072-666X, 2013.
5. Parth Mandanaka & Prof. Hitesh Raiyani, "Review on Modeling and FEA Analysis of Ball Valve" IJSRD - International Journal for Scientific Research & Development, Vol. 4, Issue 03, 2016, ISSN (online): 2321-0613
6. P. R. Sonawane, S. A. Walavalkar, "Design of Finger and Thumb Mechanism for Prosthetic Arm." International Review of Mechanical Engineering (IREME), Vol. 11, No. 7, (460-466) July 2019.
7. Pavankumar Ravindra Sonawane, M Chandrasekavan, "Investigation of Gear Pitting Defect using Vibration Characteristics in a single stage Gearbox." International Journal of Electrical Engineering Education, P.P. (1-7), 2018.
8. U. A. Gaikwad, P. R. Sonawane, R. B. Pawar, "Photo-Elastic Investigation of Worm Gear." International Review of Mechanical Engineering (IREME) Vol.11, No. 6, June 2017.

## AUTHORS PROFILE



**Pavankumar Ravindra Sonawane** is working as assistant Professor in Mechanical Engg. department at D Y Patil Institute of Engineering & Technology Ambi, Pune. He obtained M.E. with specialization Design Engineering from North Maharashtra University, Jalgaon. His research areas are design, condition monitoring and fatigue. He has 10 years of teaching experience in various subjects of Mechanical Engineering. He has been awarded as "Best Teacher Award" at D Y Patil Technical Campus in year 2014-15.



**Dhirajsingh Bhagatsingh Bhakuni**, Undergraduate scholar, Department of Mechanical Engg., D Y Patil Institute of Engg. & Technology

## Design & Development of Contactless Valve for Adhesive Fluid Flow



**Nilesh Rajitkumar Dubey**, Undergraduate scholar, Department of Mechanical Engg., D Y Patil Institute of Engg. & Technology.



**Harsh Deepak Joglekar**, Undergraduate of Mechanical Engg., D Y Patil Institute of Engg. & Technology.



**Aniket Bajarang Jawale**, Undergraduate scholar, Department of Mechanical Engg., D Y Patil Institute of Engg. & Technology