

# Lateral load analysis of Retrofitted Masonry wall using Steel strips and Poly Propylene fiber

Theerkadharshini.S, Felix kala.T

**Abstract:** Masonry is widely used type of construction in the world. But these walls are built with no seismic loading requirements and they are not capable of dissipating energy through inelastic deformation during earthquake. Recent earthquakes have shown that many such buildings are seismically vulnerable and should be considered for retrofitting. To prove the efficiency of retrofitting of masonry structures, this thesis deals with an Experimental programme to ascertain the compressive and shear strength enhancement of masonry wall panels using steel strips and polypropylene fibre. The study includes six wall panels, three each for compressive and shear strength evaluation. In each of three walls, one wall is unreinforced masonry wall, the second is reinforced on both sides with diagonal steel strips and the third is reinforced with closely spaced polypropylene mesh. Separate testing arrangements we made for compressive and shear strength tests. During compressive testing only vertical load is applied and for shear strength determination, lateral load with vertical pre-compression is applied. During the test, observations we recorded covering all important parameters like ultimate compressive load, shear strength, deflection due to compressive and lateral loads and behaviour of steel strips under vertical and horizontal loading. Load carrying mechanisms are observed, varying from the initial, uncracked state, to the final, fully cracked state. The results demonstrate that a significant increase in compressive and shear strength can be achieved by anchoring strips and polypropylene fibre to the surface of masonry wall.

**Keywords—** Retrofitting, Earthquake, Vertical precompression, Anchoring strips, Polypropylene fibre

## I. INTRODUCTION

To know the retrofitting techniques and materials through literature collection and to find the shear and compressive strength of the Unretrofitted and retrofitted wall using steel strips and polypropylene fibre. Masonry is one of the oldest and widely used type of construction materials in the world. Advantages of masonry are aesthetics, architectural appearance, effective heat and sound insulation resistance and economical construction. Most of these walls are built with no seismic loading requirements, and they are not capable of dissipating energy through inelastic deformation.

The main purpose of retrofitting the masonry buildings is to improve its performance in earthquakes, increase the strength and/or stiffness, ductility and thus to reduce the loss of life during earthquake.

Revised Manuscript Received on July 05, 2019.

Theerkadharshini.S, Research Scholar, Department Of Civil Engineering,(Dr. M.G.R. UNIVERSITY), Panimalar Engineering College Chennai, India

Dr. T.felixkala, Professor, Department Of Civil Engineering Dr. M.G.R. Educational And Research Institute University Chennai, India

## II. RETROFITTING TECHNIQUES.

There are several methods available for retrofitting, they are

### A. Surface treatment

By nature this treatment covers the masonry exterior and affects the architectural or historical appearance of the structure.

- 1) Ferro cement: Ferro cement consists of closely spaced multiple layers of hardware mesh of fine rods.

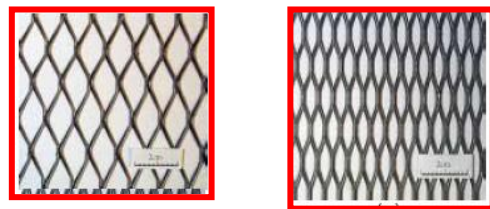

fig1.Hardware samples used in ferro cement.

- 2) Reinforced plaster: A thin layer of cement plaster applied over high strength steel reinforcement can be used for retrofitting.

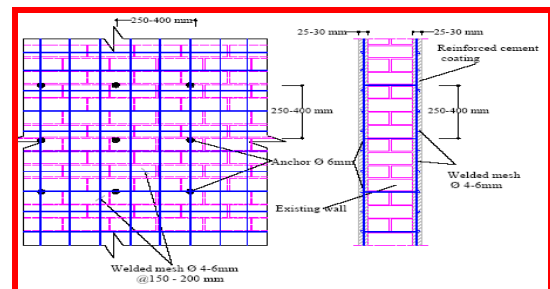

Fig2-reinforced plaster typical dimension

- 3) Shotcrete: Shotcrete overlays are sprayed onto the surface of a masonry wall over a mesh of reinforcing bars of 6-13 mm diameter @ 25-120.



Fig3-shotcrete method.

# Lateral load analysis of Retrofitted Masonry wall using Steel strips and Poly Propylene fiber

## B. Grout and epoxy injection.

Epoxy resin is used to inject for relatively small cracks (less than 2 mm wide); while, cement-based grout is considered more appropriate for filling of larger cracks, voids.



Fig 4-grout injection.

## C. External reinforcement.

A steel plates or tubes can be used as external reinforcement for existing UnReinforced Masonry buildings.

## D. Confining UnReinforced Masonry using RC tie column.

Confined masonry with R.C. weak frame represents one of the most widely used masonry construction system

### III. REINFORCING MATERIALS

1. Fibre Reinforced Polymer (FRP).
2. Carbon Fibre Reinforced Polymer (CFRP).
3. Glass Fibre Reinforced Polymer (GFRP).
4. Steel Strips.
5. Polypropylene Fibre.

## A. Reasons for choosing the above materials.

CFRP gives good results while used in the diagonal manner, To know the results of steel strips in diagonal manner and to know the strength of polypropylene fibre under compressive and shear load.

### SPECIFICATIONS

Table I – Description of the specimen.

Type of specimen	Specification		
	Size of specimen	Compressive strength	Cement sand ratio
Unretrofitted wall	2'6"x2'6"	7N/mm <sup>2</sup>	1:6
Retrofitted with diagonal strips on both sides	2'6"x2'6"	7N/mm <sup>2</sup>	1:6
Retrofitted with polypropylene	2'6"x2'6"	7N/mm <sup>2</sup>	1:6

Table II – Size of the retrofitting materials.

Type of specimen	Specification	
	Size of retrofitting materials	Type of anchoring
Unretrofitted wall	-	-
Retrofitted with diagonal strips on both sides	Galvanized MS of 40mm x 1.2mm	40mm long bolt with 6mm dia along with washer

Type of specimen	Specification	
	Size of retrofitting materials	Type of anchoring
Retrofitted with polypropylene	16mm x 1mm	1" nails are used to anchor the mesh

### NOMENCLATURE AND TESTING

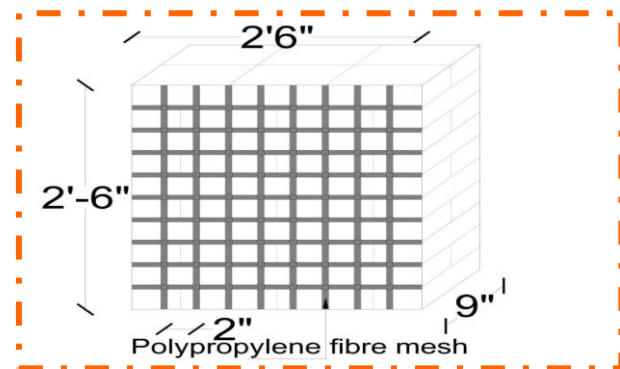
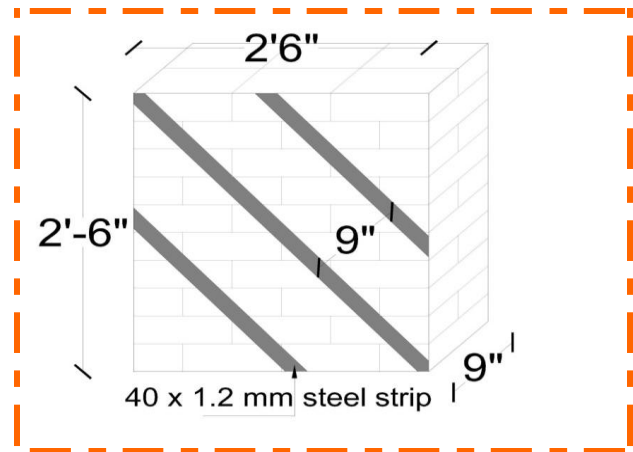

### Testing arrangements and testing results.

#### ➤ compressive testing arrangement for wall

A vertical in-plane compressive load is applied to all the three wall. The vertical load is applied through connected hydraulic jack and the proving ring is attached along the jack to measure the applied load. Distributed over the top of the specimen by a Hollow rigid steel beam resting on the surface of the wall. Three deflection gauges are attached at vertical centre of the masonry wall panel to calculate the buckling of the wall under vertical load. Two DIMMIC points each in both face of steel strips are attached to the steel strips to measure the strain value. Strain values are calculated from the reading taken from DIMMIC gauges.

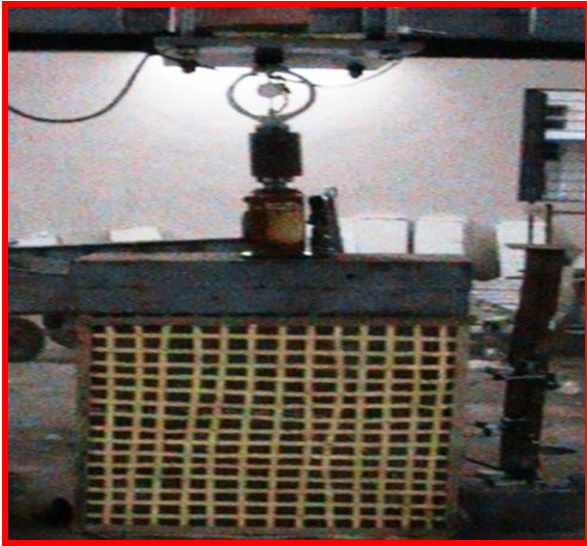

➤ Shear compressive strength arrangement.

A combination of vertical load (simulating load from the building above) and in-plane shear lateral load was applied to all the three specimens. The vertical pre-set load of 5 ton is applied through hydraulic jack. The shear load is applied to the wall by a horizontal jack and the proving ring is attached along with the jack to measure the applied load. The horizontal deflection is measured using a deflection gauge at the same level as the lateral load application point. DIMMIC points are attached with steel strips in diagonal direction to measure the strain value of strips under lateral load.

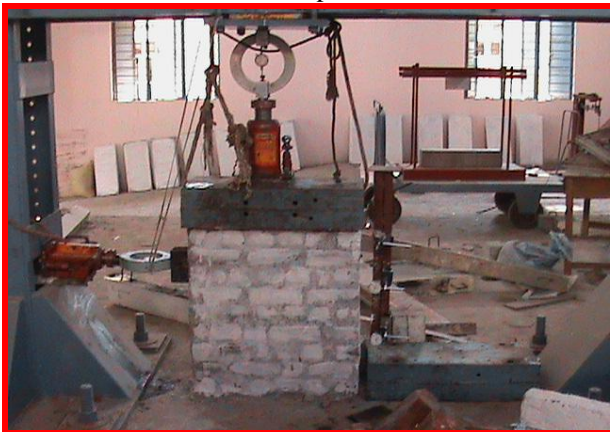

Table III – Test results of specimen under compressive load

Test results	Unreinforced wall	Diagonally strengthened with steel strips	Polypropylene fibre
Compressive strength (tons)	10.5	16.8	14.2
% age increase	-	37.50	26.32
Compressive stress (KN/m <sup>2</sup> )	62.79	100.48	84.92
Steel strain in diagonal direction	-	0.000367	-
Deflection due to compressive load (mm)	12.98	18.56	13.63

Table IV-Readings for deflection due to compressive load in the middle of the walls

URM wall		Steel strips wall		Polypropylene wall	
Load (K)	Deflection (mm)	Load (KN)	Deflection (mm)	Load (KN)	Deflection (mm)

N)					
0	0	0	0	0	0
10	0.48	10	0.22	10	0.34
20	0.98	20	0.3	20	0.57
30	1.93	30	0.45	30	0.78
40	2.68	40	0.58	40	0.98
50	3.56	50	0.89	50	1.56
60	3.92	60	2.46	60	2.55
70	4.06	70	2.88	70	3.08
80	4.67	80	3.52	80	3.95
90	4.89	90	4.75	90	5.46
100	5.26	100	6.15	100	5.78
		110	7.92	110	6.89
		120	8.45	120	7.45
		130	8.78	130	7.89
		140	9.1	140	7.98
		150	9.54		
		160	10.93		
		170	11.65		

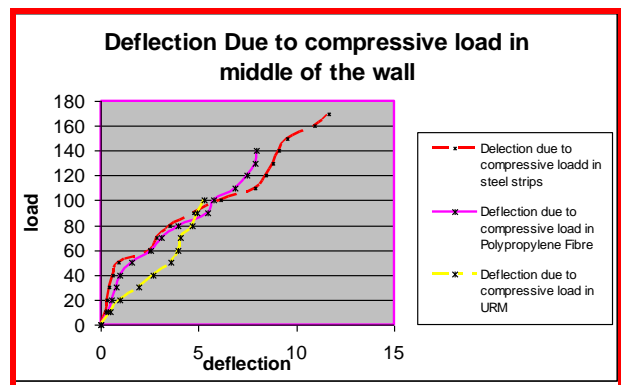

Fig -5

#### IV. FAILURE PATTERN

Minor cracks appeared at vertical load of 7 tons corresponding to a compressive stress of 40.18 kN/m<sup>2</sup>. This cracks caused the crushing of bricks along fourth wythe and completely collapsed at a vertical load of 10.5 tons.



Minor cracks appeared at 13 tons corresponding to the compressive stress of 74.37 kN/m<sup>2</sup>. The plane of failure is along the second wythe extending from right to centre as shown in figure. The failure is not sudden and good composite behaviour is observed due to presence of steel strips.

# Lateral load analysis of Retrofitted Masonry wall using Steel strips and Poly Propylene fiber



Minor cracks appeared at vertical load of 9 Tons corresponding to a compressive stress of 51.48 kN/m<sup>2</sup>. The plane of failure is along the third wythe extend to the bottom of the wall. The failure is not sudden and good composite behavior is observed due to presence of polypropylene fibre.

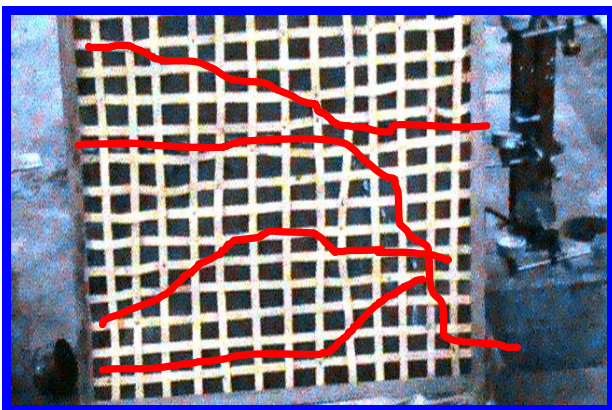

Table V- Details of shear test results

Test results	Unreinforced wall	Diagonally strengthened with steel strips	Polypropylene fibre
Shear strength (tons)	3.5	6.8	4.43
% age increase	-	48.53	21
Lateral displacement at top (mm)	12.98	18.6	15.02
Lateral displacement at middle (mm)	8.32	11.68	13.63
Lateral displacement at bottom (mm)	6.24	9.03	8.52
Steel strips in diagonal direction	-	0.0011	-

Table VI- Readings for deflection due to Shear load in the TOP of the walls

Steel strips wall		Polypropylene wall		URM wall	
Load (KN)	Deflection (mm)	Load (KN)	Deflection (mm)	Load (KN)	Deflection (mm)
0	0	0	0	0	0
5	0.38	5	0.65	5	0.78
10	0.76	10	1.98	10	1.58
15	1.78	15	3.7	15	2.65

20	3.79	20	5.2	20	4.98
25	5.67	25	7.03	25	6.79
30	7.58	30	8.62	30	10.76
35	9.53	35	10.1	35	12.98
40	10.5	40	12.07		
45	12.53	45	13.63		
50	13.76				
55	14.45				
60	15.28				
65	17.45				
70	18.56				

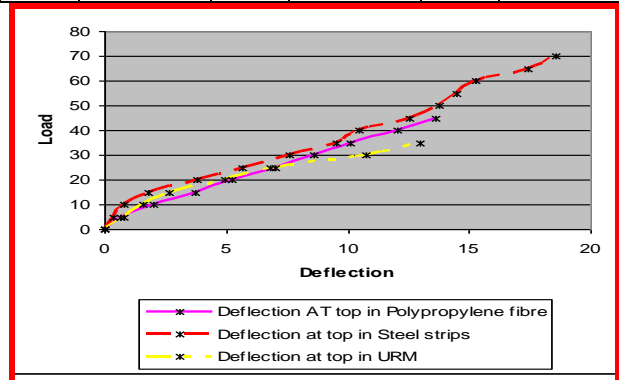

Fig-6 load and deflection graph for shear load on wall at top

Table VII- Readings for deflection due to Shear load in the middle of the walls

Steel strips wall		Polypropylene wall		URM wall	
Load (KN)	Deflection (mm)	Load (KN)	Deflection (mm)	Load (KN)	Deflection (mm)
0	0	0	0	0	0
5	0.42	5	0.6	5	0.75
10	1.18	10	1.62	10	1.75
15	2.12	15	3.92	15	3.89
20	3.06	20	4.98	20	4.8
25	3.94	25	6	25	5.24
30	4.92	30	7.93	30	7.45
35	5.97	35	8.98	35	8.32
40	6.7	40	10.18		
45	8.54	45	11.68		
50	10.44				
55	11.52				
60	13.36				
65	14.41				
70	15.02				

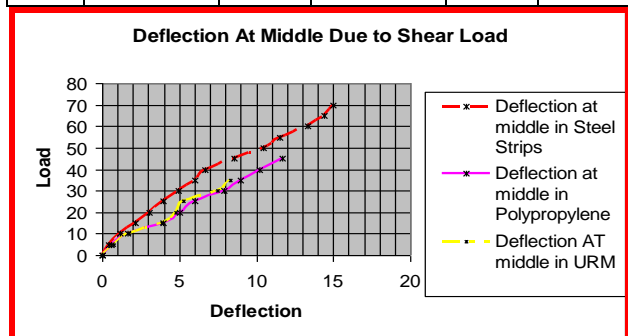

Fig-7 load and deflection graph for shear load on wall at middle

Table VIII- Readings for deflection due to Shear load in the bottom of the walls

Steel strips wall		Polypropylene wall		URM wall	
Load (KN)	Deflection (mm)	Load (KN)	Deflection (mm)	Load (KN)	Deflection (mm)
0	0	0	0	0	0
5	0.24	5	0.27	5	0.85
10	0.97	10	0.78	10	1.08
15	1.62	15	1.46	15	2.74
20	2.24	20	2.18	20	3.78
25	2.74	25	3.58	25	4.79
30	4.64	30	4.98	30	5.12
35	5.04	35	6.23	35	6.24
40	7.09	40	7.13		
45	9.09	45	8.52		
50	9.52				
55	10.76				
60	11.32				
65	11.56				
70	11.67				

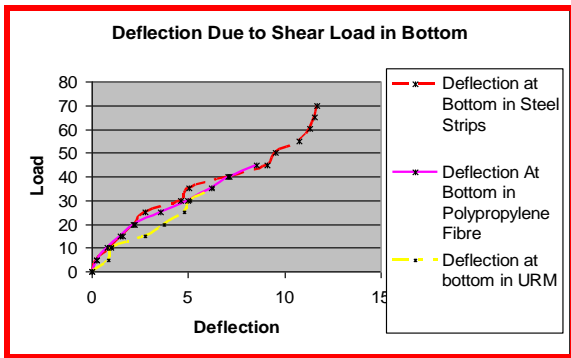

Fig-8 load and deflection graph for shear load on wall at bottom

### V. SHEAR FAILURE OF MASONRY WALL

In URM panel cracks appeared at left edge of fifth wythe and sliding along horizontal plane and extends to the bottom of the right end of the wall. Cracks appeared from load application point and extending towards the right bottom edge. The failure is not sudden and good composite behavior is observed with sufficient strength due to presence of steel strips. Cracks appeared which are initiated from bottom of load application point and extending towards the right bottom edge. The failure is not sudden and good composite behavior is observed with sufficient strength due to presence of polypropylene fibre mesh.

### VI. CONCLUSION

From the results of Experimental works, significant increase in compressive and shear strength can be achieved by anchoring steel strips and polypropylene fibre to the surface of the wall. The technique approach is viable for rehabilitation of old deteriorating building and strengthening of unreinforced masonry structures in seismic zones.

### REFERENCES

1. Ciro faella, Enzomartinelli, Emidionigro, and Sergio Paciello., Auguat 1-6,2004, "Tuff masonry walls strengthened with a new kind of CFRP sheet: Experimental Test and Analysis".13<sup>th</sup> World Conference on Earth quake Engineering Vancouver, B.C., Canada.

2. Ehasani.M.R, Fellow, ASCE, Saadatmanesh.H, Member, ASCE, and Velazquez-Dimas .J.I, August 1999."Behaviour of retrofitting URM walls under simulated earthquake loading", Journals of Composites for construction.
3. Elgawady.M, Lestuzzi.P, and M.Badoux., july4-7,2004,"A Review of conventional seismic retrofitting techniques for URM".13<sup>th</sup> international Brick and Block masonry Conference Amsterdam.
4. Farooq S.H, Ilyas.M and.Ghaftar.A., 2006,"Technique for Strengthening of masonry wall panels using steel strips",Asian journal of civil engineering (BUILDING AND HOUSING) VOL.7,NO.6. I.S.
5. Hernan Santa Maria, Pablo Alcaino, and Carl Luders., April 18-22,2006, "Experimental Response of Masonry Walls Externally Reinforced With Carbon Fiber Fabrics", Proceedings of the 8<sup>th</sup> U.S National Conference on Earthquake Engineering ,San Fransisco,California,USA.
6. Mahmood.H, Russell A.P, and Ingham J.M., "Laboratory testing of unreinforced masonry walls retrofitted with glass fiber reinforced polymer sheets",Department of civil and Environmental Engineering, heUniversity of Auckland,New Zealand.
7. Manzouri.T,Schuller.M.P,Shing.P.B, and Amadei.B,"Repair and Retrofit of unreinforced masonry structures", Department of civil Engineering., University of Colorado, CO 80309-0429,ETATS-UNIS.
8. Mustaaq Taghdi, Michel Bruneau, and murat saatcioglu., 2000., Seismic retrofitting of low -rise masonry and concrete walls using steel strips", Journals of structural Engineering September.
9. Wayne Ruth and Michael Schuller "Masonry Repair by Grout injection".
10. "Masonry Wall Strength Assessment And Retrofit Options ", Hurricane Retrofit Guide-Masonry wall strength.

### AUTHORS PROFILE



**THEERKADHARSHINI.S,** Researchscholar, Department of civil engineering Dr. M.G.R. Educational and Research Institute, working as Assistant professor in Panimalar Engineering College.



**Dr.T.Felixkala.,** Professor, Dean and research, Department of civil engineering Dr. M.G.R. Educational and Research Institute University, Chennai, India. she has published many articles in International and National Journals. He has guided/guiding several UG, PG and Ph.D. research scholars. His research interest is focused on high performance concrete.

