

# Experimental and numerical analysis of the effect of preheating in friction stir welding

Md. Parwez Alam, A. N. Sinha

**Abstract:** Friction stir welding has been frequently used for fabrication of low melting point materials. Nevertheless, it is capable to join thin sheet of high melting point materials such as stainless steel, titanium etc. but tool wear rate is high. A Heat-assisted backing plate (HABP) was developed to preheating the welded specimen. In this paper, a modified 3D FE model was established to simulate the heat-assisted backing plate of friction stir welding by using ANSYS APDL to study of the temperature distribution of workpiece. Numerical simulation was defined by six different load steps for preheating, plunge, dwell, traverse, pull out of tool and cooling stage. Observations of preheated friction stir welding were compared with traditional friction stir welding results. It was found that the preheated friction stir welding increased 7.39 % and 7.55 % of peak temperature as compared to traditional friction stir welding in FEA and experimental respectively. In addition, preheating improve the uniform temperature distribution along the thickness of welded joint.

**Index Terms:** Friction stir welding, Heat assisting backing plate, Preheating, Numerical simulation, temperature distribution.

## I. INTRODUCTION

Latest generation of Al- Li alloys have considered as a futuristic materials for aerospace and spacecraft due to their inherent properties [1]. However, the joining of these materials by conventional fusion welding is not recommended due to loss of alloying element as well as loss of joint strength. Friction stir welding (FSW) is an ideal joining process for Al-Li alloy. It is a widely growing joining process due to energy efficient, environment-friendly, economically effective and user-friendly operation. It was invented in 1991 by W. Thomas [2]. In the early stage it was used only for the low melting point of materials but gradually it has applied almost all metals. Sound welding dependent on proper thermal management of FSW. It is controlled by selecting proper parameters. Many researchers have been working to enhance the mechanical properties by applying, hybrid processes and various backing plate with different thermal diffusivity and improved tool design.

In hybrid FSW, post weld heat treatment, underwater FSW, in process cooling FSW, and heat-assisted FSW such as laser-assisted FSW, electrical current assisted FSW, electric arc, tungsten arc, induction assisted FSW weld were used to enhance mechanical properties of FSW [3-10]. Santos et al. [11] utilized electrical heat source in the tool probe tip as the additional heat and observed that the additional heat helps in reducing the lack of penetration in root side. Numerous

numerical models have been developed to study the effect of additional heat. Yaduwanshi et al. [12] developed 3D plasma assisted friction stir welding and reported that preheating is beneficial for joining in harder and dissimilar material and reduces the tool wear. Long et al. [13] developed FE model to analyze the electrically enhance FSW to traditional FSW and found similar temperature profile but EHFSW takes half time and they suggested that welding speed can be increased up to double of traditional welding. Shi et al. [14] developed an integrated model to analyze the effects of ultrasonic vibration on tool torque and thermal cycle.

Various backing plate from low thermal conductive material to high thermal conductive materials were applied by many researchers. It is due to most of the heat is transferred from the backing plate. They have reported that low thermal conductivity of back plate such as asbestos, ceramic and composite produces defect-free welding [15-18]. Imam et al. [16] applied mild steel, asbestos and stainless steel as a backing plate and found weld zone temperatures were significantly affected by the BP material and they reported that mechanical and microstructure properties of the joint was the function of backing plate & defect free weld was found with asbestos backing plate. In other observations, Upadhyay et al. [17] found homogeneous temperature distribution along the thickness of workpiece by using low diffusivity of backing plate. Consequently, grain size and hardness was homogenized.

Based on the above literature, a novel approach heat assisting backing (HABP) plate has introduced by considering the importance of additional heating and backing plate. Before welding, the welded material had heated up to 80°C and Compare with traditional welding and numerical modeling in ANSYS APDL is also developed for the same.

## II. EXPERIMENTAL PROCEDURE

In this study, latest generation of Al-Li alloy AA 2099 T8 plate with thickness 5 mm were employed to the friction stir welding process. Welding surfaces were grounded and cleaned with acetone before welding. The plates were kept on modified backing plate as butt configuration and clamped tightly. Fig 1 and fig 2 represent the schematic diagram of heat assisting backing plate and experimental set up of FSW respectively. Friction stir welding was done on BFW Chandra 5 axis CNC vertical milling machine. Three small holes of 1.5 mm diameter and 3 mm depth were drilled from top surface of workpiece at 12 mm, 16 mm and 20 mm from weld line. Thermocouple's wire was connected with 16 channel data scanner to inspect the temperature.

**Revised Manuscript Received on July 05, 2019.**

Md Parwez Alam<sup>\*</sup>, Mechanical Engineering Department, National Institute of Technology, Patna, India.

Amar Nath Sinha, Mechanical Engineering Department, National Institute of Technology, Patna, India.



## Experimental and numerical analysis of the effect of preheating in friction stir welding

The friction stir tool is made of H13 steel. It consist threaded cylindrical pin profile and concave shoulder. The length and diameter of the pin are 4.85 mm and 5 mm respectively. The measured diameter of the shoulder is 18 mm and plunged depth of shoulder is 0.12 mm.

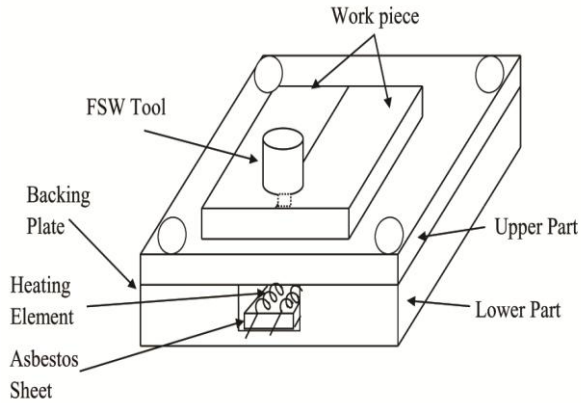

Fig. 1 schematic representation of heat assisting backing plate



Fig. 2 Experimental set up of FSW

### III. COMPUTATIONAL PROCEDURE

Two rectangular plates each of dimension 52 mm × 45 mm × 5 mm were created and meshed. Workpiece was divided into 30 parts along length, 25 parts along width and 3 parts along thickness. In the present analysis, thermal studies were performed near the welding line. Therefore, finer mesh is created along the weld line by considering spacing ratio 5. It is shown in fig 3. The total number of nodes and elements are 8093 and 7989 respectively. A rigid tool, without the pin is created on the weld joint.

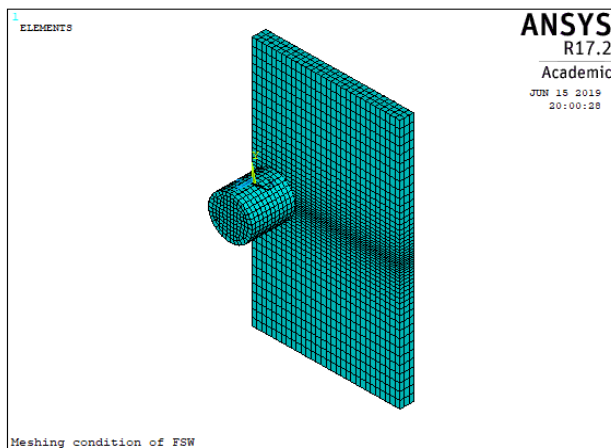

Fig. 3 Meshes of FEM of FSW

Aluminium alloy 2099 T8 is considered for experimental work. So, similar thermo-mechanical properties are specified. For the finite element analysis, the Thermal conductivity, specific heat, density, and the friction coefficient between tool and workpiece are considered as temperature dependent properties as shown in fig 4 and Elastic modulus, poisson's ratio, the coefficient of thermal expansion are considered as temperature independent properties and its value is considered 78 GPa, 0.33, and  $25.2 \times 10^{-6} \text{ } ^\circ\text{C}^{-1}$  respectively. It has also assumed that the workpiece behaves as a rate-independent plastic material.

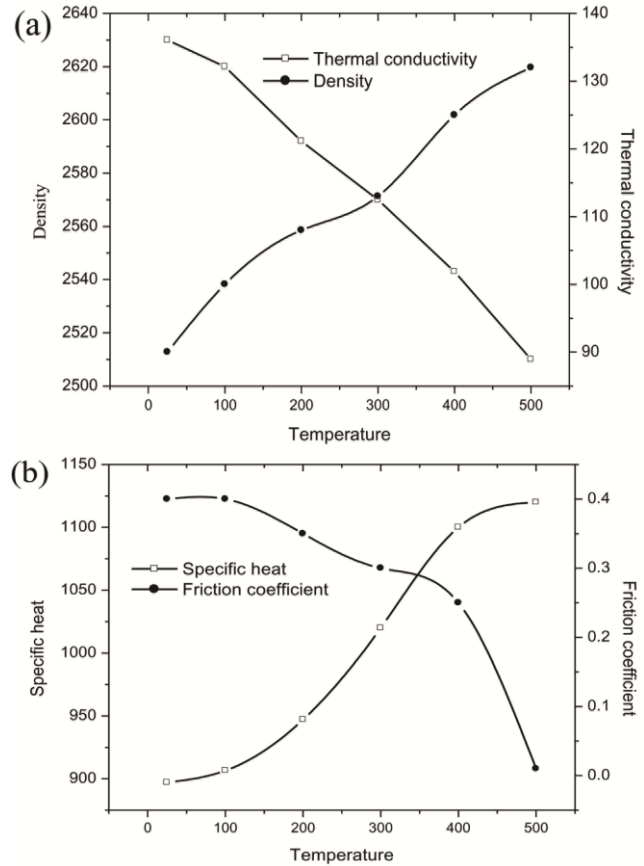

Fig. 4 Temperature dependent material properties of third generation Al-Li alloy [19]

In this analysis, 3D 20 node couple field element SOLID226 was selected because it is capable of large strain capabilities, plasticity, large deflection and stress stiffness [20]. Since, SOLID226 consist mid-side node which can lead (a) oscillation in the thermal solution & (b) nonphysical temperature distribution. Therefore, in this analysis, the mid-side node has removed to avoiding these phenomena. Element CONTA174 and element TARGE170 is used for pair based contact. The bonding temperature between plates has taken  $400^\circ\text{C}$ . It was applied as a real constant TBND for CONTA174. This value shows that when temperature reaches or exceeds  $400^\circ\text{C}$  then the contact type of behaviour changed into bonded type and remains in bonded even though temperature decreases to below the bonding value. Another important real constant thermal contact conductance (TCC) is used between contact interfaces of plates. A high value  $2 \times 10^6$  is taken for perfect conduction of temperature between the plates.

In thermal boundary condition Fourier's law is applied to heat conduction in plate and heat convection is applied for heat loss to ambient and contacting surface. The initial boundary condition for this model is used as

$$T(x, y, z, t) = T_0 \quad (1)$$

Where  $T_0$  is the ambient temperature at time  $t = 0$  and  $T(x, y, z, t)$  represents the transient temperature field  $T$ , which is a function of time  $t$  and spatial coordinate  $(x, y, z)$ . Heat transfer during friction stir welding is a typical nonlinear heat conduction process which is governed by Fourier's law of heat conduction. It is expressed as equation (2)

$$\frac{\partial}{\partial x} \left( K_x \frac{\partial T}{\partial x} \right) + \frac{\partial}{\partial y} \left( K_y \frac{\partial T}{\partial y} \right) + \frac{\partial}{\partial z} \left( K_z \frac{\partial T}{\partial z} \right) + \dot{Q} = \rho C_p \left( \frac{\partial T}{\partial t} \right) \quad (2)$$

Where,  $\rho$ ,  $C_p$ ,  $K$  and  $\dot{Q}$  represents density, Specific heat, directional thermal conductivity and rate of heat generation respectively. In present simulation, only convective heat transfer is considered. The heat loss from free surfaces of workpiece and tool are calculated as equation (3)

$$q = h_{conv} (T - T_0) \quad (3)$$

Where,  $T$ ,  $T_0$  and  $h_{conv}$  refers absolute temperature of workpiece, ambient temperature and convection coefficient of free surfaces of workpiece and tool. Value of heat transfer coefficient for aluminium alloy to air is taken  $30 \text{ W/m}^2$ . Backing plate is always contact with lower surface of workpiece and act as a heat sink. It is found that most of heat is lost through backing plate. For simplicity it is modeled as a convection condition and considered a higher convection coefficient. The value of heat transfer coefficient is taken as  $200 \text{ W/m}^2$ .

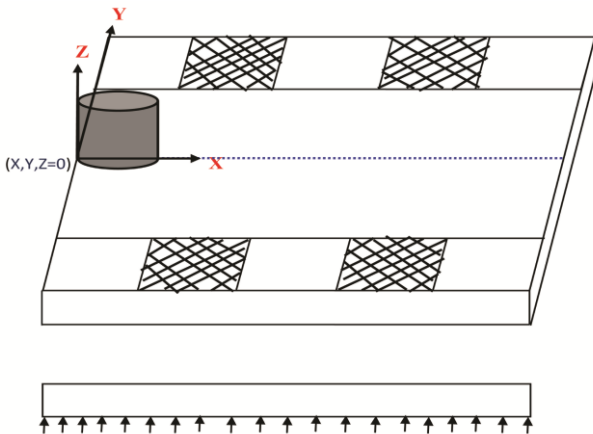

Fig. 5 Thermal and mechanical boundary condition of FSW

The mechanical boundary condition applied as clamping bar on plate and bottom support. The bottom portion of workpiece is constraint in normal direction and taken  $U_z = 0$ . Whereas clamped portion is taken as complete restraint as real i.e. there is no movement in any direction. Boundary condition is represented in fig 5.

Simulation of preheated FSW was defined by six load steps as preheating, plunge, dwell, traverse and pull out of the tool and cooling stage whereas traditional FSW defined by last five load steps. Details of load step depicted in table 1. Newton Raphson technique was utilized to solve the governing non-linear equation and automatic time step is activated for faster solution.

Load steps	Stages	Movement of tool (Preheated FSW)	Movement of tool (Traditional FSW)
1	Preheating stage	No movement	Not applied
2	Plunging stage	Displacement along z-axis	Displacement along z-axis
3	Dwelling stage	Rotation along z-axis	Rotation along z-axis
4	Welding stage	Displacement and rotation along x-axis & z-axis respectively	Displacement and rotation along x-axis & z-axis respectively
5	Tool pull out stage	Displacement along z-axis	Displacement along z-axis
6	Cooling stage	No movement	No movement

#### IV. RESULTS AND DISCUSSION

In order to examine the effects of the preheating in friction stir welding on temperature distributions in the workpiece experiment & numerical simulations were performed. Fig 6 (a) and (b) shows the temperature field of preheated and traditional FSW from the simulation.

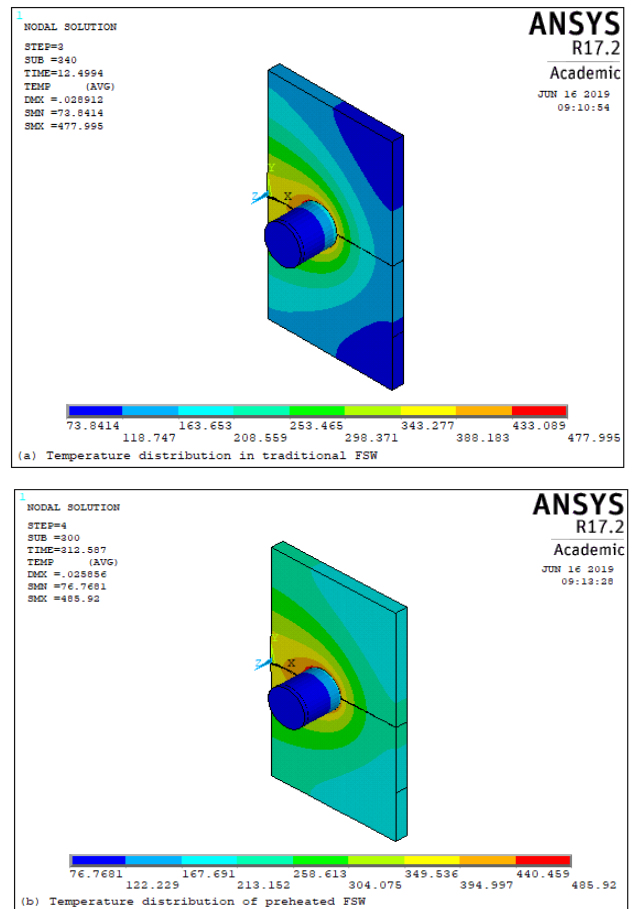

Fig. 6 Temperature field of workpiece in (a) Traditional FSW (b) Preheated FSW



## Experimental and numerical analysis of the effect of preheating in friction stir welding

In both cases, high temperature occurs at the tool and workpiece interface and peak temperature within the shoulder region is almost the same. It was observed that the peak temperature in preheated and traditional FSW was 486 °C and 478 °C respectively. From these results it can be demonstrated that the preheating is helpful to make soften the material before welding, resulting, tool needs less forces in plunging state. In addition, materials of stir zone can be properly mixed with FSW tool, without absorbing high heat.

These results reveal that the preheated FSW have little extent on total heat generation in stir zone and it has minor role on enhancement in peak temperature. It is due to friction coefficient between workpiece and tool. Friction coefficient and temperature mutually depends on each other. Friction coefficient between workpiece and tool decrease by increasing temperature. Consequently, heat generation from the friction is decreased. It is also observed temperature gradient is much steeper in front of the tool than the behind of the tool.

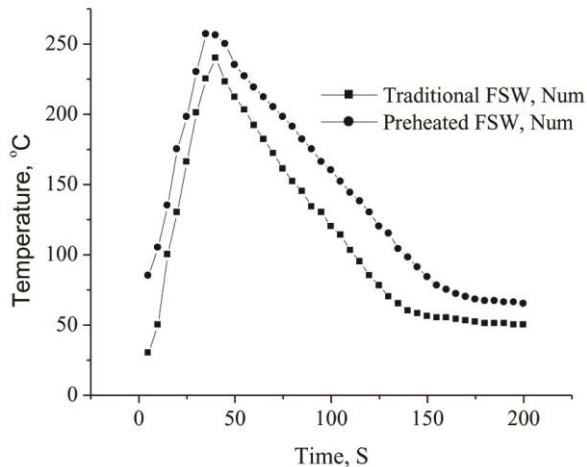

**Fig. 7 Comparison of temperature variation between traditional and preheated FSW at 12 mm from weld line in FEM**

Experimental observations of temperature distribution at 12 mm from weld line are shown in fig 8. The peak temperature of preheated FSW is 17 °C more than the traditional FSW. The overall error in peak temperature of numerical & experimental results was observed 5.84 % and 5.46 % in preheated and traditional friction stir welding respectively.

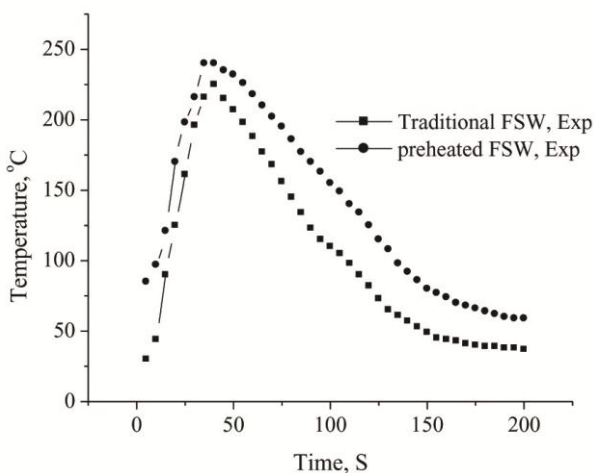

**Fig. 8 Comparison of temperature variation between traditional and preheated FSW at 12 mm from weld line in experimental results**

Fig 7 represents FEM results for temperature distribution in traditional and preheated FSW. It was found that the peak temperature in preheated FSW is 19°C more than that of traditional FSW.

From the obtained results it was also observed that the cooling rate of preheated FSW is decreases as compared to traditional FSW. It is due to heat transfer from workpiece to backing plate is reduced. It is well known that AA2099 T8 is a precipitates hardened material and slow cooling rate may helpful to re-precipitates of second phase.

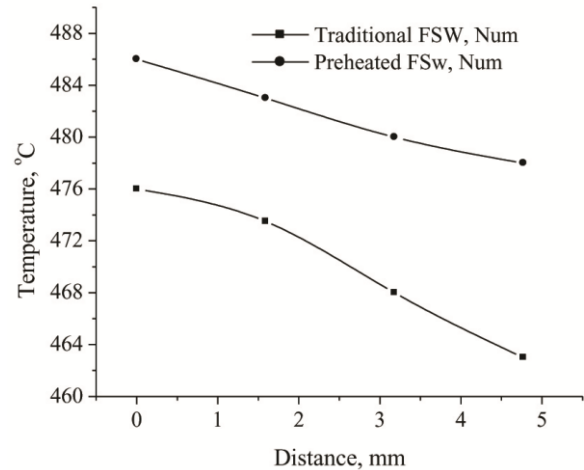

**Fig. 9 Temperature variations along the thickness of plate in FSW**

Fig 9 shows simulated result of preheated and traditional friction stir welding along the thickness of the plate. Four locations were chosen at 0, 1.66, 3.33, and 5 mm to predict temperature variation along thickness. In traditional friction stir welding crown side experiences more heat than that of bottom side. It is due to frictional and plastic deformational heat from shoulder and workpiece interface. In other side heat transfer rate is highest between backing plate and workpiece, resulting non uniform temperature distribution along thickness of welded sample

Chao et al. [21] observed temperature difference between top and bottom side was 60°C. To avoid this inhomogeneity in temperature distribution along thickness of welded plate preheating is applied from backing plate. It can be clearly observed from figure 8 that the difference in peak temperature of top and bottom surface in preheated friction stir welding is less than that of traditional friction stir welding. This demonstrates that the homogeneity of temperature along the thickness of the plate is increased in preheated friction stir welding.

## V. CONCLUSION

In order to the effects of preheating on the temperature distribution of friction stir welding of latest generation of AA 2099 T8, experiments & numerical simulations were performed. The following conclusions were obtained;

- Preheating increased 7.39% and 7.55% peak temperature as compared to traditional friction stir welding in FEA and experimental respectively.
- The overall error in peak temperature of numerical & experimental results is 5.84 % and 5.46 % in preheated and traditional friction stir welding respectively.
- Preheating increases homogeneity along the thickness of plate due to reducing temperature gradient along thickness.

## REFERENCES

1. Alam, Md Parwez, and A. N. Sinha. "Fabrication of third generation Al–Li alloy by friction stir welding: a review." *Sādhanā* 44, 6, 2019, 153.
2. Thomas, W. M., Nicholas, E. D., Needham, J. C., Murch, M. G., Templesmith, P., & Dawes, C. J. International patent application no (No. 9125978.8, p. 6). PCT/GB92/02203 and GB patent application, 1991
3. Sidhar, Harpreet, Rajiv S. Mishra, Anthony P. Reynolds, and John A. Baumann "Impact of thermal management on post weld heat treatment efficacy in friction stir welded 2050-T3 alloy," *Journal of Alloys and Compounds*, 722, 2017, pp. 330-338.
4. Tan, Y. B., X. M. Wang, M. Ma, J. X. Zhang, W. C. Liu, R. D. Fu, and S. Xiang, "A study on microstructure and mechanical properties of AA 3003 aluminum alloy joints by underwater friction stir welding," *Materials Characterization*, 127, 2017, pp. 41-52.
5. Imam, Murshid, Rintaro Ueji, and Hidetoshi Fujii, "Effect of online rapid cooling on microstructure and mechanical properties of friction stir welded medium carbon steel," *Journal of Materials Processing Technology*, 230, 2016, pp. 62-71.
6. Sun, Y. F., Y. Konishi, M. Kamai, and H. Fujii, "Microstructure and mechanical properties of S45C steel prepared by laser-assisted friction stir welding," *Materials & Design*, 47, 2013, pp. 842-849.
7. Santos, Telmo G., R. M. Miranda, and Pedro Vilaca, "Friction Stir Welding assisted by electrical Joule effect," *Journal of materials processing technology*, 214, 2014, pp. 2127-2133.
8. Liu, Xun, Shuhuai Lan, and Jun Ni, "Electrically assisted friction stir welding for joining Al 6061 to TRIP 780 steel," *Journal of Materials Processing Technology*, 219, 2015, pp. 112-123.
9. Bang, HanSur, HeeSeon Bang, GeunHong Jeon, IkHyun Oh, and ChanSeung Ro, "Gas tungsten arc welding assisted hybrid friction stir welding of dissimilar materials Al6061-T6 aluminum alloy and STS304 stainless steel," *Materials & Design*, 37, 2012, pp. 48-55.
10. Vijendra, Bandari, and Abhay Sharma, "Induction heated tool assisted friction-stir welding (i-FSW): a novel hybrid process for joining of thermoplastics," *Journal of Manufacturing Processes*, 20, 2015, pp. 234-244.
11. Santos, Telmo G., Rosa M. Miranda, and Pedro Vilaça. "Friction stir welding assisted by electrical joule effect to overcome lack of penetration in aluminium alloys," *In Key Engineering Materials*, 611, 2014, pp. 763-772.
12. Yaduwanshi, D. K., S. Bag, and Sukhomay Pal, "Numerical modeling and experimental investigation on plasma-assisted hybrid friction stir welding of dissimilar materials," *Materials & Design*, 92, 2016, pp. 166-183.
13. Long, X., and Sanjeer K. Khanna, "Modelling of electrically enhanced friction stir welding process using finite element method," *Science and Technology of Welding and Joining*, 10, 2005, pp. 482-487.
14. Shi, L., C. S. Wu, and Z. Sun, "An integrated model for analysing the effects of ultrasonic vibration on tool torque and thermal processes in friction stir welding," *Science and Technology of Welding and Joining*, vol. 23, 2018, pp. 365-379.
15. Hasan, Mohammed M., M. Ishak, and M. R. M. Rejab, "Effect of backing material and clamping system on the tensile strength of dissimilar AA7075-AA2024 friction stir welds," *The International Journal of Advanced Manufacturing Technology*, 91, 2017, pp. 3991-4007.
16. Imam, Murshid, Vikranth Racherla, and Kajal Biswas, "Effect of backing plate material in friction stir butt and lap welding of 6063-T4 aluminium alloy," *The International Journal of Advanced Manufacturing Technology*, vol. 77, no. 9-12, 2015, pp. 2181-2195.
17. Upadhyay, Piyush, and Anthony Reynolds, "Effect of backing plate thermal property on friction stir welding of 25-mm-thick AA6061," *Metallurgical and Materials Transactions A*, 45, 2014, pp. 2091-2100.

18. Zhang, Zhihan, Wenya Li, Junjun Shen, Y. J. Chao, Jinglong Li, and Yu-E. Ma, "Effect of backplate diffusivity on microstructure and mechanical properties of friction stir welded joints," *Materials & Design*, 50, 2013, pp. 551-557.
19. Yang, Xiawei, Wuyuan Feng, Wenya Li, Yaxin Xu, Qiang Chu, Tiejun Ma, and Weibing Wang, "Numerical modelling and experimental investigation of thermal and material flow in probeless friction stir spot welding process of Al 2198-T8," *Science and Technology of Welding and Joining*, 23, 2018, pp. 704-714.
20. Ansys Mechanical, A.P.D.L., 2017. Theory Reference, Ansys Inc.
21. Chao, Y.J., Qi, X. and Tang, W, "Heat transfer in friction stir welding—experimental and numerical studies," *Journal of manufacturing science and engineering*, 2003, 125(1), pp.138-145.

## AUTHORS PROFILE



**Md Parwez Alam.** He received B Tech degree in mechanical engineering department from Muzaffarpur Institute of Technology Muzaffarpur. He is a PhD pursuing student in mechanical engineering department in National Institute of Technology Patna. His research interests are Friction stir welding, FEA



**Amar Nath Sinha.** He is a Professor in mechanical engineering department, National Institute of Technology Patna. His research interests are Laser beam welding, Friction stir welding, finite element analysis.