

Protection Scheme using RPI Concept in STATCOM Compensated EHV System

Anuradha Kurekar, Piyush Khadke

Abstract: This research work present a protection scheme for fault detection and fault classification in EHV with static synchronous compensator (STATCOM) using Regulated Power index (RPI) concept. RPI per phase is defined as the ratio of the sum of sending end apparent power and receiving end apparent power to the apparent power at receiving end for that phase [1]. STATCOM is used for reactive power compensation and regulates the system voltage by absorbing and generating reactive power. As per the requirement of system parameter scheme is developed for the detection of fault, identification of faulty phase and tripping the faulty phase. This scheme will be validated by considering various fault test cases considering severe fault conditions with very low resistance, high fault resistance conditions and internal faults with static synchronous compensator (STATCOM) at sending end on the MATLAB model of transmission system at 220 KV level.

Index Terms: RPI concept, fault detection, transmission line, 48-pulse GTO thyristor model STATCOM.

I. INTRODUCTION

The transmission grid structure demands more power transfer capability and improved voltage level for loss cutback without risking stability of the system. Since the environmental impacts, it has become a tough task to construct new transmission lines therefore STATCOM is connected to EHV line to strengthen the system. But, presence of STATCOM in transmission system leads to a conventional impedance based distance relay to mal-operate many times, causing disruption in power and disturbance in grid stability. This occurs due to nonlinear a high capacitive current which is produced by series capacitors in abnormal conditions. To protect the transmission line from fault and re-closer of circuit there is need of protection for shunt compensation i.e. STATCOM.

II. RPI CONCEPT

This is a new concept called RPI based new per phase protection scheme for uncompensated system. RPI is defined as ratio of summation of apparent power of sending and receiving end to the receiving end apparent power. At a particular instance the power used in RPI is calculated as

multiplication of voltage and current phasors. Then in tripping decision the real part of RPI is used. Inspiration behind using the regulated power is that the power regulation profile in a system is constant. When there is slightly disruption or fault in the line, suddenly the power profile will change. Therefore, change in this power regulation can be used as a deciding for fault detection. So as to overcome reactive power loss variations due to line length, real part of RPI has been considered. This new concept of RPI based relaying scheme can be used as a main relay.

A. Formulation of RPI

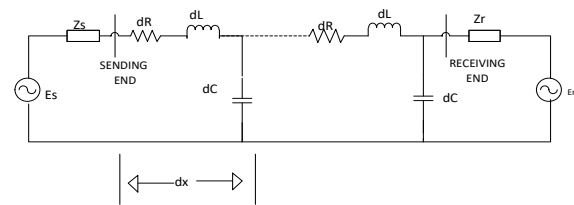

Fig.1. Equivalent network of two bus transmission line

Fig.1 shows the equivalent network of two bus transmission line network, where dL, dR and dC are distributed inductance, distribution resistance and distribution capacitance respectively for incremental line length dx. Zs are the source impedance of source Es and Zr are the source impedance of source Er. Sending end per phase apparent power and receiving end per phase apparent power are calculated from Fig.1. as

$$S_{si} = V_{si} \angle \theta_{si} \times I_{si}^* \angle \phi_{si}$$

(1)

$$S_{ri} = V_{ri} \angle \theta_{ri} \times I_{ri}^* \angle \phi_{ri}$$

(2)

Where, Ssi and Sri are the sending end and receiving end apparent powers for ith phase, correspondingly. RPI for ith phase is defined as the ratio of the sum of sending end apparent power and receiving end apparent power to the apparent power of receiving end for that phase.[1] RPI for ith phase is given by Equation (3) as

$$RPI_i = \left(\frac{S_{si} + S_{ri}}{S_{ri}} \right) \tag{3}$$

Put Equation (1) and (2) in Equation (3) we get,

Revised Manuscript Received on July 05, 2019.

Anuradha Kurekar, Mtech, 2nd year student, Shri Ramdeobaba College Of Engineering And Management, Nagpur, India.

Dr. Piyush Khadke, Assistant Professor, Shri Ramdeobaba College Of Engineering And Management, Nagpur, India.

Protection Scheme using RPI Concept in STATCOM Compensated EHV System

$$RPI_i = \left[1 + \left(\frac{V_{si} \angle \theta_{si}}{V_{ri} \angle \theta_{ri}} \right) \left(\frac{I_{si}^* \angle \phi_{si}}{I_{ri}^* \angle \phi_{ri}} \right) \right] \quad (4)$$

The power regulation profile in a given transmission system remains unaffected for given loading conditions. Ideally, if we consider sending end power and receiving end power to be equal then the RPI ratio will be 2. When there is any fault in the line, both power profiles of ends will change suddenly, during fault RPI ratio will change from 2, sending end and receiving end powers are not same. This change in RPI ratio will help to detect the fault in faulty phase. Variations in sending and receiving end voltages and currents are taken into contemplation in Equation (4). The angle in between the two equivalent sources of the sending and receiving ends of the system is less than 30° under normal working condition. In this research work, real part of RPI is calculated to decide the trip decision per phase. This real part of RPI is given as RRPI_i for *i*th phase.

$$RRPI_i = \text{Re} \left(\frac{S_{si} + S_{ri}}{S_{ri}} \right) \quad (5)$$

Therefore, change in RRPI is a measure of change in signature due to fault detected in the transmission system. So, change in RRPI per sample for *i*th phase is given by delRRPI_{ias},

$$\text{delRRPI}_i = |RRPI_i(k) - RRPI_i(k-1)| \quad (6)$$

Like this, the proposed new concept of RPI based relaying can be effortlessly useful in transmission system. In support with this theoretical analysis, the proposed RPI based fault detection and per phase trip protection has been authenticated with simulation results in results.

III. STATCOM

The STATCOM comprises of a step-down transformer with a leakage-reactance, a 3-phase GTO three level bridge and a DC capacitor. The AC voltage difference across the leakage reactance produces reactive power exchange between the STATCOM and the power system, such that the AC voltage at the power system can be regulated to increase the voltage profile of the power system, which is the most important responsibility of the STATCOM. If power system demands increase in reactive power, reactive power will flow from VSC to the power system and STATCOM supplies reactive power and acts as reactive power generator. If voltage of power system increases STATCOM absorb reactive power. DC Capacitor is used to supply constant DC voltage to the voltage source converter.

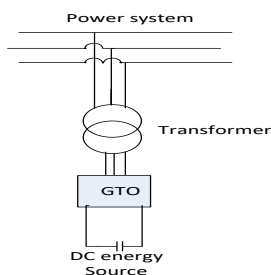

Fig.2. Simplified diagram of STATCOM

A. 48-pulse voltage source converter

It comprises of three-level inverters, four three-phase and four phase-shifting transformers. In the 48-pulse VSC, the dc bus is connected to the four 3-phase inverters. The four voltages generated by the inverters are applied to secondary windings of four zig-zag phase shifting transformers connected in Δ or Y. The four transformer primary windings are connected in series and the converter pulse patterns are phase shifted so that the four voltage fundamental components sum in phase on the primary side. [2] The 48-pulse converter can be used in high power applications without AC filters due to its high performance and low harmonic rate on the AC side. The output voltage have harmonics $n = 48r \pm 1$, where $r = 0, 1, 2, \dots$; i.e., 47th, 49th, 95th, 97th, ..., with magnitudes of 1/47th, 1/49th, 1/95th, 1/97th, ..., respectively, respect to the fundamental; on the DC side the lower circulating harmonic current will be the 48th. [2]

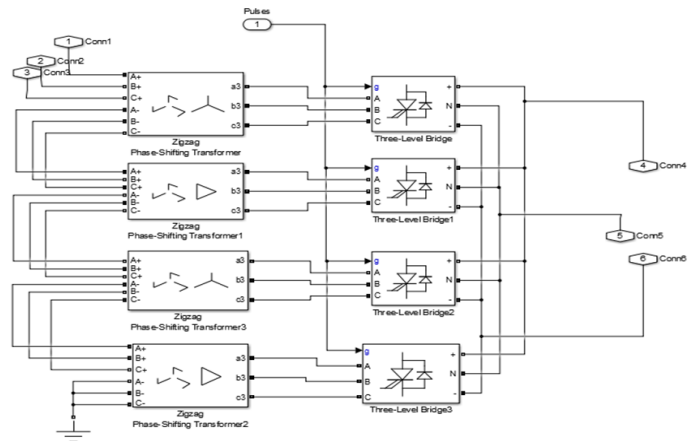

Fig.3. MATLAB model of 48-pulse VSC and zig-zag transformer

IV. SIMULATION RESULTS

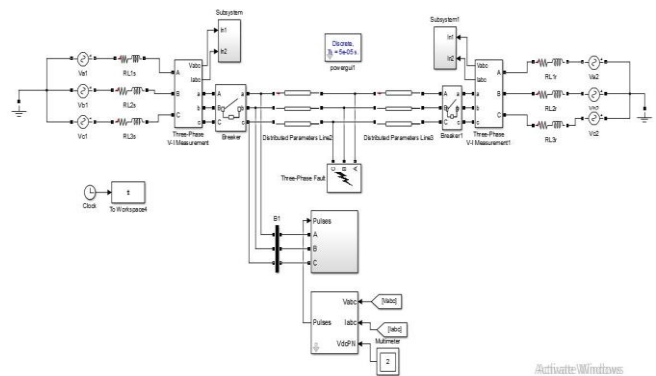

Fig.4. Simulation model of Transmission Line of 220KV

Ideally sending end apparent power is equal to receiving end apparent power, so let us assume S_{si} and S_{ri} each as 1 pu, from equation(3) the RPI ratio will be 2.

Let us consider a sudden change of 0.5 pu in loading, then the Ssi and Sri will be 1.5 pu each. So, the new RPI ratio will also be 2. But, if there is any occurrence of fault, Ssi and Sri powers will not same depending upon fault location and other parameters, due to this RPI ratio and it is not equal to 2. RPI ratio will have deflection from the normal value. This change in the RPI ratio is used to detect the fault per phase, which is represented as delRRPI. Likewise, rate of change of fault current is low in high Rf faults. In order to make RPI scheme extremely sensitive even in case of high resistance faults, the threshold value was set to a low value 0.5×10^{-4} . To make the scheme more reliable; trip decision was set to be issued only when 5 samples crossed the threshold value.

For the validation of RPI scheme following Parameters are designed.

Variation	Conditions
STATCOM position	Sending end
Type of fault	ag,bg,cg,ab,bc,ac,abg,bcg,acg and abc(3-ph)
Fault location	5 km to 295 km
Fault resistance(Rf)	0.01Ω - 400Ω
Fault inception	0.1s to 1s

A. Case I

Fig.5 gives an outline of test result, in this a-g fault at 138 km distance from sending end with Rf = 10 Ω. Fault was created with fault inception between 0.3 sec to 0.4 sec. As per the criterion, if value of delRRPI is more than 0.5×10^{-4} threshold in 5 samples, then fault is detected and trip signal is passed for that respective phase. As per this criterion, fault was detected at 0.308 sec in a-phase as shown in Fig.5. Whereas, there was no fault detection in b-phase and in c-phase as RRPI value did not cross the set-threshold value.

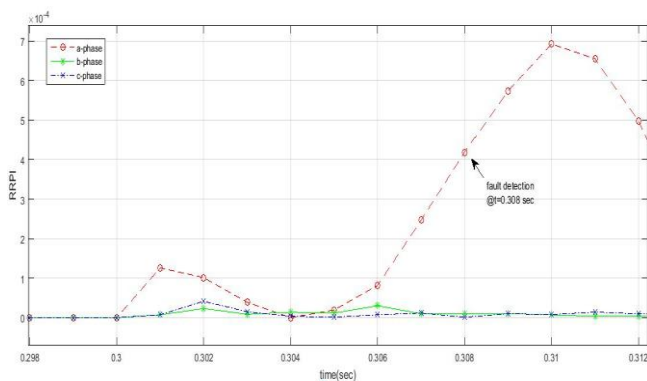

Fig.5. Simulation plots of per phase delRRPI for a-g fault

B. Case II

Fig.6 gives an outline of test result, in this a-c fault at 98 km distance from sending end with Rf = 1 Ω. Fault was created with fault inception between 0.2 sec to 0.35 sec. As per the criterion, if value of delRRPI is more than 0.5×10^{-4} threshold in 5 samples, then fault is detected and trip signal is passed for that respective phase. As per this criterion, fault was detected at 0.21 sec in a-phase and at 0.209 sec in c-phase as shown in Fig.6. Whereas, there was no fault detection in b-phase as RRPI value did not cross the set-threshold value.

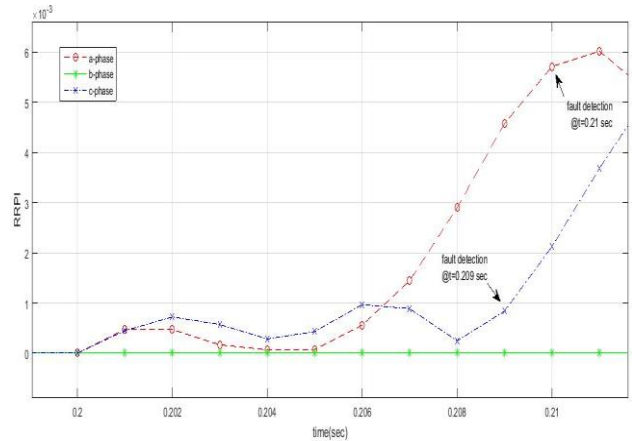

Fig.6. Simulation plots of per phase delRRPI for a-c fault

C. Case III

Fig.7 gives an outline of test result, in this b-c-g fault at 188 km distance from sending end with Rf = 100 Ω. Fault was created with fault inception between 0.4 sec to 0.5 sec. As per the criterion, if value of delRRPI is more than 0.5×10^{-4} threshold in 5 samples, then fault is detected and trip signal is passed for that respective phase. As per this criterion, fault was detected at 0.408 sec in b-phase and at 0.406 sec in c-phase as shown in Fig.7. Whereas, there was no fault detection in a-phase as RRPI value did not cross the set-threshold value.

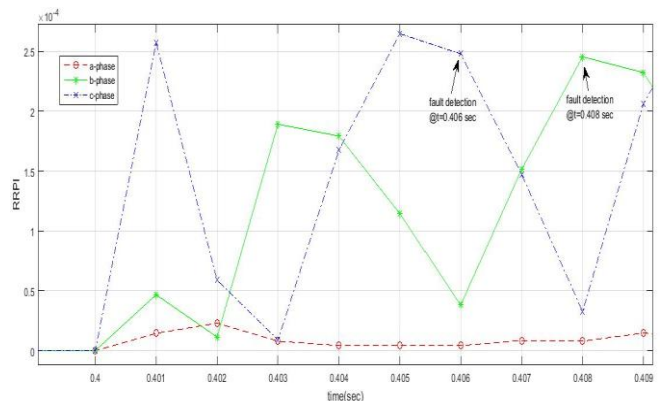

Fig.7. Simulation plots of per phase delRRPI for b-c-g fault

D. Case IV

Fig.8 gives an outline of test result, in this a-b-c fault at 258 km distance from sending end with Rf = 150 Ω. Fault was created with fault inception between 0.35 sec to 0.4 sec. As per the criterion, if value of delRRPI is more than 0.5×10^{-4} threshold in 5 samples, then fault is detected and trip signal is passed for that respective phase. As per this criterion, fault was detected at 0.355 sec in a-phase, b-phase and in c-phase respectively as shown in Fig.8.



Protection Scheme using RPI Concept in STATCOM Compensated EHV System

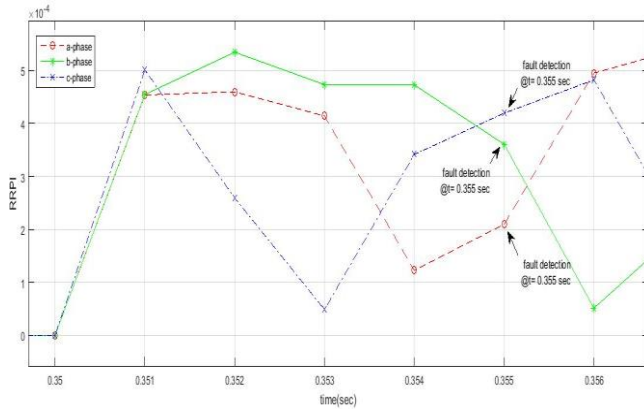

Fig.8. Simulation plots of per phase delRRPI for a-b-c fault

V. CONCLUSION

The RPI scheme has been proposed for fault detection, faulty phase identification and tripping of EHV transmission line with STATCOM in this research paper. Many range of fault Condition has been applied to testing data in order to improve the regularity of the scheme. Simulation results show that this scheme works accurately in various ranges of fault conditions and within half cycle of time, fault is detected. There is no necessity to change the proposed relay threshold settings even with different high fault resistances which have to be changed in conventional relay settings. The proposed online scheme, with minimum difficulty and fast fault detection, is a possible protection solution to STATCOM compensated EHV transmission system.

REFERENCES

1. P. Khadke, N. Patne and G. Shinde, "Digital relaying scheme for EHV transmission system incorporating regulated power index (RPI) concept using synchronized measurement," *Journal of Engg. Research* Vol. 5 No. (2) June 2017 pp. 141-15.
2. M. S. El-Moursi and A. M. Sharaf, "Novel Controllers for the 48-Pulse VSC STATCOM and SSSC for Voltage Regulation and Reactive Power Compensation," *IEEE Trans. On Power Systems*, VOL. 20, NO. 4, November 2005.
3. R. Mohan and R. K. Varma, "Thyristor-Based FACTS Controllers for Electrical Transmission Systems," *IEEE Press*, 2002.
4. Y. Liang and C. O. Nwankpa, "A new type of STATCOM based on cascading voltage-source inverter with phase-shifted unipolar SPWM," *IEEE Trans. Ind. Appl.*, vol. 35, no. 5, Sep./Oct. 1999, pp. 1118-1123.
5. Q. Yu, P. Li, and Wenhua, "Overview of STATCOM technologies," *IEEE Int. Conf. Electric Utility Deregulation, Restructuring, Power Technologies*, Apr. 2004, pp. 647-652.
6. P.W.Lehn, "Exact modeling of the Voltage Source Converter", *IEEE Trans. on Power Delivery*, Vol. 17, No.1, January 2002, pp.217-222

AUTHORS PROFILE



Anuradha Kurekar (28 year) is currently studying Mtech in Power Electronic and Power System, Shri Ramdeobaba College of Engineering and Management, Nagpur. She has completed B.E (20104) in Electronics & Power from Rajiv Gandhi College of Engineering, Research and Technology, Chandrapur.



Dr. Piyush Khadke (31years) is currently working as assistant professor in Electrical Engineering department, Shri Ramdeobaba College of Engineering and Management, Nagpur. He has been awarded PhD degree from VNIT, Nagpur in 2017 in the area of Transmission Line protection field. He has also worked in Power Grid

Corporation of India Ltd. for 2 years. He has completed B.Tech (2010) in Electrical & Electronics and M.Tech (2014) in Integrated Power System from VNIT, Nagpur. His area of research work is EHV Transmission Protection system, Digital relaying, EHV Substation equipment's, and Power system.

