

# Low Cost Remote Monitoring of Solar Plant through RS485 Communication

Merugu Siva Rama Krishna, K. Dinesh, Niteesh S Shanbog

**Abstract:** Solar energy has already grown to be the go-to form of renewable energy in the modern power grid. Monitoring the generation and consumption is imperative in order to properly plan the operation as well as the installation of additional capacity. Low-cost remote monitoring of a standalone solar farm through a Raspberry Pi is proposed in this paper. RS485 is used for data transfer between the inverter and the Raspberry Pi. Remote data monitoring is then achieved by pushing the data into the cloud from the Raspberry Pi. Real-time information is made accessible which will help in preventive maintenance, fault detection and also generate a database to aid in forecasting. This IoT based solution is suitable for solar installations in remote and inaccessible areas where regular access is inconvenient. The total number of units of power generated in a day can be calculated from which an estimate can be made about the number of units generated. From this, the financial savings that can be made by implementing a photovoltaic system for energy generation.

**Index Terms:** Solar Energy, Raspberry Pi, RS485, Modbus Protocol.

## I. INTRODUCTION

Solar Energy is set to be one of the largest sources of power in the coming years. The global installed capacity of solar has exceeded 500GW and poised to grow more. PV prices are expected to drop even as manufacturing is set to double [1]. The rapid growth of distributed energy, of which solar is a major form will bring in radical changes in the power grid. Especially in poor countries, the adoption of solar could bring in clean and cheap power to millions of rural households with no geopolitical implications. Solar energy, especially in equatorial territories are abundant and easy to harvest. Advancements in material science and nanotechnology have led to the developments of newer types of photovoltaic panels which can capture and convert solar energy far more efficiently and in a cost-effective way [2]. In an increasingly power-hungry world, solar energy is one of the most easily exploitable resources which can fill in the void left by fossil fuels and can even power the planet [3].

Microgrids have been used to electrify remote places. Distributed Energy Resources like play a major role in such microgrids [4]. Despite all these advantages, solar is highly unreliable and susceptible to variation in irradiance, temperature as well as atmospheric conditions. Maintenance of panels

also impacts the efficiency of solar energy harvesting in a big way. Soft shading of the PV due to soiling impacts the voltage. The effect of this depends on whether the panel is partially shaded or not. Hard shading of the PV panel, which may occur due to the presence of pollutants do not affect the voltage but reduces the current [5]. The power generated as a result is thus adversely affected. In remote installations where regular access can be a hindrance, this can affect the maintenance of the PV panels and therefore reduce the Return on Investment (RoI). There is a growing need to remotely monitor renewable generating sources on the go. Remote monitoring is achievable due to advancements in IoT and communication technologies. Internet of Things (IoT) is a system of interconnected things using various communication tools and technologies enabling data transfer at every level of the system [6]. The objective of IoT is to automate all processes using predefined logic so as to eliminate human intervention. IoT has grown to include every field conceivable to the human imagination like agriculture, manufacturing, mobility, energy, education, and many more [7]. The development of low-cost computing devices like Raspberry Pi has enabled the deployment of IoT at every conceivable application. Several IoT based solutions have been developed for monitoring of PV cells. Remote monitoring is achieved by data transfer from the inverter to a processor which can then push the data to the cloud. RS485 is a standard used for multi-port communication [8]. The Modbus protocol is a protocol between the master and slave which is used by the master to change the configuration of the slaves or to read measures [9].

The Raspberry Pi is a low-cost computing device which is having increasing importance in IOT driven applications. Its small size and low cost make it the go-to computer device for such applications. Another added advantage of using the Raspberry Pi is that it can be used along with Node-Red. Node-Red is a data flow platform based on javascript but programmed on visual representative blocks [10]. The Node-Red platform is used with Raspberry Pi to create several IoT devices for monitoring and data collection from sensors as in [11], [12] and [13].

In this paper, IoT based remote monitoring of a PV plant is achieved using a Raspberry Pi. The data transfer from the solar inverters to the Raspberry Pi is done using RS485 and this data is then pushed to the cloud using the Node-Red platform. The methodology adopted to achieve this is shown in Section II.

**Revised Manuscript Received on July 10, 2019.**

**Merugu Siva Rama Krishna**, Electrical Engineering Department, IIIT RK Valley, RGUKT –AP, YSR Kadapa, Andhra Pradesh, India.

**K.Dinesh**, Electronics and Communication Department, IIIT RK Valley, RGUKT –AP, YSR Kadapa, Andhra Pradesh, India.

**Niteesh S Shanbog**, Electrical and Electronics Department, PES University, Bengaluru, Karnataka, India.



## Low Cost Remote Monitoring of Solar Plant through RS485 Communication

This section is followed by the different hardware installation methods used. The results obtained are shown in Section IV. Section V analyses the results and discusses the possible scope for improvement in this method of data collection and analysis

### II. METHODOLOGY

The primary objective of this paper is to remotely access the solar inverter data obtained from the PV plant. The general block diagram of the PV plant is shown in Fig.1. The photovoltaic panels are connected in arrays to form a solar farm. Since the PV panels generate power in DC, it becomes imperative to convert this power to AC so that it can be used for domestic applications. An inverter is used for this purpose. Since the inverter is the important link between the photovoltaic panels and the grid, this becomes an easy place to collect the data.

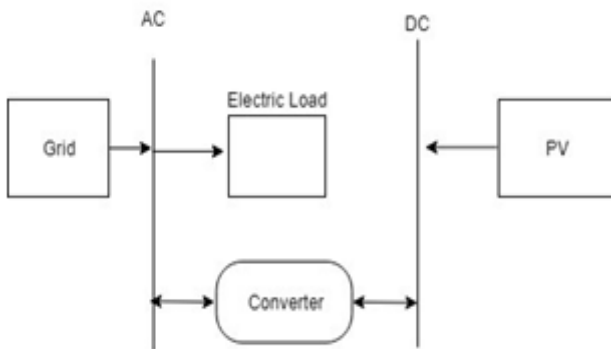

Fig.1. A generic grid connected solar farm

To achieve this, the current and voltage readings from the inverter are transferred to the Raspberry Pi using RS485. Modbus Protocol is used to control the flow and schedule of the data transfer. The Raspberry Pi is then used to push this data to the cloud. This has been configured using Node-Red. The general architecture adopted to achieve this is shown in Fig.2.

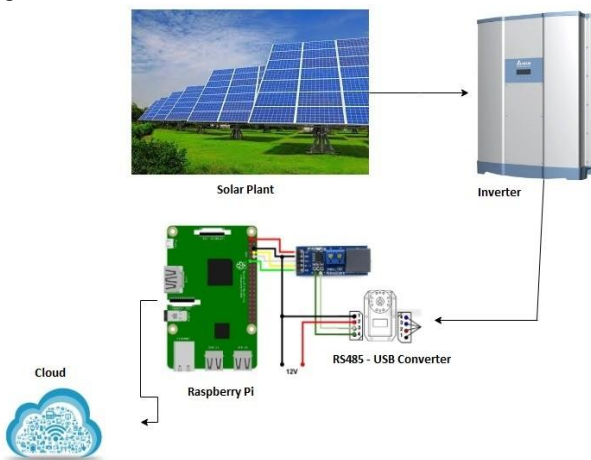

Fig.2. General architecture of the data collection method

Raspberry Pi has been chosen as the processor to receive the data from the inverter and process it. This data transfer is

achieved through RS485. RS485 allows for the connection of multiple numbers of devices in the network. A single pair of wires can be used to connect hundreds of devices. Modbus Protocol is used for RS485 communication to set the master and slave devices. The Raspberry Pi is set as the master device and the inverter as the slave. The Modbus protocol helps to schedule the data transfer. Modbus protocol is widely used in Industrial Automation systems due to its ease of use. The data transfer is in 16-bit Cyclic-Redundant Checksum. This allows for reliable transfer of data in all forms like tables, ASCII text, floating point and queues. The master-slave operation can be represented in Fig3. From the figure, it is apparent that the master (client) initiates a service request. The server (slave) which is the Inverter, in this case, performs the action and initiates a response. The master which is the Raspberry Pi then receives the data. This data can then be processed and published on the cloud. The communication card of the inverter contains the RS485 port. The data frame of the communication card consists of the following parts:

- Slave address: It is an 8-bit data which consists of the address of the various slave devices connected to the serial line. It has to be ensured that the slave address matches with the inverter address.
- Function code: The function code is an 8-bit data. There are 4 types of functions which can be used to set the holding registers, read the data, set single byte registers or multi-byte registers.
- Data: It consists of  $N \times 8$  bits. It includes the start register address, the data length the number of data bytes and the data content. The data is arranged in Big Endian form.
- CRC Check: CRC is a 16-bit data which is used to detect an error in the raw data. It is used to prevent random errors in transmission.

This data is then processed in the Raspberry Pi and the relevant voltage and current information are extracted.

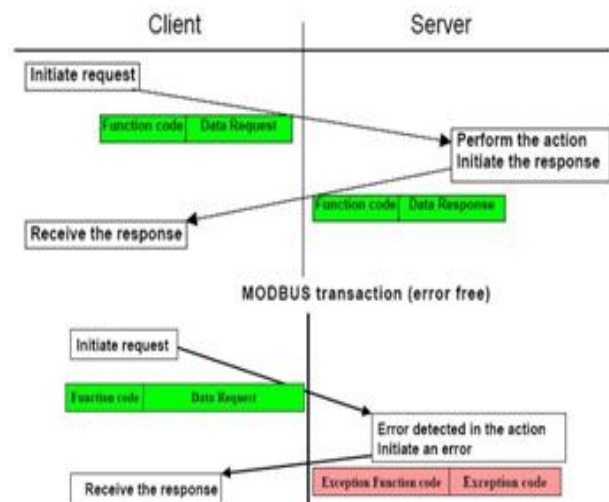

Fig.3. Modbus Protocol between Master and Slave

The hardware devices are wired together and the data push to the cloud is achieved through Node-Red. It is a browser-based java script editor that can be used to graphically program the data flow. The processed data can be viewed on a computer or a mobile phone as long as the user is connected to the local IP address. The entire flowchart of operation is shown in Fig.4.

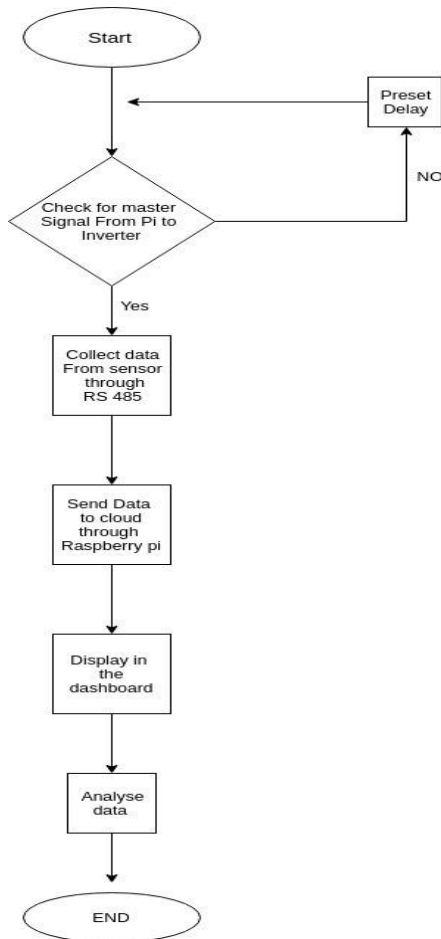

Fig.4. Flowchart of Data Flow\

The installation of the setup in order to move the data generated from the inverter to the Raspberry Pi and then to the cloud is explained in the following section

### III. INSTALLATION

An inverter is used to convert the DC power produced by the photovoltaic panels to AC. An RS486 communication port will be present in the inverter. The RS485 to serial converter is used to convert the data from the RS485 port to the USB port which is present in the Raspberry Pi.

TABLE I  
INVERTER SPECIFICATIONS

Parameters	Values
Power	18kW
Input DC Voltage	200 - 1000 V
Output AC Voltage	230 V
Maximum Input Current	44 A
Frequency	50Hz
Total Harmonic Distortion	≤ 0.3

The termination resistor has to be in the ON position to enable data transfer. The termination resistor is used to match the impedance of the cabling to that of the transmission network. This enables the receiver to receive maximum signal power. The specification of the photovoltaic system is shown in TABLE I.

Inorder to use the Modbus protocol to program the master and the slave, the Q Modbus Simulator software is used. This software consists of a graphical interface which makes it easy to control the Modbus slaves through the slave. This simulator includes a bus monitor through which we can check all the traffic in the serial line. The results obtained using this setup is shown in the next section.

### IV. RESULTS

Using this setup, the data can be remotely acquired. Fig.5 shows the typical solar irradiation of the location along with the clearness index. The solar irradiation is the power per unit area that is incident on the surface of the earth. Having a higher solar irradiance can help in optimal power generation. The clearness index is a measure of the clearness of the sky.

Fig.5. Solar irradiance and Clearness Index

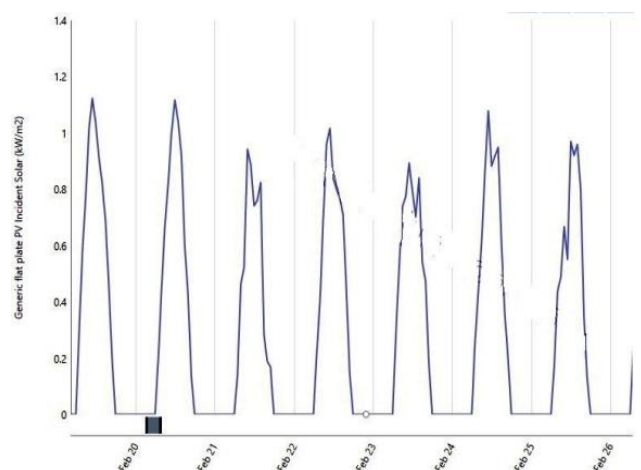
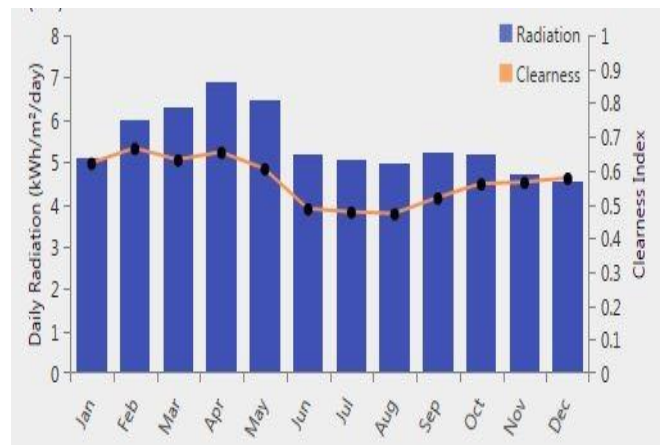

Fig.6. Power generated from the solar farm

Fig.6 shows the power generated by the photovoltaic panels. For an 18kW solar power plant, the yearly savings were calculated. The average generation was 65 units a day 23400 units a year. For a nominal saving of 12% a year, an average of 22500 rupees can be saved. This saving is arrived by using a nominal price of Rs 8 per kWh.

## V. CONCLUSION

The development of renewable energy sources like solar has helped in alleviating the stress on the energy grid. These photovoltaic panels can be installed in remote places. Advancement in IoT has enabled greater access to the data that can be generated in various places. Monitoring of the data from remote installations of photovoltaic panels is one such possibility that has been successfully explored in this paper.

The full capability of the Raspberry Pi based monitoring system has been demonstrated in this paper. RS485 has been used for data communication between the devices and Modbus protocol was used for the scheduling of data transfer and to establish a hierarchy of devices. The current and voltage data were obtained remotely and graphically demonstrated on a computer device. Node-Red is used to graphically program the data flow. The power generated by the photovoltaic panels was calculated. The cost savings which can be made by opting for a renewable-based energy system can then be estimated. This method gives a low cost and comparably simple method of acquiring data from a solar inverter.

## VI. FUTURE SCOPE

This method of data acquisition using an RS485 communication card can be extended to various industrial applications. Different types of sensor data like vibration, gas concentration, temperature, humidity, pressure etc can be transferred. Thus, remote monitoring of industrial equipment can be achieved. The flexibility of this method is one of the biggest advantages. Addition of additional sensors can yield additional information about the system. Additional system information can bring enable a more minute analysis of the system.

Another interesting area of research will be to utilize the data obtained and draw meaningful conclusions about the viability of the project as well as to schedule the maintenance. Developing applications which can give priority based alerts about real-time generation as well as suggest preemptive actions should be made possible.

Machine learning algorithms can be used to forecast the future solar irradiance to help for planning of new solar farms. Localized weather prediction models can be developed and trained with the available data from this monitoring system.

## REFERENCES

1. K. Aanesen, S. Heck, and D. Pinner, "Solar power: Darkest before dawn," 2017.
2. N. S. Lewis, "Toward cost-effective solar energy use," *science*, vol. 315, no. 5813, pp. 798–801, 2007.

3. N. S. Lewis and D. G. Nocera, "Powering the planet: Chemical challenges in solar energy utilization," *Proceedings of the National Academy of Sciences*, vol. 103, no. 43, pp. 15729–15735, 2006.
4. T. Ackermann, G. Andersson, and L. Söder, "Distributed generation: a definition," *Electric power systems research*, vol. 57, no. 3, pp. 195–204, 2001
5. M. R. Maghami, H. Hizam, C. Gomes, M. A. Radzi, M. I. Rezadad, and S. Hajighorbani, "Power loss due to soiling on solar panel: A review," *Renewable and Sustainable Energy Reviews*, vol. 59, pp. 1307–1316, 2016.
6. J. Gubbi, R. Buyya, S. Marusic, and M. Palaniswami, "Internet of things (iot): A vision, architectural elements, and future directions," *Future generation computer systems*, vol. 29, no. 7, pp. 1645–1660, 2013.
7. C. Srinivasan, B. Rajesh, P. Saikalyan, K. Premsagar, and E. S. Yadav, "A review on the different types of internet of things (iot)," *Journal of Advanced Research in Dynamical and Control Systems*, vol. 11, no. 1, pp. 154–158, 2019.
8. L. Geng, P. Wang, C. Ma, and H. Jia, "Design and implement of rs485 high speed data communications protocol [j]," *Journal of Tsinghua University (Science and Technology)*, vol. 8, 2008.
9. Z. Xiaoxiang, "Modbus protocol and programing [j]," *Electronic Engineer*, vol. 7, p. 016, 2005.
10. S. Kumar and A. Jasuja, "Air quality monitoring system based on iot using raspberry pi," in *2017 International Conference on Computing, Communication and Automation (ICCCA)*, pp. 1341–1346, IEEE, 2017.
11. A. Kaur and A. Jasuja, "Health monitoring based on iot using raspberry pi," in *2017 International Conference on Computing, Communication and Automation (ICCCA)*, pp. 1335–1340, IEEE, 2017.
12. M. Blackstock and R. Lea, "Fred: a hosted data flow platform for the iot built using node-red," *Proceedings of MoTA*, 2016.
13. N. A. Othman, M. R. Zainodin, N. Anuar, and N. S. Damanhuri, "Remote monitoring system development via raspberry-pi for small scale standalone pv plant," in *2017 7th IEEE International Conference on Control System, Computing and Engineering (ICCSCE)*, pp. 360–365, IEEE, 2017.

## AUTHORS PROFILE



Merugu Siva Rama Krishna received the B.Tech. degree in Electrical and Electronics Engineering from the Koneru Lakshmaiah College of Engineering, Guntur, India, in 2010, and the M.Tech. degree in Electrical Drives and Power Electronics from IIT Roorkee, India, in 2012. He was a Research Associate with the Rolls Royce@NTU Corporate Lab, Nanyang Technological University, Singapore, from 2015 to 2016. He is currently an Assistant Professor with the Department of Electrical Engineering, IIIT-RK Valley, Rajiv Gandhi University of Knowledge Technologies-AP, India. His current research interests include the prognosis and diagnosis of electrical machines, IOT applications in power systems, Power electronics and electrical drives



K Dinesh graduated with a B.Tech in Electronics and Communications Engineering from IIIT-RK Valley, RGUKT-A.P, India in 2019. He specializes in Embedded Systems, Drone Designing and Machine Learning. His prime interests are in developing IoT based devices for various industrial applications.



Nitesh S Shanbog graduated with a B.E from BMS Institute of Technology, India in 2017 and an M.Tech in Electrical and Electronics Engineering from PES University, India in 2019. His specialization is in Power Electronic Drives and Energy Systems. His areas of interests involve the use of IoT in Power Systems for data monitoring and analysis.

