

# LPG Gas Measurement & Detection using GPS

Somashekhar Malipatil, B. Shilpa, R. Jayasudha

**Abstract:** The objective of this work is to monitor the gas cylinder continuously and display the weight of gas present inside the cylinder and send an alert to the user when the gas weight comes below the threshold level of 2kgs it sends a message to the user and it also detects any leakage occurring and if any leakage occurs it displays the level of leakage occurring and sends an SMS to the user and alerts.

**Index Terms:** Arduino, LPG, GPS, MQ6 sensor, Load cell, Signal amplifier.

## I. INTRODUCTION

GSM based LPG weight and LPG leakage detection System has application in Home, Hotels, restaurants & Industries. This work is used to monitor the weight of LPG gas cylinder. Whenever LPG Gas cylinder is empty, we give request for new cylinder at the office of Gas cylinder provider. several times it happens that because of the Rush or due to the shortage of cylinder, there is a delay in providing the gas cylinder. Main reason is, we inform the gas provider at the last moment when the gas is empty. To avoid all such situations, we have implemented a project called SMS based LPG gas weight detection using GSM technology. In this project we have used a load cell as weight sensor. This sensor will be placed below the LPG gas cylinder. Output of weight sensor is given to microcontroller. Microcontroller will continuously monitor the weight of LPG gas. When this LPG gas becomes 20% of weight, this system sends low warning message to the owner and owner will get SMS. The SMS will be "Weight of LPG gas is below 20%".

## II. PROPOSED WORK

This work proposes an advance and innovative approach for LPG leakage detection, prevention and automatically sends the alert to the user for refill. In advance, the system provides the automatically monitors LPG regulator also if leakage is detected the system will automatically sends the SMS alert to the user. Hence it helps to avoid the explosion and blast. The proposed work consists of a Arduino, Power supply, LCD Display, GSM modem, MQ6 sensor, Load cell and Signal amplifier as shown in fig1.

**Arduino:** In this project Arduino plays important role in interfacing the components to it. Input is given to the Arduino and output is taken from Arduino by using digital pins for displaying the output.

Revised Manuscript Received on July 06, 2019.

**Somashekhar Malipatil**, Assistant Professor, Dept. of ECE, AVNIET, Hyderabad, India.

**B. Shilpa**, Assistant Professor, Dept. of ECE, AVNIET, Hyderabad, India.

**R. Jayasudha**, Assistant Professor, Dept. of ECE, AVNIET, Hyderabad, India.

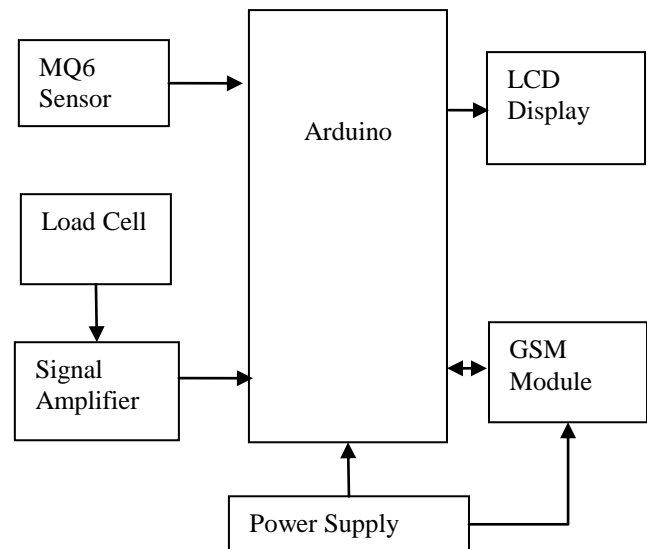

Fig.1 Block diagram of LPG weight and leakage detection using GSM

**Power Supply:** A power supply circuit provides power to all the components to activate it consists of a transformer, bridge rectifier, capacitor (acts as filter) and two regulators 7812 and 7805. The DC supply obtained from the capacitor is regulated to 12 volts by using 7812, which is used by GSM module and this 12 volts is again regulated to 5 volts using 7805. 5 volts is supplied to our Arduino and other devices.

**GSM Modem:** Here we are using GSM MODEM to communicate with the mobile phone to which we are going to send the message. If leakage is detected and weight of the object/cylinder is below particular threshold level then it sends the SMS to the user.

**LCD:** LCD is used to display the information about the current process. We are using 16\*2 LCD i.e., Liquid Crystal Display. It has two rows and can display 16 characters in each row.

**MQ6 Sensor:** This sensor will detect the gases (Iso propane, Butane) at a concentration of 300-10000ppm. When a gas is detected by the sensor then it compares with the comparator present in the sensor for producing digital logic data output to the Arduino.

**Loadcell:** When pressure is applied on load cell. Then strain gauge generates electrical signal on deformation as its effective resistance changes on deformation and wheat stone bridge becomes unbalanced. Then produces output electrical signal in few milli volts.

**Signal Amplifier:** The output of the load cell is weak signal is given to signal amplifier to increase the signal strength and it converts analog to digital data by using ADC. The output of the signal amplifier is given to Arduino.

## LPG Gas Measurement & Detection using GPS

Load cell and MQ6 sensor are the two inputs which are interfaced with Arduino. The output of the Arduino will be based on applied inputs. In these we use MQ6 sensor to detect some of the combustible gases like iso propane and butane, therefore those gases will be detected by MQ6 sensor, In which due to leakage detection we have to protect ourself we use alert system as GSM and also for status purpose we use display called LCD display. Similarly one more application like LOADCELL such that when it is below threshold level than reference level then that user will get SMS through GSM and status will show on display.

### III. CIRCUIT CONNECTIONS

Firstly the required operating voltage for the Arduino is 5V. Hence the 5V D.C. power supply is needed by the same. The regulated 5V is generated by first stepping down the 230V to 12V by the step down transformer and then regulated to 5V by 7805 and is connected to the microcontroller. The LCD display 4 data lines (d4,d5,d6,d7) are connected to Arduino digital pins 2,3,4,5, and the status of the process and results are displayed on the LCD display.

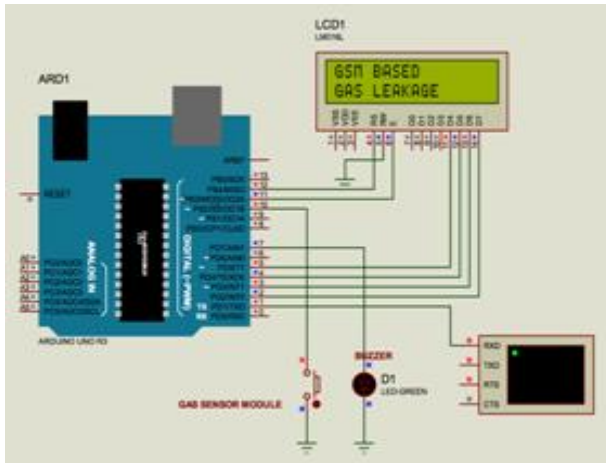

Fig.2 Proteus Schematic Diagram

The GSM module RX pin is connected to Arduino TX pin (d1) for receiving of the messages to the mobile from the module. The load cell four wires are interfaced to signal amplifier. From the signal amplifier DT, SCK Pins are connected to the Arduino analog pins A0 and A1. A0 is a clock, A1 is a data.

### IV. CIRCUIT OPERATIONS

The power supply 5V is given to the Arduino through an adapter. When MQ6 sensor detects the gases and compare with the comparator and which gives digital logic data to Arduino. If the logic is '0' then the gas leakage is detected similarly when the logic is '1' then the gas leakage is not detected therefore the Arduino takes proper action, and SMS alert is sent to user phone in case of gas leakage occurs. The output of the MQ6 sensor is given Arduino to the digital pin (D10) and the output of the Arduino is given to input as LCD to display the status of the leakage. Whenever a force/pressure is applied on the load cell it will convert force in to electrical signal, the output of the load cell is few milli volts. To increase the strength of the signal we are using HX711 signal amplifier. In HX711 it consisting of ADC which is used to convert from analog to digital data given to Arduino for

weight measurement. Whenever cylinder weight goes below some threshold value. The SMS alert is given to the user for the registration of new cylinder and displays the weight of the cylinder in LCD.

### V. ARDUINO HARDWARES

#### Arduino:

In this project Arduino plays important role in interfacing the components to it. Input is given to the Arduino and output is taken from Arduino by using digital pins for displaying the output.



Fig.3 Arduino Board

#### Power Supply:

A power supply circuit provides power to all the components to activate it consists of a transformer, bridge rectifier, capacitor (acts as filter) and two regulators 7812 and 7805. The DC supply obtained from the capacitor is regulated to 12 volts by using 7812, which is used by GSM module and this 12 volts is again regulated to 5 volts using 7805. 5 volts is supplied to our Arduino and other devices.

#### Modem:

Here we are using GSM MODEM to communicate with the mobile phone to which we are going to send the message. If leakage is detected and weight of the object/cylinder is below particular threshold level then it sends to the SMS to the user.



Fig.4 GSM Modem

#### LCD:

LCD is used to display the information about the current process. We are using 16\*2 LCD i.e., Liquid Crystal Display. It has two rows and can display 16 characters in each row.

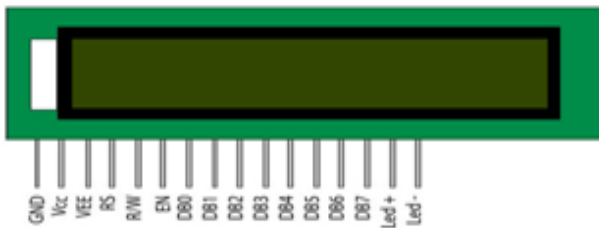

Fig.5 LCD

**MQ6 Sensor:**

This sensor will detect the gases (Iso propane, Butane) at a concentration of 300-10000ppm. When a gas is detected by the sensor then it compares with the comparator present in the sensor for producing digital logic data output to the Arduino.



Fig.6 MQ6 Sensor

**LOADCELL:**

When pressure is applied on load cell. Then strain gauge generates electrical signal on deformation as its effective resistance changes on deformation and wheat stone bridge becomes unbalanced. Then produces output electrical signal in few milli volts.

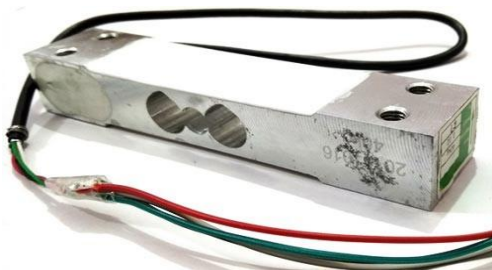

Fig.7 Load Cell

**SIGNAL AMPLIFIER:**

The output of the load cell is weak signal is given to signal amplifier to increase the signal strength and it converts analog to digital data by using ADC. The output of the signal amplifier is given to Arduino.

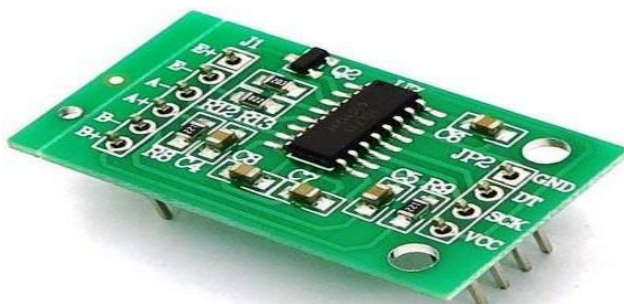
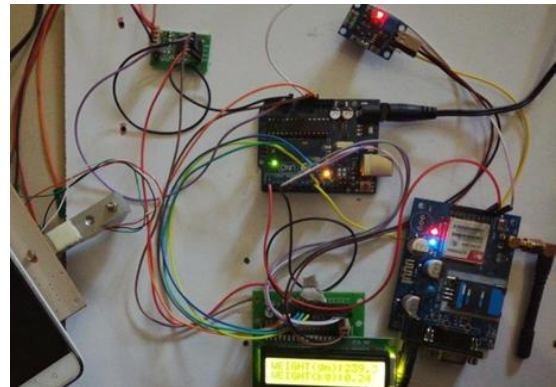

Fig.8 Signal Amplifier

**VI. HARDWARE RESULTS**

When the object is placed on the load cell and weight displayed on LCD.



**VII. CONCLUSION**

This work offers a design of fully automated home security system. Thus from this results conclude that this is one of the best option for the security purpose. Since all the component or device which are used in this work is very easily available and affordable to common people. We can also add few more sensors such as flame sensor etc. There is further enhancement possible with the help of advance technology such as WiFi, web server etc.

**REFERENCES**

1. Banik, A., Aich, B. Ghosh, S. (2018). Microcontroller based low cost gas leakage detector with SMS alert. Emerging Trends in Electronic Devices and Computational Techniques. doi:10.1109/edct.2018.840509. IEEE 2018.
2. Luay Friwan et al, "A Wireless Home Safety Gas Leakage Detection System", IEEE 2011.
3. Arpitha, T., Kiran, D., Gupta, V. S. N. S., & Duraiswamy, P. (2016). FPGA-GSM based gas leakage detection-system. 2016 IEEE. doi:10.1109/indicon.2016.7838952.
4. L. Fraiwan et al, "A wireless home safety gas leakage detection system," 1st Middle East Conference on Biomedical Engineering, 2011, pp. 11-14.