

# Stabilization of The Alternative Current in Wind Based Power Plant using Multi Order Harmonic Remover Based on Synthesized Multilayer Power Converter

Venugopal Reddy Bodha, Narasimha Raju Kuthuri, A. Srujana

*Abstract: Disregarding wind turbines has been conveyed an unmistakable fuel source and does not corrupt the air like other power assets, which relies upon consuming of petroleum products, for instance, coal or vaporous oil, since wind is a fluctuating wellspring of vitality it has experienced high request music and isn't fit to meet the base burden vitality request. Along these situation, this circumstance forces wind turbine generator system to have a power molding circuit called control converter that should be bore of changing the generator repeat and voltage to grid anyway existing converters are doing combating with low solicitation sounds just so when high request music occurs, there is a debasement in power quality and wind turbine needs single multi arrange converter. As to issue, this work showed a multi request symphonious remover subject to mixed multilayer influence converter which avoids high music bending to upgrade the influence idea of wind based influence plant by considering the going with attributes that prompts sounds, for instance, control adversity to adjust up to this expansion type rectifier is used, inadequacy current that is changed by imperfection current limiter and the high repeat part that is controlled using nonlinear inductor, at long last commotion is decreased by cascaded c type filter so this structure can battle with the high consonant mutilation and kept up the impact quality and the transient security of the wind turbine.*

*Index Terms: Bridge type rectifier, Fault current limiter, nonlinear inductor, cascaded c-type filter.*

## I. INTRODUCTION

Worlds primary energy consumption is met by the power sources, for example, non-renewable energy sources, atomic vitality and manageable power sources, for instance, hydro, daylight based, wind, geothermal power, bio empowers, etc. Petroleum derivatives are the non-inexhaustible assets while on consuming; it discharges colossal measure of vitality than the other type of vitality sources. Be that as it may, it take a great many years to frame, also the stores are being exhausted a lot quicker than the new ones are being made. Then again the atomic vitality is considered as a temperamental power source and it presents numerous dangers to the general population and the earth, for instance, prosperity perils and normal mischief from uranium mining, taking care of and

**Revised Manuscript Received on July 06, 2019.**

**Venugopal Reddy Bodha**, Research Scholar, EEE department, Koneru Lakshmaiah Education Foundation, Vaddeswaram, Guntur, India, 522502.

**Narasimha Raju Kuthuri**, Professor & HOD, EEE department, Koneru Lakshmaiah Education Foundation, Vaddeswaram, Guntur, India, 522502.

**A. Srujana**, Principal & professor, Sri venkateswara engineering college, Suryapet, Telangana-508213

transport, the risk of nuclear weapons development or harm, and the unsolved issue of radioactive nuclear waste. After the atomic issues endured by Japan, happened in March 2011 because of the seismic tremor and resulting tidal wave the requirement for development in security conditions and waste exchange on nuclear plants has raised costs and made nuclear imperativeness too much exorbitant, enabling new unlimited sources to be used [1]. In this setting the breeze imperativeness has been uncommon and displays the likelihood to contribute basically in heading off to the necessities on the costs of age, supply security and normal viability [2]. This is on the grounds that wind vitality is unlimited and inexhaustible. In contrast to traditional petroleum products, atomic vitality, and so on, wind energy is spotless and plentiful, that will be accessible for who and what is to come [3]. Anyway, wind speed is an exceptionally stochastic part which can go astray all around rapidly. By and large, inexhaustible sources regularly produce power and voltage fluctuating with normal conditions (wind speed, daylight and so on.) and matrix association of these sources. Be that as it may, Yield force of the Wind Energy change system (WECS) is with respect to the 3D square of wind speed, which causes the yield control instability in wind turbine. The power vacillation causes recurrence variance just as receptive power age or retention and voltage glint inside the power grid [4]. So as to lessen the power change, different power converter procedures have been proposed in the most recent decades so as to incorporate wind control into the electric grid [5]. The rule control quality disturbances caused as a result of the coordination of WECS to network are: assortment in power and music. To keep up structure synchronization and to keep all Total Harmonic Distortion (THD) inside operational limits, fitting control plans are required for the network side converter. The control plan used in system interfaced wind imperativeness change structure for generator side and grid side converter control, are surveyed in [6]. Voltage source converters (VSCs) are essentially used as unique interface between electric generators and the grid. With the creating in renewable, a strong research effort has been given, during the last more than ten years, to progress of control estimations that license VSCs to deal with the before referred to lattice disrupting impacts, for instance, symphonious twisting, ungainly nature, etc [7, 8]. Multi-megawatt wind turbine systems involve the establishment of reasonable based power age [9].



# Stabilization of The Alternative Current in Wind Based Power Plant using Multi Order Harmonic Remover Based on Synthesized Multilayer Power Converter

Relative major (PI) and PI + reverberating (PI + R) controller-based plans were immediately proposed to adjust either to inconsistent or twisted system voltage circumstances [10, 11]. The principal weaknesses nitty gritty for those plans are low-execution transient response, poor structure soundness, the necessity for isolating positive and negative progressions or/and symphonious sections of the framework voltage and besides of streams, in the particular occurrence of PI controllers, and nonappearance of power against parameter assortments [12]. In like way, solid courses of action reliant on direct power control (DPC) and DPC + full (DPC + R) controllers are used in [13, 14], having been devised to oversee cross section voltage unbalanced attributes. Notwithstanding the way that the issue of life against parameter deviations can be managed by applying those control suggestions, voltage deterioration in groupings is up 'til now required. Also, in DPC-based control frameworks, it is standard to course the power converters with variable trading repeat, along these lines confounding the structure of both the successive power converter itself and the AC consonant channel [15]. A couple of makers reinforce the sensibility of sliding-mode control (SMC) based designs for power devices applications. In any case, there exist different approaches to manage SMC, the going with three being probably the most regularly grasped: standard first-demand SMC (S1-SMC) [16], non-standard first-demand SMC (NS1-SMC), and second-demand SMC (2-SMC) [17]. In spite of the way that all of them lead to ground-breaking shut circle structures showing world class one of a kind responses, two are the essential impediments gambling handiness of the S1-SMC: specifically, the variable changing repeat to which it leads and the prattle impacting control factors. Before long, the NS1-SMC beats those issues by superseding the sign limit with a smooth similar limit, for instance, the inundation or the sigmoid limits [18]. The NS1-SMC-based course of action in [19] is affirmed unmistakably with the reenactment results [20]. Diverse particular issues similarly as the profitability of high-control wind imperativeness systems are analyzed in [21]. Thusly from the above depiction it is seen that to assemble the breeze essentialness change capability and to confine the consonant mutilation a novel framework must be upgraded with lessened mechanical load on wind turbines, improved network control quality to meet the grid codes and with refreshed high-control wind turbine advancement from fixed-speed to full-factor speed action. Along these lines the structure of the paper is organized where zone 2 depicts about the progressing related works associated with the proposed system, fragment 3 elucidates the proposed framework with explanations, portion 4 explains the results and trade of the proposed work with the present methods for similar objectives, section 5 explained with the end and sought after by references.

## II. LITERATURE SURVEY

In the progressing years, wind vitality has expected a basic employment in inexhaustible sources in order to limit the ecological outcome on power age all around the world. In this way WECS is significantly used to make control by changing over the breeze imperativeness into electrical essentialness. There are various methodologies falls into this change strategy and some of them are discussed underneath with their focal points and inconveniences Bhattacharjee et al.[22] have focused on an insightful extraction of ideal power and its dispatch by using fluffy rationale from a lattice tied crossover age including a perpetual magnet synchronous generator based breeze turbine and a low center photovoltaic generator. For photovoltaic generator, most prominent power point following control is executed using fluffy rationale under varying sun situated irradiance. Power expelled from

wind turbine is organized as a soft limit of the dc interface voltage botch, its rate of advancement and bumble in the prompt rotate current of the inverter. This diminishes high repeat movements in the breeze evacuated control. A failure mode and effect examination is cultivated for power converters and possible balance plans are proposed for different lacks. A 1:1 delta wye-grounded transformer is used at the inverter respect take out the triplet music. Han et al. [23] uses Brushless doubly-fed machine (BDFM), which is seen as a potential choice as opposed to the prominent doubly-fed induction machine (DFIM) in wind vitality change and electrical drive frameworks. Here a twofold stator brushless doubly-fed induction generator (DSBDFIG) is used to show its likelihood in wind essentialness applications. Regardless, isolated electric supply is urgent since there are up 'til now many weight centers, for instance, remote towns and islands that are separated from the rule framework. Baloch et al. [24] showing to adjust and look at wind essentialness change structure (WECS) by controlling the electrical repeat and stator voltage abundance of the squirrel-confine enlistment generator (SCIG) at discretionary breeze speed approach. It involves dynamic breeze turbine framework and 3-arrange SCIG unit. Regardless of the way that this way of thinking requires more research tries to deal with the consistent trial of the breeze turbine dynamic system and strength control with the computational assistance. Ali et al. [25] perturb and observe (P&O) methodology is exceptional MPPT framework in view of its straightforwardness and feasibility. Nevertheless, in light of high non linearity in ease and feasibility, P&O framework fails to pursue the most extraordinary power point and from this time forward presents high instabilities realizing low power yield. Tiwari et al. [26] passes on a close examination of different control strategies to isolate the most outrageous power from Permanent Magnet Synchronous Generator (PMSG) based Wind Energy Conversion System (WECS) with Fuzzy Logic Controller (FLC) under different breeze speed condition. Here the WECS involves a breeze turbine, a PMSG and a DC/DC converter which is related with a DC load. Regardless of the way that, it tracks the best power point effectively, it requires past data about structure aside from if the procedure gets bother in giving compelling constant state yield. Baranwal et al. [27] summed up transporter based PWM strategy for open-end winding motor drives that thoroughly clears out trading CMV. The proposed strategy is important to both twofold two-level voltage source inverter and twofold network converter based open-end winding drives. Distinct examination exhibits that the transporter based procedure requires basically less estimation stood out from the contrasting space vector execution. Leubner et al. [28] proposed a 2/3/4/ - step remuneration framework for direct three-level system converters (DTMC) in perspective on data arranges voltage estimation. While the DTMC is inspected since the beginning of the 21st century, the refinements in the reward to the quick cross section converter (DMC) has not been inquired about in detail. The extra reward ways lead to another game plan of limited state machines (FSM), which power the present stream to the neutral point ability of the channel capacitor. Concentrating on the yield voltage age, the substitution from and to the unprejudiced point potential will be locked in and the

known FSM for voltage-based substitution will be expanded. From the above writing study, it is found that the breeze essentialness change structure is used to change over wind imperativeness into electrical essentialness using power change system. During this power change there are some vexatious properties, for instance, voltage drop and corruption in the power quality in light of the weakness of the breeze essentialness. In this manner, the extension and decrease in the breeze speed will impact the voltage of the DC interface and on account of this there will happen of extended consonant contorting. Henceforth on considering the above communicated weaknesses in the present strategies there is a need to develop the structure of converter which will get correct the above deficiencies.

### III. SYNTHESIZED MULTILAYER POWER CONVERTER FOR MULTI ORDER HARMONIC REDUCTION

The wind energy transformation framework is used to change over wind vitality into electrical vitality using power change framework. It expects a key occupation in return of the fluctuating AC current into wanted network voltage. In any case, it is found in these change frameworks the period of wind power get impacted which hence diminishes the power system quality on account of the defenselessness thought of wind essentialness and voltage list. Thusly, the breeze speed is said to move with time causes eroticisms and evolving torque. Moreover increase/decrease in wind speed, will impact the voltage of the DC associate however on the off chance that the moved voltage is more noteworthy than the farthest point of the dc-interface, high sounds twisting is going on. Moreover, most of the converter uses nonlinear parts, for instance, the semiconductor switches, and direct open portions, for instance, the inductors, transformers and capacitors for transitional vitality accumulating similarly as present and voltage isolating; the size, weight and cost of the converter are, as it were, extended thusly this prompts defilement in power quality similarly as less transient quality. Thus, in order to adjust up to the above conditions, this work is generally focusing on organizing a solid converter which can administer enduring voltage, low sounds mutilation and getting reliable ideal transient stability. Thus, the Wind Power Generation appeared differently in relation to the next economical power sources have made at a quick pace. Most of the standard Power plants, Wind Power plants must ensure the idea of force passed on to the grid. Sounds are the most critical Power Quality Issues related to the Wind Power plants which happen on account of customary trading of the Power Converters and variable Wind speed. Thusly, this work has proposed a multi demand consonant remover subject to fused multilayer control converter which avoids high symphonious contortion in order to update the power idea of wind based power plant. Since this framework has considered the going with criteria control adversity, issue current and the high repeat portion, this structure can fight with the high consonant twisting and kept up the impact quality and the transient unflinching quality of the breeze turbine.

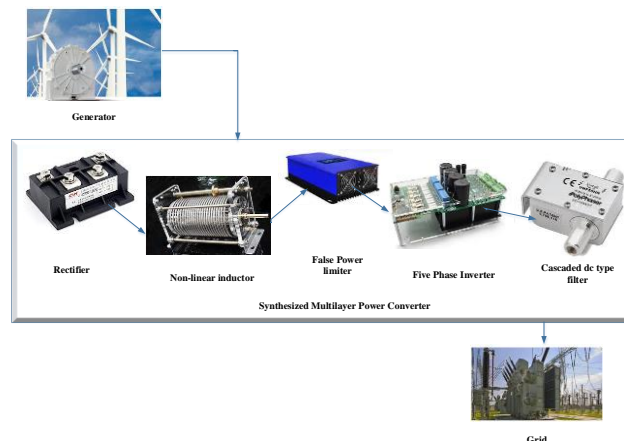


Fig. 1 The flow diagram of new model

The elective current from the plant was changed over into direct current with no power loss utilizing rectifier dependent on bridge type once in the past so as to obstruct the high recurrence part in the immediate current the nonlinear inductor is adjusted. A short time later, the bogus current is evacuated by consolidating Fault Power limiter. In the wake of evacuating the flaw, the immediate current just is allowed into the five stage inverter which converts the immediate current into the elective current. At long last, in the wake of changing over into elective current which is by all accounts progressively inclined to music in this way so as to expel that fell c type channel is adjusted. Subsequently, by along these lines the proposed framework has accomplished better power quality. In this way the working system of every part of the Synthesized Multilayer Power Converter is been depicted following and as an activity the Wind Source of Input is considered for the procedure. The Source of Input is being is considered to the procedure by methods for Wind harvesting through turbines.

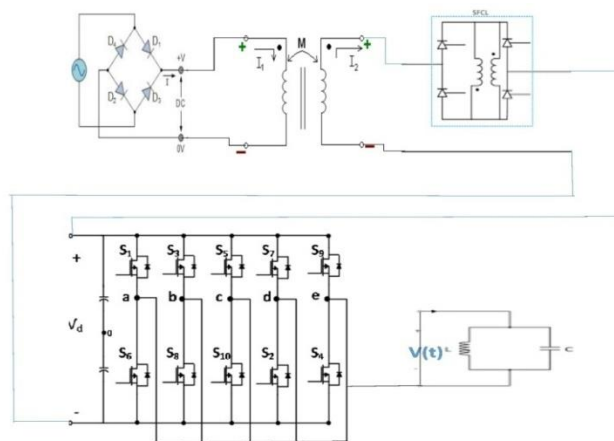


Fig.2 Schematic Diagram Synthesized Multilayer Power Converter

#### A. Wind Energy Input processing by turbine

WECS change the dynamic vitality of the breeze into electrical vitality or to some other structure. The WT isolates the kinetic energy (dynamic vitality) of the breeze and makes turning torque and the generator utilizing this torque produces electrical imperativeness, which is urged in to the lattice. WTs are of two sorts: vertical pivot and the even hub. Contemporary WTs generally utilize the



# Stabilization of The Alternative Current in Wind Based Power Plant using Multi Order Harmonic Remover Based on Synthesized Multilayer Power Converter

dimension turn plan having a couple of sharp edges, which work either down-wind or up-wind. A WT will be expected to work for a fixed speed or variable speed. More vitality is made by factor speed WTs interestingly with fixed speed WTs; regardless, they require control electronic converters to empower a relentless repeat and reliable voltage electrical vitality yield. Riggings instrument is secured for planning the quick 3- $\Phi$  AC generators with the low speed WT. Generators utilized for WTs will be of the sorts: alternators, perpetual magnet synchronous generators (PMSG) and IGs of two sorts: the squirrel pen and wound rotor. Reliability and insignificant exertion made PMSG and squirrel confine IGs surely understood in nearly nothing and medium evaluated WTs. In this paper, predictable speed with pitch control WT is used. The IG is used in this paper by virtue of its clear and extreme improvement, moderate, no need of disconnected excitation circuit, and has trademark security for short out. The hard and fast power available in the breeze is given by the condition,

$$P_w = \frac{1}{2} \rho A v_w^3 \quad (1)$$

Where A is the exposed area in m<sup>2</sup>,  $\rho$  is the density of the air in kg/m<sup>3</sup> is the wind speed in m/s. For recovering total KE of wind, wind velocity shall be reduced to zero, which causes no air flow through the wind turbine. Thus it excerpts a portion of power in wind, given by the equation,

$$P_m = C_p P_w \quad (2)$$

Be that as it may, an IG takes slacking flows for charge, powers the source to supply the required responsive power. Along these lines the source has the extra weight of providing receptive capacity to stack just as to IG. Where  $C_p$  is called control coefficient of the WT. The breeze is changed over to mechanical power with a productivity  $C_p$ , and transmitted precisely to the generator with proficiency  $\eta_m$ , and further changed over to power with an effectiveness  $\eta_g$ . The electrical power yield is at that point

$$P_e = C_p \eta_m \eta_g P_w \quad (3)$$

## B. Bridge type rectifier

Since AC current isn't suitable for testing because of vulnerability about the presence of harmonics or not. In this manner, the AC current must be converted to DC current for that a bridge type rectifier is used. The ultimate application of bridge circuit configuration is that it doesn't acquire a expensive center tapped transformer, along these lines diminishing its expense and size. Along these lines, the DC yield sign of the bridge type rectifier is smoother than different rectifiers so it can manage ripples. The bridge type rectifier is comprised of four diodes to be specific D1, D2, D3, D4 and resistor load  $R_L$ . The four diodes are associated in shut circle arrangement to proficiently change over the AC current into DC current. The DC yield sign of the extension rectifier is smoother than different rectifiers so it can manage ripples.

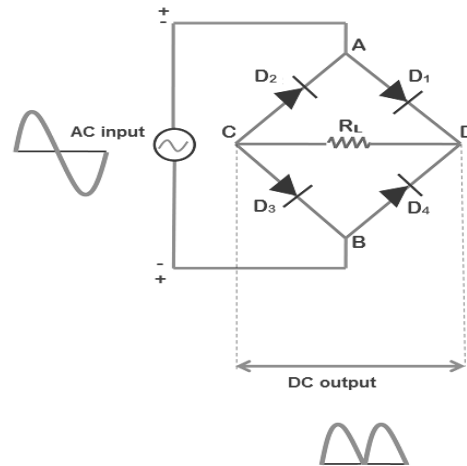


Fig. 3 Bridge type rectifier model

The input alternate current (AC) signal is associated crosswise over more than two terminals A and B and the yield DC sign is gotten over the heap resistor  $R_L$  which is related between the terminals C and D. The four diodes D1, D2, D3, and D4 are orchestrated in arrangement with only two diodes allowing electric stream during each half cycle. Right when information AC sign is associated over the scaffold type rectifier, during the positive half cycle diodes D1 and D3 are forward uneven and licenses electric stream while the diodes D2 and D4 are pivot uneven and squares electric stream. On the other hand, during the negative half cycle diodes D2 and D4 is forward uneven and licenses electric stream while diodes D1 and D3 are switch uneven and square electric flow. During the positive half cycle, the terminal A breezes up positive while the terminal B winds up negative. This causes the diodes D1 and D3 forward uneven and meanwhile, it causes the diodes D2 and D4 invert one-sided.

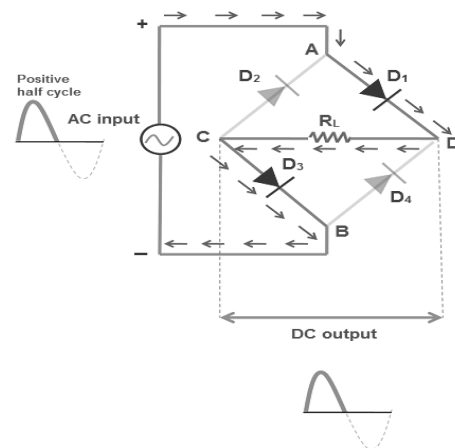


Fig. 4 The positive half cycle of rectifier

The present stream course during the positive half cycle is showed up in the figure that is (A to D to C to B) during the negative half cycle, the terminal B ends up positive while the terminal A winds up negative. This causes the diodes D2 and D4 forward one-sided and meanwhile, it causes the diodes D1 and D3 switch one-sided.

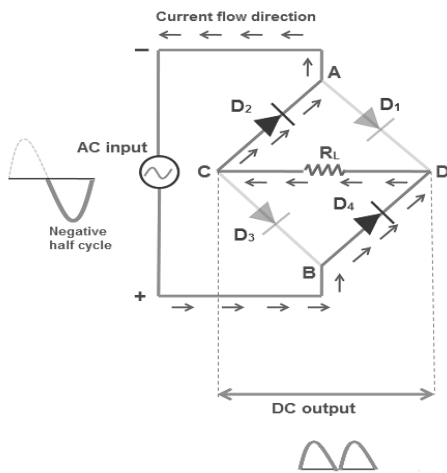


Fig. 5 Negative half cycle of a rectifier

The present stream course during negative half cycle is showed up in the figure that is (B to C to C to A), Since the way of present stream load resistor  $R_L$  is same throughout the positive half cycle and negative half cycle, the polarization of the yield DC signal is similar for both positive and negative half cycles. The yield DC signal extremity might be either absolutely positive or negative.

C. Non Linear conductor

Progressively, the output of the bridge type rectifier is bolstered to the nonlinear inductor to up accompany the high frequency segments which cause harmonics. Here an inductive component which its inductance may differ because of center impact affected by magnetic field.

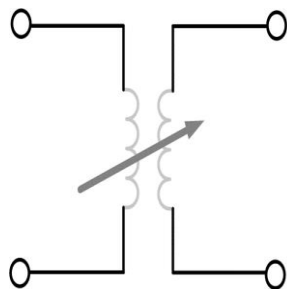


Fig. 6 Non-Linear Conductor

D. Fault current limiter

Despite the fact that, the direct current is processed for removing harmonics present, the variables, for example, high frequency components and the power loss, harmonics arise because of flaw current are still to be removed for this reason, this work has used a fault current limiter to evacuate the fault current. A fault current limiter avoids current in an electrical circuit from surpassing the foreordained level by expanding the electrical impedance of that circuit before the current in the circuit surpasses that level. Fault current limiters are planned in order to limit the impedance of the circuit under ordinary conditions to decrease losses, however builds the impedance of the circuit under fault conditions to limit fault current. The FCL with series compensation has the going with particular characteristics which isn't constrained by the customary current limiters,

a) Quick current obliging by the strong state switch control. The strong state switch gives snappier insurance than mechanical switches, yet also gives speedier restarting of series compensation

b) No power misfortune in the solid-state switch. Power framework gadgets using semiconductor contraptions experience control misfortune in the semiconductors. Regardless, the FCL does not pass a heap current through the solid state switch so no power misfortune develops under customary assignment.

c) Simultaneous current confining and capacitor insurance. Bypassing the arrangement capacitor for current confining can in like manner alleviate the overvoltage of the capacitor.

d) Improved gadget use rate by series compensation. A conventional current limiter gives simply weakness current obliging and does not work, except for on insufficiency occasion. The FCL gives arrangement pay under standard assignment.

e) Improved transmission breaking point and structure consistent quality.

A present obliging gadget which just restricts the lack current that can't assemble the power transmission capacity to more than that of the structure steady state soundness. The FCL can update the security locale by arrangement pay.

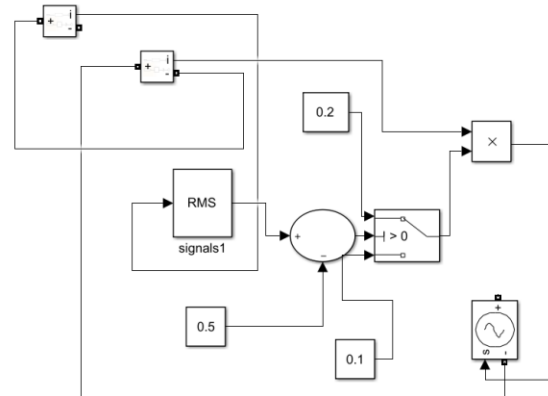


Fig. 7 Single Fault current limiter

E. Five phase inverters

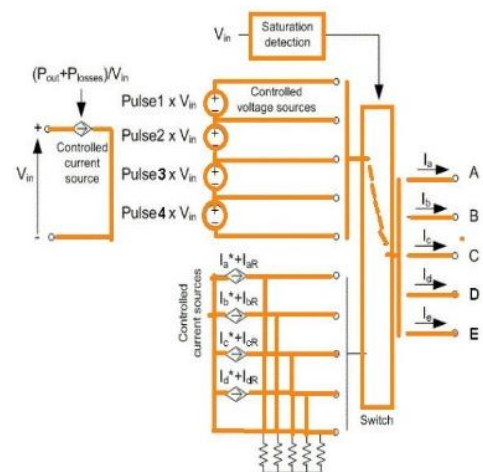


Fig. 8 Five phase inverter

After the evacuating harmonics the direct present should be again changed over into elective current before offering it to the matrix board so the output of the flaw current limiter is bolstered to the five-stage based inverter



# Stabilization of The Alternative Current in Wind Based Power Plant using Multi Order Harmonic Remover Based on Synthesized Multilayer Power Converter

which can adapt up to the harmonic substance well and it further diminished the functional complexity of the channel.

## F. Cascaded C-type filter

After converting the direct current into an alternative current by five phase based inverter there is a chance of occurring noises that causes harmonics so this work has employed a cascaded c type filter which removes the harmonics optimally. The filter impedance is given by

$$Z_F = \frac{j\omega L_2 - j\frac{1}{\omega C_2} * R_T}{R_T + j\omega L_2 - j\frac{1}{\omega C_2}} - j\frac{1}{\omega C_1}$$

The L2 and C2 components are tuned to the fundamental frequency

$$L_2 = \frac{1}{\omega_1^2 C_2}$$

Therefore

$$Z_F = \frac{jR_T(\omega^2 - \omega_1^2)}{R_T\omega\omega_1^2 C_2 + j(\omega^2 - \omega_1^2)} - j\frac{1}{\omega C_1}$$

The c-type filter is tuned to the resonance angular frequency

$$\omega_r = \frac{1}{\sqrt{L_2 \frac{C_1 C_2}{C_1 + C_2}}}$$

Hence

$$Z_F = \frac{jR_T(\omega^2 - \omega_1^2)}{R_T\omega\omega_1^2 C_1(n_r^2 - 1) + j(\omega^2 - \omega_1^2)} - j\frac{1}{\omega C_1}$$

The filter reactive power QF for the fundamental harmonic is given by the relation

$$Q_F = -\frac{U^2}{I_m(Z_F(\omega_1))} = C_1 = \frac{Q_F}{\omega_1 U^2}$$

That is

$$Z_F = \frac{jR_T U^2(\omega^2 - \omega_1^2)}{R_T\omega\omega_1^2 Q_F(n_r^2 - 1) + jU^2(\omega^2 - \omega_1^2)} - j\frac{\omega_i U^2}{\omega Q_F}$$

Distribution of the load generated harmonic current between the filter tuned to that harmonic and the system is

$$\frac{I_S(n_r)}{I_F(n_r)} = K = \frac{|Z_F(n_r)|}{|Z_S(n_r)|}$$

$$R_T = \frac{U^2}{n_r^3 Q_F^2 k \omega_1 L_s} \sqrt{U^4 - n_r^4 Q_F^2 K^2 \omega_1^2 L_s^2}$$

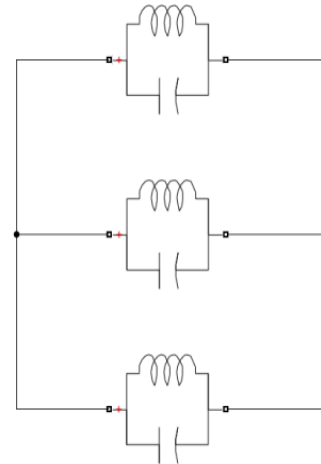


Fig. 9 The Cascaded c type filter

## IV. RESULT AND DISCUSSION

In this exploration work, the recreations of Permanent Magnetic Synchronize Generator (MSG) with multi request symphonious remover dependent on orchestrated multilayer control converter for the sustainable breeze control frameworks are displayed. Recreations have been finished utilizing MATLAB' Simulink.

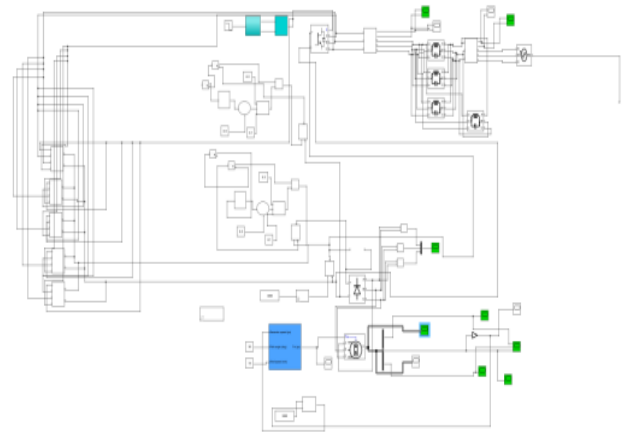


Fig. 10 Preview Design for the Proposed Model

The below figure shows the results of permanent magnet synchronous machine

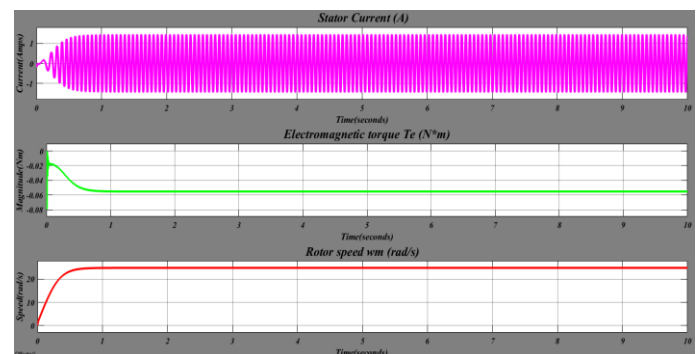
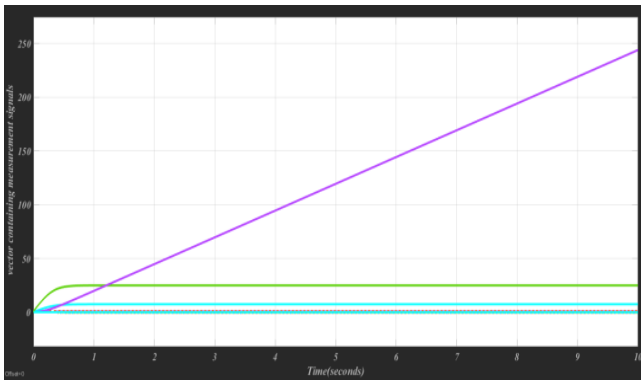


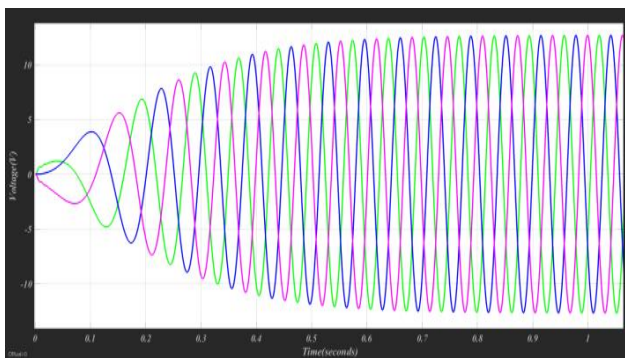
Fig. 11 Output of Stator Current, Electromagnetic torque and Rotor speed PMSM



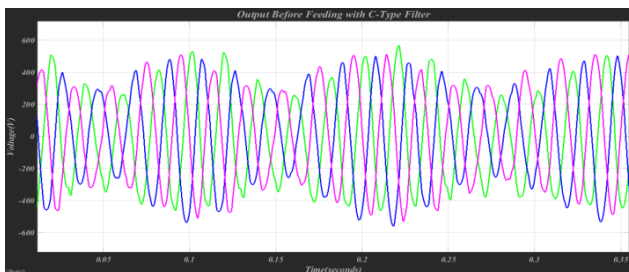
**Fig. 12 Output of magnitude from the Synchronous Permanent Magnet Machine**

**Single phase fault current limiter:**

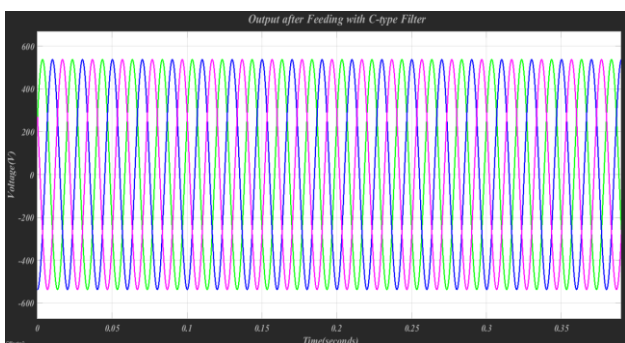
This performs limiting current fault arising in the phases; the table shows the current limited values;



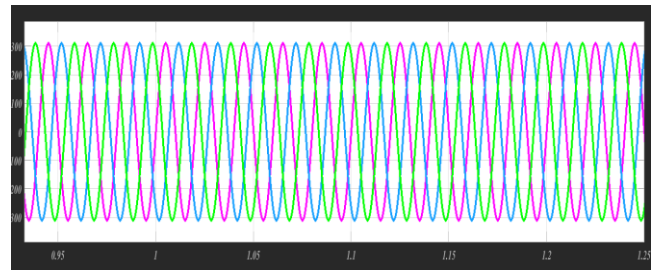
**Fig. 13 Output of voltage after feeding with Fault Current Limiter**



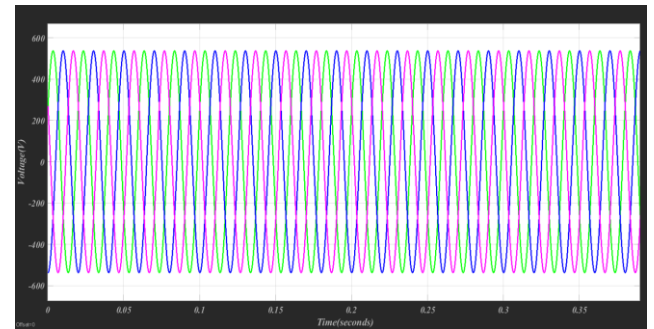
**Fig. 14 Output before Feeding into the C-Type Filter**



**Fig. 15 Output after Feeding with C-Type Filter**



**(a) Voltage output with transformer**



**(b) Voltage output without transformer [proposed]**

**Fig. 16 Voltage Stability for the Existing and Proposed Method**

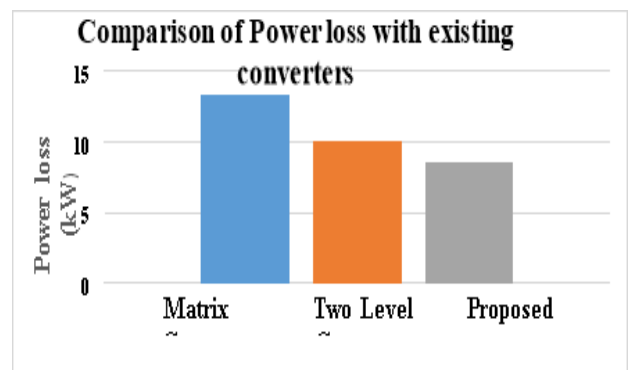
The above shows the resultant graph obtained as a result of not using transformer. The result shows that voltage graph obtained is in par with, not using transformer.

**A. Performance measure**

To show the efficiency of the developed model, the following sections deals with comparison with other methods. In terms of power loss:

**Table 1: Values for The Comparison of Proposed Converter with Existing Converters**

Parameter	Matrix converter [28]	Two level converters [27]	Proposed
Efficiency	93	94.7	96.3
Utilization Factor	0.081	0.078	0.095
Power Loss	13.3	10	8.6



**Fig. 17 Comparison plot for Power Loss**



# Stabilization of The Alternative Current in Wind Based Power Plant using Multi Order Harmonic Remove Based on Synthesized Multilayer Power Converter

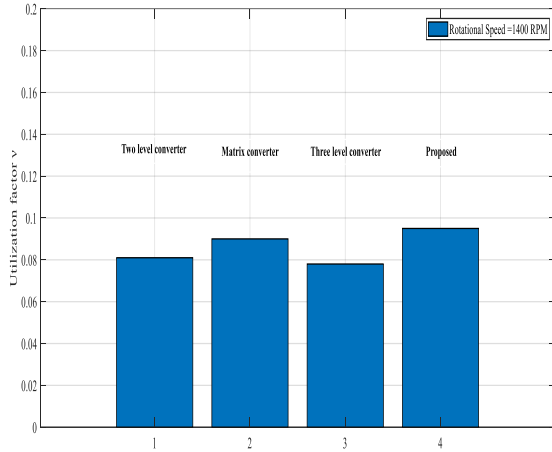


Fig. 18 Comparison plot for Utilization factor

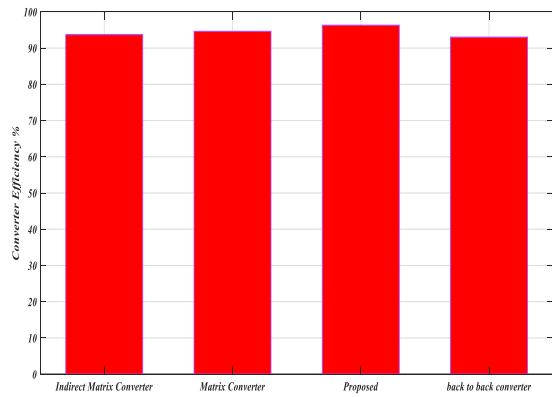


Fig. 19 Comparison plot for Converter Efficiency

The proposed framework has gotten better outcome regarding converter proficiency, usage factor and as far as power misfortune when contrasted and the current components, for example, consecutive converter, aberrant network converter, lattice converter and staggered converter. The disadvantages of existing systems are recorded beneath.

### Drawbacks of matrix converter

The DC-interface voltage would not benefit from outside intervention as that of consecutive converter. Without entering the over guideline go, the best yield voltage of the system converter is 0.866 events the data voltage.

- To achieve a comparative yield control as the consecutive converter, the yield current of the system converter must be 1.15 events higher, offering climb to higher coordinating misfortunes in the converter.
- Due to the nonappearance of the DC-interface, there is no decoupling between the information and yield of the converter. In flawless terms, this isn't an issue yet because of inconsistent or ruined data voltages, or uneven weight, the data current and the yield voltage in like manner ended up being curved.
- Modulation framework and substitution control are more jumbled than those in the standard PWM inverter.
- The confirmation of the system converter in an inadequacy situation isn't on a standard with that of back to back converter.

### Impediments of back to back converter:

The closeness of the generous and fault DC-interface capacitor extends the costs and diminishes the general lifetime of the system

- Another huge drawback of the consecutive converter is the trading setbacks. Each back o back, in both the system inverter and the generator inverter between the upper and lower DC-connect branch is connected with a hard trading and a trademark substitution
- The back to back converter contains two inverters, so the trading setbacks might be impressively progressively explained
- The high changing rate to the matrix may likewise require additional EMI-channels, and
- The consolidated control of the controlled rectifier and inverter is very convoluted.

### Disadvantages of Multilevel converter:

Requires a number of semiconductor devices, which increases the complication of the control circuit, the voltage inequality among the upper and the lower DC-link capacity, uneven current pressure on the semiconductors.

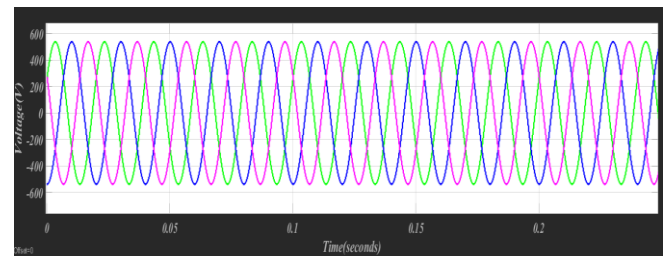


Fig. 20 Voltage output obtained for the existing model

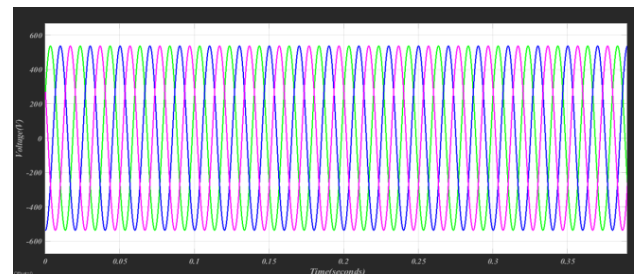


Fig. 21 Voltage output obtained for the proposed model

Since the proposed system has followed systematic conversion of generated power source such that power loss is controlled by the bridge type rectifier and subsequently high frequency components and faults currents are mitigated by nonlinear inductor and fault current limiter and finally noise also removed by the cascaded c type filter so it has maintained the voltage stability even when there is high order harmonics is arising.

### B. Error Analysis

#### (i)RMSE

The RMS value of a collection of values is the square root of the arithmetic mean of the squares of the values, or the square of the function that defines the discrete waveform. The error occur during the continuous waveform function is defined as RMSE.

$$RMSE = \sqrt{\frac{1}{n}(y_1^2 + y_2^2 \dots y_n^2)} \quad (4)$$

**(ii) MSE**

The mean squared error (MSE) of an estimator calculates the average of the squares of the errors that is the average squared difference between the estimated values and is estimated.

$$MSE = \frac{1}{n} \sum_{i=1}^n (y_i - y_i')^2 \quad (5)$$

**(iii) Steady-state error**

Steady-state error is defined as the difference between the input and output of a system in the limit as time goes to undetermined.

$$e(\xi) = \lim_{s \rightarrow 0} \frac{sR(s)}{1 + G(s)} \quad (6)$$

**Table 2: Error Analysis of Proposed System**

Method	RMSE	MSE	Steady state error	
			V	I
Proposed system	0.165	0.029732	2.721	3.711

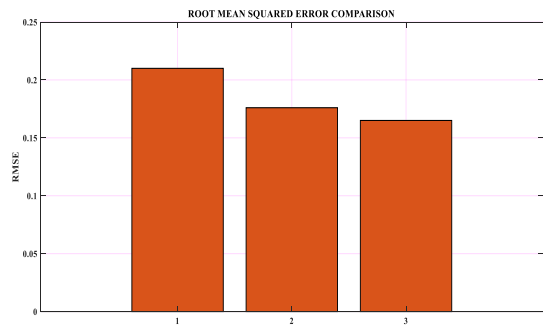
The error analysis of the proposed methodology SMG-MHSVSC resulting in RMSE value be 0.165, MSE value be 0.029732 and the steady state error value be with respective to voltage be 2.721 and with current be 3.711.

1. Comparison of Error analysis

**Table3: Comparison of Error Analysis with Proposed System**

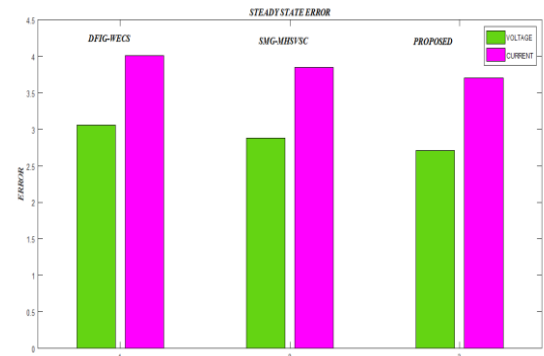
METHOD	RMSE	MSE	STEADY STATE ERROR	
			V	I
DFIG-WECS	0.21	0.0041	3.06	4.012
SMG-MHSVSC	0.176	0.030976	2.887	3.849
PROPOSED	0.165	0.029732	2.721	3.711

Thus by above stated table explains that the DFIG-WECS error parameters such as RMS has value of about 0.21, MSE value of about 0.0041 and the steady state error with respective to Voltage be 3.06 and current be 4.012. By analyzing the existing SMG-MHSVSC has little better efficiency property in turn the error happening is stated to condensed such that the RMS value is stated as 0.176, MSE value is about 0.030976 and the steady state error value with respective voltage and current be 2.887 and 3.849 but the proposed system has obtained the values 0.165, 0.029732, 2,721, 3,711 for the parameters RMSE, MSE, V and I respectively.

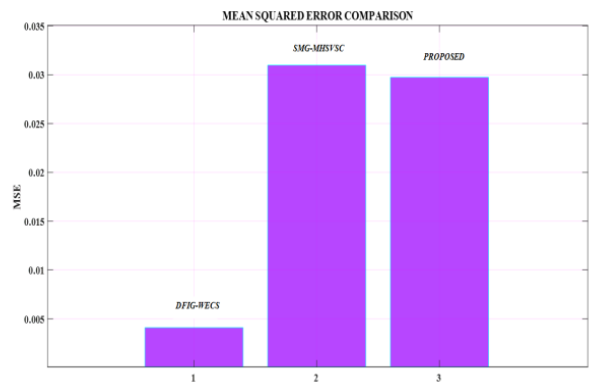


**Fig. 22 Comparison for Root Mean Square Error**

From fig 23 to 24 demonstrates the investigation of the proposed framework alongside the accompanying existing systems, for example, DFIG-WECS and SMG-MHSVSC.



**Fig.23 Comparison for Mean Square Error**



**Fig. 24 Comparison for Steady State Error**

The acquired outcomes has demonstrated that the proposed framework has accomplished better root mean square blunder and the mean square mistake since it has pursued a methodical change of intensity produced from the DFIG based breeze turbine to such an extent that for keeping up the low power misfortune, it has adjusted a scaffold type rectifier, for adapting to the high recurrence segments, it has utilized nonlinear inductor and for false current just as clamor, it has adjusted issue current limiter and the fell c type channel individually, By along these lines the proposed framework has accomplished better evacuation of both low request and high request



# Stabilization of The Alternative Current in Wind Based Power Plant using Multi Order Harmonic Remover Based on Synthesized Multilayer Power Converter

## V. CONCLUSION

Harmonics cause issues, for example, abundance warming, increasingly acoustic clamor, torsion vibration of motor shaft, compensation issues in DC engines, and so on. Existing systems have utilized VFD (Variable Frequency Drive) engines and transformer however these components has incited engine warming at low speed and initiated electrical cable music this prompts corruption in execution of other hardware associated with a similar supply is truly influenced. Since the proposed framework in this work has considered the accompanying criteria control misfortune, shortcoming current and the high recurrence segment and pursued by the efficient transformation, this framework can battle with the high consonant contortion and kept up the transient quality and the transient solidness of the wind turbine.

## REFERENCES

1. T.R. de Freitas, P.J. Menegáz, and D.S. Simonetti, "Rectifier topologies for permanent magnet synchronous generator on wind energy conversion systems: A review," *Renewable and Sustainable Energy Reviews*, vol.54, pp.1334-1344, 2016.
2. M. Naidoo, and A. Gasparatos, "Corporate Environmental Sustainability in the retail sector: Drivers, strategies and performance measurement," *Journal of Cleaner Production*, vol.203, pp.125-142, 2018.
3. E. Kabir, P. Kumar, S. Kumar, Adelodun, and K.H. Kim, "Solar energy: Potential and future prospects," *Renewable and Sustainable Energy Reviews*, vol.82, pp.894-900, 2018.
4. M.G. Molina, and P.E. Mercado, "Renewable Energy Technologies for Microgrids," In *Microgrids Design and Implementation*, pp. 27-67, 2019.
5. D. Arcos-Aviles, J. Pascual, L. Marroyo, P. Sanchis, and F. Guinjoan, "Fuzzy logic-based energy management system design for residential grid-connected microgrids," *IEEE Transactions on Smart Grid*, vol.9, no.2, pp.530-543, 2018.
6. B. Jain, S. Jain, and R.K. Nema, "Control strategies of grid interfaced wind energy conversion system: An overview," *Renewable and Sustainable Energy Reviews*, vol.47, pp.983-996, 2015.
7. A. Gupta, S. Doolla, and K. Chatterjee, "Hybrid AC-DC microgrid: systematic evaluation of control strategies," *IEEE Transactions on Smart Grid*, vol.9, no.4, pp.3830-3843, 2018.
8. A. Joseph, and T.R. Chelliah, "A review of power electronic converters for variable speed pumped storage plants: Configurations, operational challenges, and future scopes," *IEEE Journal of Emerging and Selected Topics in Power Electronics*, vol.6, no.1, pp.103-119, 2018.
9. E. Kabalci, and Y. Kabalci, "Introduction to Smart Grid Architecture," In *Smart Grids and Their Communication Systems*, pp. 3-45, 2019.
10. M.I. Martinez, A. Susperregui, and G. Tapia, "Second-order sliding-mode-based global control scheme for wind turbine-driven DFIGs subject to unbalanced and distorted grid voltage," *IET Electric Power Applications*, vol.11, no.6, pp.1013-1022, 2017.
11. M. Hadidian Moghaddam, A. Kalam, M. Miveh, A. Naderipour, F. Gandoman, A. Ghadimi, and Z. Abdul-Malek, "Improved Voltage Unbalance and Harmonics Compensation Control Strategy for an Isolated Microgrid," *Energies*, vol.11, no.10, p.2688, 2018.
12. Y.V. Singh. "Motor Integrated Variable Speed Drives," (Doctoral dissertation, Department of Energy Technology, Aalborg University), 2015.
13. S. Chatterjee, and S. Chatterjee, "Review on the techno-commercial aspects of wind energy conversion system," *IET Renewable Power Generation*, vol.12, no.14, pp.1581-1608, 2018.
14. A.S. Abdel-Khalik, A.M. Massoud, and S. Ahmed, "Effect of DC-link voltage limitation on postfault steady-state performance of asymmetrical six-phase induction machines," *IEEE Transactions on Industrial Electronics*, vol.65, no.9, pp.6890-6900, 2018.
15. T. Kamal, M. Karabacak, S.Z. Hassan, L.M.F. Ramirez, I. Roasto, and L. Khan, "An Indirect Adaptive Control Paradigm for Wind Generation Systems," In *Advanced Control and Optimization Paradigms for Wind Energy Systems*, pp. 235-257, 2019.
16. X. Liu, Y. Han, and C. Wang, "Second-order sliding mode control for power optimization of DFIG-based variable speed wind turbine," *IET Renewable Power Generation*, vol.11, no.2, pp.408-418, 2016.
17. S. Jupin, I. Vechiu, and G. Tapia, "Direct state-space model for model predictive control of multi-level power converters", In *IECON 2017-43rd Annual Conference of the IEEE Industrial Electronics Society*, pp. 7759-7764, 2017.
18. A. Msaddek, A. Gaaloul, F. Sahli, "Comparative study of higher order sliding mode controllers," *Proc. 15th IEEE Int. Conf. on Sciences and Techniques of Automatic Control and Computer Engineering (STA)*, Hammamet, Tunisia, pp.915-922, 2014.
19. S. Xia, Q.Zhang, S.T. Hussain, B. Hong, and W. Zou, "Impacts of integration of wind farms on power system transient stability," *Applied Sciences*, vol.8, no.8, p.1289, 2018.
20. M.I. Martinez, A. Susperregui, and G. Tapia, "Second-order sliding-mode-based global control scheme for wind turbine-driven DFIGs subject to unbalanced and distorted grid voltage," *IET Electric Power Applications*, vol.11, no.6, pp.1013-1022, 2017.
21. Tabar, Wahid Sohrabi, Saeid Ghassemzadeh, and Sajjad Tohidi, "Energy management in hybrid microgrid with considering multiple power market and real time demand response," *Energy*, vol.174, pp.10-23, 2019.
22. C. Bhattacharjee, and B.K. Roy, "Advanced fuzzy power extraction control of wind energy conversion system for power quality improvement in a grid tied hybrid generation system," *IET Generation, Transmission & Distribution*, vol.10, no.5, pp.1179-1189, 2016.
23. P. Han, M. Cheng, X. Wei, and N. Li, "Modeling and performance analysis of a dual-stator brushless doubly fed induction machine based on spiral vector theory," *IEEE Transactions on Industry Applications*, vol.52, no.2, pp.1380-1389, 2016.
24. M.H. Baloch, J. Wang, and G.S. Kaloi, "Stability and nonlinear controller analysis of wind energy conversion system with random wind speed," *International Journal of Electrical Power & Energy Systems*, vol.79, pp.75-83, 2016.
25. A.I. Ali, M.A. Sayed, and E.E. Mohamed, "Modified efficient perturb and observe maximum power point tracking technique for grid-tied PV system," *International Journal of Electrical Power & Energy Systems*, v ol.99, pp.192-202, 2018.
26. R. Tiwari, and N.R. Babu, "Fuzzy logic based MPPT for permanent magnet synchronous generator in wind energy conversion system," *IFAC-Papers On Line*, vol.49, no.1, pp.462-467, 2016.
27. R. Baranwal, K. Basu, and N. Mohan, "Carrier-based implementation of SVPWM for dual two-level VSI and dual matrix converter with zero common-mode voltage," *IEEE Transactions on Power Electronics*, vol.30, no.3, pp.1471-1487, 2015.
28. M. Leubner, N. Remus, S. Schwarz, and W. Hofmann, "Voltage based 2/3/4-step commutation for direct three-level matrix converter," In *2018 IEEE Applied Power Electronics Conference and Exposition (APEC)*, pp. 2507-2514, 2018.