

Design of a Single Phase Inverter for Aircraft Applications

Ozwin Dominic Dsouza, Prajwal, Arjun S, Manjunath, Tassmiya

Abstract: This paper explains the design of inverter for aircraft application. Inverter is designed using the H-bridge connection of MOSFET. Gate voltage of the MOSFET is controlled by using arduino and mosfet driver connection. Designed inverter will support for 400Hz load. Inverted 400Hz voltage is displayed in 16*2 LCD display using the opto-coupler connection. This is the cost effective inverter design for high frequency application.

Index terms: PWM, MOSFET, H-bridge, Opto-coupler.

I. INTRODUCTION

Now a days the aircraft are highly depends upon the electrical power for communications, navigation and control. Identification lights, landing lights, instrument lights, heaters, retractable landing gear, wing flaps, engine cowl flaps, radio, and navigation equipment and so on are the electrical loads for the aircraft. Electrical power for aircraft mainly supplied by the generator coupled to the engine, and also electrical power supplied by batteries for back-up system. So inverter plays a vital role in the power supply for the aircraft application. Flight control and different PCs request the conveyance of dependable, uninterrupted power. The acquaintance of low drain motors with increment unwavering quality, practicality, and harm resilience capacities has brought about diminished pneumatic power accessibility. This, alongside the substitution of hydraulic systems and accessories with electric equipment, has led to the requirement for bigger electricity producing system. Since the late 1940s, the predominant technique for creating and circulating electric power on aircraft has been, and is in the process of being; 400 Hz three phase 115 V AC. This type of power is suitable for transmission throughout the aircraft without excessive penalties for feeder weight [1]. 28VDC Electrical powers also available in most of the aircraft. This type of power is compatible with batteries. It is therefore utilized for critical loads. Dmitriy Y.

Manuscript Received on July 09, 2019

Ozwin Dominic Dsouza, Assistant Professor in the department of Electrical and Electronics Engineering at BMS Institute of Technology and Management.

Prajwal Shetty, pursuing his Bachelor in Engineering in Electrical and Electronics Engineering department at BMS Institute of Technology and Management Bengaluru.

Arjun S, pursuing his Bachelor in Engineering in Electrical and Electronics Engineering department at BMS Institute of Technology and Management Bengaluru.

Manjunath pursuing his Bachelor in Engineering in Electrical and Electronics Engineering department at BMS Institute of Technology and Management Besngaluru.

Komovskiy presented a review of two and three-level voltage inverter schemes as a part of alternating current electric energy generation system of constant frequency for aircraft [2]. This presents results of modelling of two and three -level voltage inverters.

The dymola platform based aviation static inverter [3] is presented by Wenjing Zhang, Xiaobin Zhang, Wenjie Liu, Weilin Li. This paper provides reference for the design of aircraft power system.

$$XL = 2\pi fL \quad (1)$$

From equation (1) Inductance is given by

$$L = \frac{XL}{2\pi f} \quad (2)$$

Equation (2) shows that inductance is inversely proportional to the frequency i.e., $L \propto \frac{1}{f}$

Therefore as the frequency increases inductance decrease.

According to the inductance formula

$$L = \frac{N^2 \mu A}{l} \quad (3)$$

Equation (3) shows that inductance is directly proportional to the area i.e., $L \propto A$

According to the above discussion, as frequency increases - inductance decreases, as inductance decreases – inductance area decreases. So if we increase the frequency inductance size will decrease. So in aircraft application to decrease inductance size 400Hz frequency voltages are used.

And also the transformer equation is given by

$$V = 4.44f\Phi T \quad (4)$$

According to Equation (4) if frequency increases – flux decrease for a fixed V.

The flux is $\Phi = EA$ (5)

According to Equation(4) & (5) as the frequency increases the size of the load that are connected to supply will reduced. Many loads (like motor, compressor, etc) are used in aircraft application, so to decrease the load size 400Hz are used in aircraft application.

Yanbo Che proposed an inverter model based on generalised space vector modelling [4].In this work he compared the results of generalised space vector modelling with state space averaging and time domain simulation.

Aircraft system:

Weight of the components highly effects in aircraft system. We have to consider the weight of each component which are used in aircraft application, as the weight decreases the number of components increases and also availability of space increases. According to the Inductive reactance (XL) formula

II. SUBSYSTEM DESCRIPTION

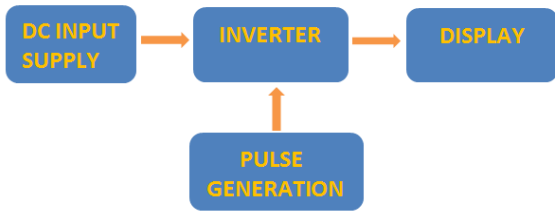

a. Block diagram

A. DC POWER SUPPLY:

In this work we have used two types of DC power supply. One 5V DC power supply, to energize the arduino board and another 12V DC power supply which is inverted

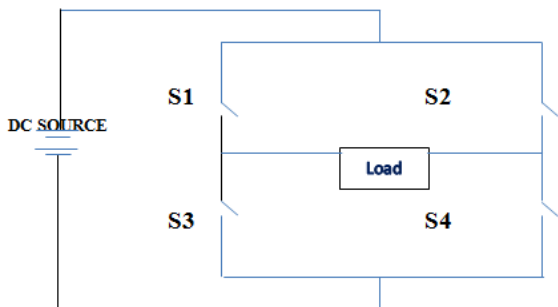

b. H-bridge connection

from DC to AC through inverter section. Two arduino boards are used in work; both are supplied by a 5V supply. 12V DC battery is used in inverter section.

B. INVERTER SECTION:

Inverters are used to convert DC power into AC power. Usually we will get DC power from a battery but many electronics equipment are work on AC power, so to convert DC power to AC power inverter are used. In this project we are using H-bridge concept to carry out inverter action(Figure b). Fig b shows a H-bridge connection to a load. In H bridge connection at starting, to get positive half cycle of AC output switch S1, S4 are closed and S2, S3 are open. And to get negative half cycle of AC output switch S2, S3 are closed and S1, S4 are open. In our project we select the MOSFET to carry out switching action. MOSFET will act as switch that is when a signal is applied to the gate, they turn on and then turn off when the signal is removed.

C. MOSFET :

A MOSFET is a voltage controlled device and requires only small input current. The switching speed is very high and the switching times are of the order of nanoseconds. Power MOSFET's find increasing applications in low power high frequency application. IRF540 MOSFET is used in this project. This MOSFET can drive loads up to 23A and can support peak current up to 110A. It also has a threshold voltage of 4V, which means it can easily driven by low voltages like 5V. Hence it is mostly used with Arduino and other microcontrollers for logic switching.

As mentioned above the MOSFET gate voltage is controlled by train of pulses. If gate pulse is a positive pulse, N channel MOSFET will conduct otherwise for negative pulse P channel MOSFET conducts. According to H bridge connection during positive gate pulse, positive cycle of AC output voltages are

obtained and during negative pulse, negative cycle of AC output voltages are obtained. Based on this principle inverter actions are carried out in H Bridge.

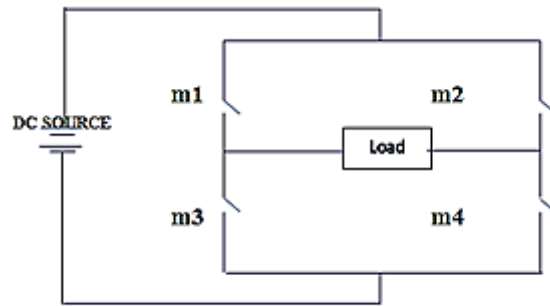

c. MOSFET location

E. PULSE GENERATION



d. Arduino

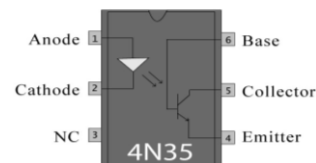

e. Optocoupler pindigram

Pulses are generated using arduino section. Microcontroller ATmega328 is used in arduino section. According to uploaded program microcontroller will generate the pulse, we can change pulse by changing loaded program. Generated pulsed are transmitted to MOSFET driver. Transistor BC547 is used as the MOSFET driver.

F. DISPLAY SECTION:

Inverted 400 Hz voltages are displayed in display section. Display section includes DIODE, OPTOCOPLER, ARDUINO and LCD display.

G. OPTOCOPLER 4N35:

Optocoupler is an electronic device that interconnects two separate electric circuits by means of light sensitive optical interface.

H. LCD DISPLAY:

16*2 LCD display is used to display the frequency of the inverted voltage.

III. SIMULATION

A simulation is a surmised impersonation of the activity of a procedure, the demonstration of simulating first requires a model is created. In this project the simulation is of inverter circuit and filter circuit and hardware is inverter circuit. The simulation is done in this project using the MATLAB software. This model represents that how to generate DC supply to 400Hz AC supply. MATLAB is a high-performance language for technical computing. It integrates computation,



visualization, and programming in an easy-to-use environment where problems and solutions are expressed in familiar mathematical notation.

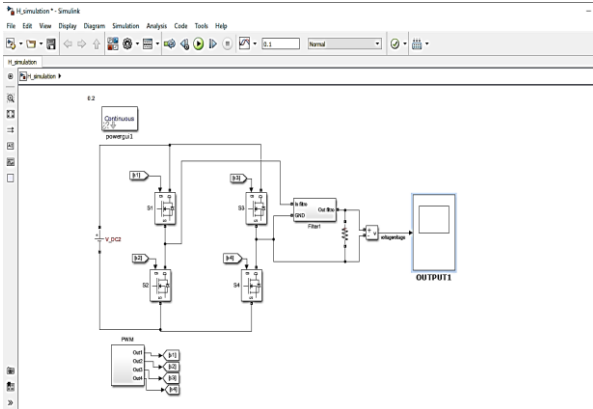

f. Simulink Model

Above simulation models shows the H-bridge inverter with filter connection. In simulation we are used PWM pulses. And filter is connected across the output voltage, so output voltages are sinusoidal in nature.

IV. SIMULATION OUTPUT:

By simulation output given below we can conclude that generated voltage is 400Hz.

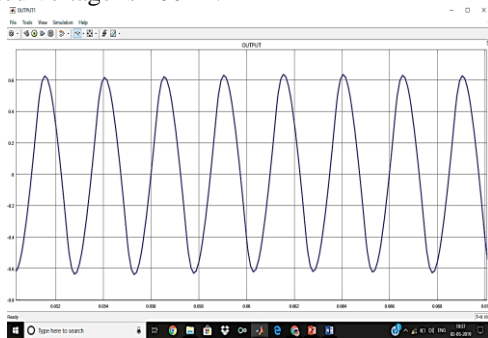

g. Simulink Output

V. HARDWARE MODEL:

Currently the hardware circuit setup is under progress. The validation of simulation results will be done in this stage.

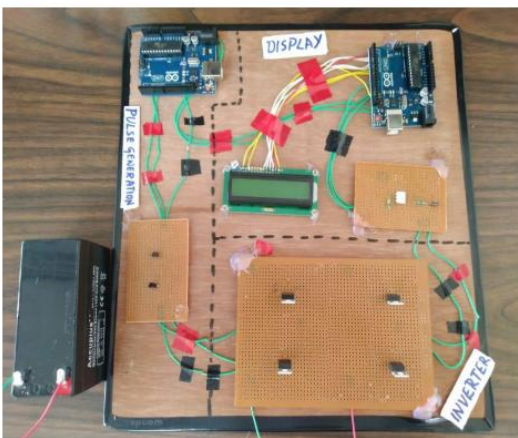

h. Hardware setup

VI. CONCLUSIONS:

The simulation result reveals that the output voltage frequency is 400Hz, which is ideal for aircraft applications.

Hence this design approach can be used in building inverter circuit for different needs of avionics industry. The validation of simulation result using hardware setup is currently under progress. The EMI and EMC compatibility testing can be made to test its compatibility against RF signals.

REFERENCES

1. Ahmad Rahal, "Design Of A Static Frequency Converter Suitable For Aircraft Power Systems", Aengus Murray Ph.D School of Electronic Engineering Dublin City University DECEMBER 1991.
2. Dmitriy Y. Komovskiy, "Comparative analysis of three-level PWM inverters for aircraft AC power systems", 17th International Conference of Young Specialists on Micro/Nanotechnologies and Electron Devices (EDM), Publisher:IEEE, Erlagol, Russia, 2016
3. Wenjing Zhang, Xiaobin Zhang, Wenjie Liu, Weilin Li, "Modeling and simulation of aviation static inverter based on dymola and modelica", IEEE International Conference on Aircraft Utility Systems (AUS), Publisher:IEEE, Beijing, China, 2016
4. Yanbo Che Guojian Liu ; Zhangang Yang ; Xiaokun Liu "Model of inverter in more electric aircraft based on generalized state space averaging approach", 6th International Conference on Power Electronics Systems and Applications (PESA), Publisher:IEEE, Hong Kong, China, 2015

AUTHORS PROFILE



Ozwin Dominic Dsouza obtained his B.E. from KVG college of Engineering, Sullia in the year 2005 from Electrical and Electronics Engineering department, M.Tech from NIE Mysore in 2010 in Industrial drives as his specialization . From 2010 to 2012 he worked as Senior Engineer at LG Electronics India Pvt. Ltd. in LCD/LED R&D division. From 2012 onwards he is working as Assistant Professor in the department of Electrical and Electronics Engineering at BMS Institute of Technology and Management. Currently he is pursuing PhD in the field of Pulsed Electric field.



Prajwal Shetty is currently pursuing his Bachelor in Engineering in Electrical and Electronics Engineering department at BMS Institute of Technology and Management Bengaluru.



Arjun S is currently pursuing his Bachelor in Engineering in Electrical and Electronics Engineering department at BMS Institute of Technology and Management Bengaluru.



Manjunath is currently pursuing his Bachelor in Engineering in Electrical and Electronics Engineering department at BMS Institute of Technology and Management Bengaluru.

