

# Cost-Effective Autonomous Garbage Collecting Robot System Using Iot And Sensor Fusion

A. Sengupta, V. Varma, M. Sai Kiran, A. Johari, Marimuthu R



**Abstract:** Waste collection and management is a subject undergoing extensive study, and solutions are being proposed meticulously. Thanks to an exponential rise in population, there is an increased production of waste, and also a significant amount of litter consisting of plastic, paper, and other such products carelessly thrown about and scattered in public. Thus, the need for a more robust waste management strategy is essential. Presently, waste management techniques either lack efficiency, or incur high costs. Several Governmental as well as Non-Governmental Organizations have made efforts to clean public spaces. Collection of the unorganized and scattered garbage is the preliminary and most vital step of waste management, following proper segregation and disposal. This paper proposes, explains, and implements an original concept of making a modular, scalable and cost effective system for garbage collection. Making an efficient use of Internet of Things to maintain a constant connection between a central server and a network of garbage processing and collecting, independent, autonomous robots, we rely upon such a system to produce accurate results, as well as considerably reduce the cost, hence providing a feasible solution to minimize human effort and costs during waste collection. It provides a gateway towards implementing garbage collecting robots in smart cities. Rather than describing the design of a single robot, we propose an entire system of robots interconnected in a network, to optimize time, energy and overall speed. There is always a trade-off between accuracy, efficiency and cost of garbage collection, especially when robots get into the picture. Our purpose is to find the perfect balance between these factors.

**Index Terms :** autonomous, image processing, IoT, garbage collector, low-cost, sensor fusion.

## I. INTRODUCTION

Garbage generation is an issue of worldwide importance, requiring global attention [1]. Improper management of waste and garbage is the root cause of several hindrances and issues that we face today such as health and hygiene, transport safety, wildlife endangerment and environmental aestheticism. At present, the method of cleaning up is majorly manual.

**Revised Manuscript Received on November 30, 2019.**

\* Correspondence Author

**A. Sengupta\***, Student at the School of Electrical Engineering, Vellore Institute of Technology, Vellore, Tamil Nadu- 632014, India.

**V. Varma**, Student at the School of Electrical Engineering, Vellore Institute of Technology, Vellore, Tamil Nadu- 632014, India.

**M Sai Kiran**, Student at the School of Electrical Engineering, Vellore Institute of Technology, Vellore, Tamil Nadu- 632014, India.

**A. Johari**, Student at the School of Electrical Engineering, Vellore Institute of Technology, Vellore, Tamil Nadu- 632014, India.

**Marimuthu R**, Associate Professor at the School of Electrical Engineering, Vellore Institute of Technology, Vellore, Tamil Nadu-632014, India.

© The Authors. Published by Blue Eyes Intelligence Engineering and Sciences Publication (BEIESP). This is an [open access](https://creativecommons.org/licenses/by-nc-nd/4.0/) article under the CC-BY-NC-ND license <http://creativecommons.org/licenses/by-nc-nd/4.0/>

With trends in industries shifting towards automation, it should also be efficiently applied towards waste management. While manual labor to clean up garbage is a good source of employment, there are several problems that are associated with cleaning up of garbage manually:

- Too much land pollution/garbage and inconvenient availability (unavailability) of sufficient workforce under all circumstances.
- Unavailability of manual labor in several remote areas (such as railway tracks)
- Safety concerns of humans in hostile work environments
- Lack of resources for hazard proof collection of nuclear waste

An autonomous garbage collection system may have a high manufacturing cost, but has negligible maintenance costs. Autonomous bots are a far better option when it comes to abolishing the monotony of tasks, overcoming safety issues during manual labor and reaching remote areas. In some cases, efficiency may also be better (1 robot can do the work of several men). The only drawback is that the production costs of the robots are high. Our aim is to substantially reduce the cost, so as to make the implementation on a large scale feasible, including implementation through government bodies.

Very little work has currently been done on making autonomous garbage collecting robots scalable. Existing work on garbage collecting robots has been limited to the following:

- Object detection using proximity sensor in front of robot  
Drawback: Does not differentiate between garbage and other objects
- Using expensive alternatives for waste collection and identification. They involve implementing heavy video processing algorithms requiring high end on-board GPUs to execute them.  
Drawback: These robots are extremely costly and impractical to use
- Generic robots in company R&D purposes for campus clean-ups  
Drawbacks: Cost is again very high and robots cannot access remote areas. These robots are also not scalable.

When it comes to application of autonomous robots in cleaning remotely accessible areas such as railway tracks, there is hardly any existing work. Certain prototypes have been developed that use suction for waste collection. This mechanism incurs high running cost and power consumption.

All existing work includes only ideas and prototypes, and there has been no actual product that has entered the market. The main reason for this is the lack of versatility and extremely high cost of the prototypes. Through our prototype, we aim to substantially reduce the cost and thereby open doors for scalable production of autonomous cleaning robots in the market.

Reason for failure of current prototypes in the market:

- Low cost prototypes which use proximity sensors can't distinguish between garbage and other objects. This gives rise to inaccurate results.
- Accurate robots which use computer vision and video processing use extremely high end processors for machine learning algorithms which causes the cost to shoot up.

We aim to bring the best of both worlds by providing accurate results without using high end processors and GPUs on-board. We shall accomplish the purpose using sensor fusion data from an ultrasonic sensor and image from camera, and use IoT to send data onto a central server for doing all processing. The method is explained in detail in the upcoming sections. The paper is organized into various sections as follows - The first section following this, reviews the existing pieces of work and literature proposed in this domain. The next section elaborates on the methodology that our system uses, depicts the algorithm and elucidates the various modules of the system. Following that, we explain the results and outcome of our work, including the novelty of our system. Lastly we summarize and conclude our findings.

## I. LITERATURE SURVEY

In order to understand the need for a compact, cost effective and scalable system, and before diving in to provide our own solution, we need to first understand the existing research and work done in the field. There have been numerous prototypes of garbage collection systems, autonomous robots, and waste segregators. In this section, we depict a concise review performed on these existing pieces of work, encompassing mobile robots, garbage collectors and IoT based systems for similar use cases. One paper proposed a Garbage collection Robot on the beach using wireless communications. The primary objective of this research was to clean up waste materials on coastline beaches. The mobile robot system consists of a shovel to scoop up waste, a trash box to deposit the waste gathered, a solar cell(which can help use an alternate source of power), an IP Camera to relay live feed to the user [18], and a Bluetooth module for wireless communication [19]. The controller used is a basic PIC Microcontroller, along with a LED Display. The UI and the robot controller are designed on Visual Basic. Motion is completely controlled by the user (not autonomous), with buttons being made for COM port connection, the four translational directions, as well as the vertical motion of the tray. It can pick up wastes big in size like plastic bottles, packets, etc. The robot is equipped with tank wheels, which make it suitable for use not only in the beach terrain, but also in other harsh environments. It is a manual, eco-friendly and cheap option. [1] Another paper presented a deep learning based approach to waste collection. The system consists of a 5- DoF manipulator, a

web camera, IMU, Odometer, GPS module, Ultrasonic rangefinder, and a garbage container. The terrains this application is suitable for are grounds, lawns and parks. The working is split into localization, navigation and perception. Localization deals with determining the position and orientation of the robot relative to a reference frame. A pre-generated map of the cleaning area is generated for localization and navigation. The navigation module is for path planning and obstacle avoiding. Using the pre-fed environment map, the robot must find an optimal, obstacle avoiding path to pick up all the garbage lying around within the confines of the local map. Perception deals with garbage classification and localization. Image recognition includes ground segmentation, contour extraction, object tracking, and then classification. The neural network used here is CNN. Once identified, the robot will translate such that the image is kept in one particular part of the image continually, and the arm will then take over and pick up the object at a certain distance if it is classified as waste. Robot moves under PID algorithm. If out of range, tries to come back in range. Good accuracy obtained, most for bottles (91.87%), least for waste papers (77.7%). [2] A paper proposed a robot based indoor autonomous trash detection algorithm using Ultrasonic Sensors. The idea here was to eliminate the heavy image processing algorithms for waste classification. The object shape has been scanned by 2 horizontally moving ultrasonic sensors placed one on top of the other. The ultrasonic sensors map the dimension of the object by being mounted on a servo base which rotates horizontally. The upper ultrasonic sensor confirms the object size and decides whether it is a waste or not. It then moves towards the trash and picks it up using an arm. The robot also comes equipped with a trash bin. It differentiates between walls/furniture and trash based on object width as scanned by the lower ultrasonic sensor. Here, waste classification simply based on width and height of object. Cheap option, complexity saved, but accuracy compromised. [3] Work has also been done in creating a house cleaning robot system using path indication and position estimation using a ceiling camera. The idea presented here is that the user should be allowed to select which zone he wants cleaned. The user selects that on his computer screen from an image taken by a web camera attached to the ceiling of the room. When he clicks the zone he wants cleaned, the points clicked on the image have to be manually mapped to coordinates in the room, and this movement coordinate data is fed as an instruction to the robot. To detect the position, a LED mounted on the robot is tracked by the camera. The desired application area here is homes, and other cramped places where sensor data might not be completely reliable. Odometer errors are neutralized by camera pre-determined optimal path calculations. This concept saves a lot of time, but isn't completely automated, and requires some degree of human intervention. This method is tough to implement when robot goes out of camera frame. [4] Another paper demonstrates the use of a different algorithm. The robot (Khepra robot with 2 wheels and a gripper) was first trained in simulation to learn what it must do using the evolutionary process, and then the final generation was deployed onto the hardware board. Each task of the robot (for example identifying waste, picking up waste, dumping waste, etc.) was assigned a fitness level or score.

The algorithm parameters adjusted themselves to maximise the score as the generations (iterations) progressed. Sensor readings (8 IRs) were used to take inputs from the environment and study the interactions of the robot. These sensor inputs were connected to a selector layer, which short-lists the inputs with the best fitness levels. These are then fed to the motors to perform actuation accordingly. During simulation, as the number of generations increased, the number of crashes drastically came down, and the number of pick-ups and releases increased. In the real environment, a decrease in performance was observed. The best accuracy achieved was 93% and that occurred once. Artificial evolution stabilizes after a few hundred generations, and then nothing new happens. Here, the arena had to be pre-mapped and simulated several times before desirable results were achieved. To do this for every different arena is a painstaking task. Also, the accuracy obtained was very low, and even though the robot adapted to what its desired function was within time, it never gave consistently good results. [5] A separate robot uses a shaft with rotating blades to scoop up waste, which is a very good and effective scooping mechanism. Arduino Uno is used and interfaced with Ultrasonic sensor to detect waste obstacle. Hence, this mechanism will scoop up anything it sees within a distance, and empty it in a bin mounted on it. The bin thrash level is continuously monitored. If the bin is full, it will go to the fixed dust bin, and by tilting, empty the mobile bin. [6]

Another approach includes powering up the bot by the Intel Galileo board instead of a Raspberry Pi. The Intel Galileo board is preferred since the Raspberry Pi is less efficient in the number of instructions it executes per clock cycle. In this system, IR sensors are used instead of Ultrasonic sensors. An infrared Sensor has two IR LEDs. One is the IR Transmitter and the other one is IR Receiver. The communication between the transmitter and receiver mimics the work done by an ultrasonic sensor. There is one Bin attached to the Driving Base which will have one servo Motor so that it can automatically open when it reaches the slot and close it after taking the garbage. There is one more IR Sensor placed on the Bin so that it can detect whether the Bin can take in more Garbage or not. The servo motor is further interfaced with the Galileo board. [7] The easiest approach towards a student-developed autonomous garbage collector bot is to center it on a Raspberry Pi. Conventionally, the system consists of four geared motors of 10rpm each, motor drivers and an ultrasonic sensor. The ultrasonic sensor acts as an input to the Raspberry Pi. The motors are connected to the output of the Raspberry Pi through the drivers. The ultrasonic sensors detect the obstacles and the motors are made to rotate based on the pre-programmed instructions in Raspberry Pi. Principles of image processing are then deployed to help the bot identify garbage. The image processing algorithm used here simply identifies the object as an animal or not. And if it not an animal, it picks up the object, whatever it may be. Thus the accuracy of waste scooping will be very low.[8] Another prototype featured a robot based on the iRobot Create and it used an onboard computer as well as a Freescale DP512 Microcontroller. The onboard computer runs the main program and communicates with the DP512, the Create base, and a webcam. The robotic arm uses five servos to act

as joints in the arm, one servo for the gripper, and one short range IR sensor to confirm the successful pickup of an object. The navigation component also uses a servo for camera direction control and two IR sensors, one far-ranged and one close-ranged, to detect the distance of obstacles. For the software, the arms control used trajectory planning based on forcing the arm to assume a certain general configuration. The joints in the arm were moved in a predetermined order to prevent collisions and also featured provisions for smooth movement. The navigation used camera data to generate a virtual map and applied the D\* search algorithm to find a path. The image processing uses a combination of the SURF algorithm for precise object detection and a color filter for sensing the presence of general objects. This model proved to be impractical as the servos in the robotic arm turned out to be weak while lifting the garbage. [9] Prototypes functioning wirelessly have also been developed. The robot is powered by a solar panel. The user can control a robot via a program developed from web application. The commands from the user are sent via the Wi-Fi router to ESP8266 for processing. The components used are: Arduino UNO and LCD, Wireless Wi-Fi, ESP8266 module, and Ultrasonic Sensor, Dc Motor, Servo Motor. The Wireless Wi-Fi ESP8266 module is used for adding Wi-Fi functionality to an existing microcontroller via a UART serial connection. The other parts serve a similar purpose to that of a conventional autonomous garbage collector bot. The robot was never really tested on real ground, everything was performed only on Proteus simulations. Thus, no real-world conditions or challenges were even attempted, and thus it is may not be reliable for one who wants to test. [10] Another paper proposes, what they call, the Robodumpster-Autonomous garbage collector. The robot has a 7 DoF arm that can be wirelessly controlled. It can be programmed using various programming languages. Infra-red sensor used to measure width of object and accordingly decides whether it is waste or not. The arm scoops up the waste empties it in a waste bin. There is no accuracy in waste classification here since the only parameter used is width of the object. This 7DoF arm is manually fabricated and therefore, this is an expensive technology, not cost effective. [11] Another paper proposes waste collection automation in 2 parts. The fixed garbage part has a RF module and ultrasonic sensor module which notifies the garbage collecting car when the bin is full. When the garbage car receives the signal from the RF module, it moves to the dust bin, scoops the waste and goes back. This paper does not consider urban environments, people, traffic, etc. Also, coordination between bin and car while scooping waste is not clear. This product might not be feasible commercially. [12] Dustcart is a 2 wheeled mobile robot based on Segway RMP200 platform that traverses door-to-door in difficult terrain. It operates on user calls and works on Ambient Intelligence system which sends way points to robot and controls each robot through the cloud. A supervisor manages all operations of the robot. Ambient Intelligence maintains a geo-referenced map of the city. Dijkstra used to calculate shortest path to destination, relevant map provided.



Encoders, Compass, and Lidar are used for localization since GPS might provide inaccuracies. Beacons attached at certain points to redirect the robot and update its readings. Very good precision was achieved and not much error was observed. Reliability/safety needs to be addressed if used commercially. The technology used was very expensive [13]. Another autonomous trash collector uses ultrasonic and infra-red sensors are used for obstacle avoidance and waste detection. Arduino Atemga 2560 is used. Here a wall following S-shaped path is followed. Vacuum suction is used to pick up waste. A lot of power is required for vacuum suction. Also anything is classified as waste, there is no classifier. This algorithm will not work in complex environments, works in free space. [14]

An alternative prototype proposed uses Arduino Uno, Ultrasonic sensors (HCSR04), Pick and place arm in the form of a tray to scoop up and empty waste in a mobile dustbin on its back. There is no classification of waste and non-waste classification. [15] Another piece of work, also termed as Robo-Dumpster is a mobile robot that searches for full garbage cans, empties them into its on-board bin and dumps this garbage into the designated local bin when its receptacle is full. It makes use of a CMU camera to seek garbage cans that are full, collects the contents and deposits it to the designated area, which it identifies using its CMU camera. It made use of the Pridgen Vermeer Robotics Xmedga128 microcontroller board. This robot also uses 2 IR sensors to avoid obstacles while embarking upon its trajectory to scan for obstacles. [16] G S Kanna et al presented a different approach [17] is using MATLAB as an image classifier and segregating biodegradable and non-biodegradable waste using K-means clustering algorithm, a camera and a PIC controller (16F877A). However, presently MATLAB cannot perform real-time image processing; hence such an implementation will not optimize time.

## II. METHODOLOGY

### A. Algorithm Flow

We have combined the usage of proximity sensors with computer vision to accomplish our purpose. The camera, mounted on the chassis of the robot, remains inactive until an object is detected by the proximity sensor. When an object is detected, the camera captures a single image and sends it to the server for image processing classification to detect it as garbage or non-garbage. The advantage of this method is that a lot of time, memory and power is saved by performing processing on a single image, rather than continuously performing processing on every frame of a live video feed. Thus we can solve this purpose by using low-end processors and hence the hardware cost shall be substantially reduced. For classification of the image, we can use two approaches: A. Perform image processing on the robot processor itself: This will require a moderate cost processor to be on the body of the robot. There may be some lag in output since processor won't be as high end. But because of the same reason, the cost will be less. B. Send images from multiple robots on a central server: The central server will use a high end processor while the robot processors can be extremely low end. The robots will simply capture images and send them wirelessly to the server. Image processing will be done on the server

itself (which will give extremely rapid results) and the output will be sent back to the robot. The robot shall then decide whether to pick the object or not. We have implemented the latter in our system.

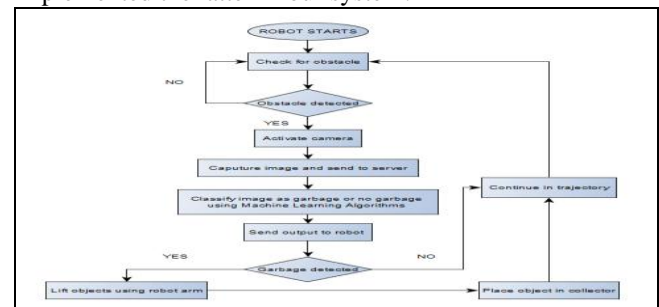

Fig-1: System Flow

Installing the server with a high end processor will incur an extra cost. But this is compensated by the fact that the processors used in individual robots will be far less costly, and the fact that result of classification will be much faster. If the object is classified as a waste, the robot will move towards the object. When the object is reached, the robot tray, mounted on the chassis itself shall pick the object up for disposal. If the image is classified as non-garbage, then the robot shall avoid the obstacle, and move in its own trajectory.

### B. System Design

#### 1. Robot Body Architecture

The robot is made on a flat chassis, with four wheel drive. At the front, a custom garbage collection tray is mounted, responsible for picking up the garbage, when detected. The flat chassis is made of a sturdy aluminum sheet of measured dimensions, attached to a narrow, ready-made DIY robot chassis. Four wheels are attached to it via four different DC motors. The tray is mounted with the help of 2 servo motors, on either extremes of the width of the robot. On top of the aluminum sheet, contains the main ECU of the robot, with all circuitry and connections.

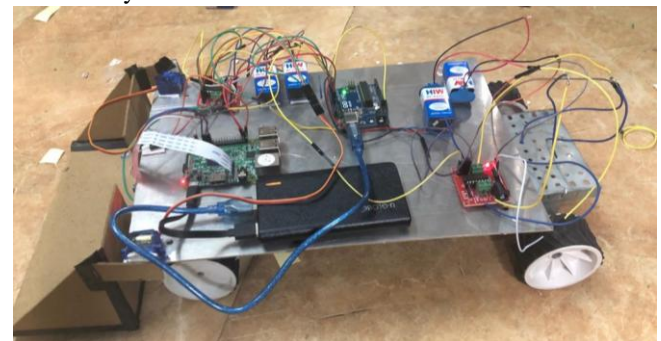
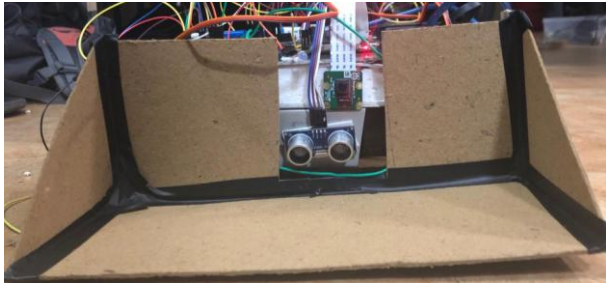

Fig-2: Robot Design

The tray contains a small slot, making space for the presence of an ultrasonic sensor and Pi-Camera. This Depth of the slot is such that, the tray may move up and down freely, on the command of the servo motors, without being obstructed by the protruding Ultrasonic sensor and Pi-camera.



**Fig-3: Robot front**

**2. Robot circuitry architecture**

The ECU of the Robot is controlled mainly by a Raspberry-Pi 3B (hereon referred to as Rpi), with an Arduino UNO aiding its functionalities.

- The Rpi is connected to the ultrasonic sensor, L293D motor driver modules (2 in Number), Pi-Cam, and the Arduino.
- The motor driver modules are each connected to 2 DC motors, which drive the wheels
- The Arduino UNO is connected to 2 servo motors which control the movement of the tray.

The entire circuitry is shown in Fig-3

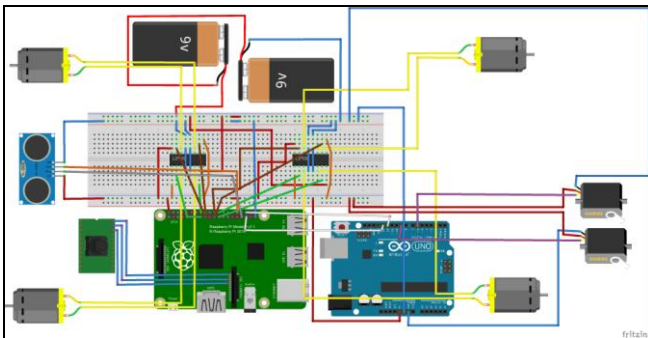

**Fig-4: Fritzing Schematic of the ECU, along with peripherals, connected in circuit.**

**3. Network Architecture**

Our system comprises of not only one robot, but many such robots. All of these are connected to a central server. We have implemented this server through a laptop computer. The laptops, along with the RPIs of each and every robot, are all connected to one common WiFi hotspot. A connection is hence established among all of these. If online classification services are to be used, such as tensorflow, then the server needs to be connected to the internet. This is explained in detail, in forthcoming sections.

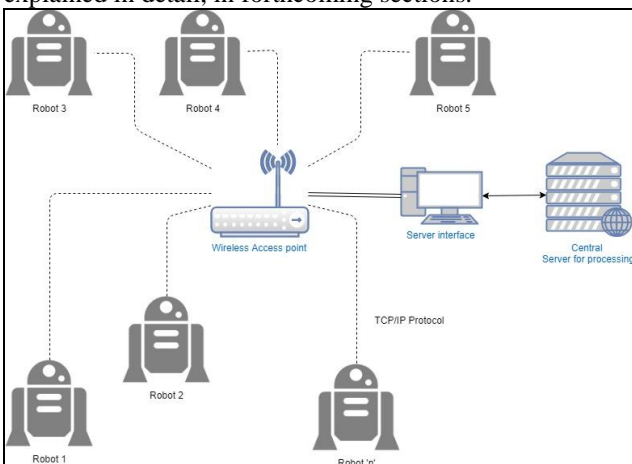

**Fig-5: Network architecture of entire system**

**C. Modular Analysis**

The system is divided into a number of Modules. We shall analyze each of these modules in detail, as follows:

**1. Trajectory and motion module**

The robot moves in a pre-programmed trajectory, covering its locality or zone which it is responsible for cleaning. The trajectory program is present on the Rpi. The Rpi sends commands to the motor drivers, which in turn controls the motors for various functionalities, such as forward, reverse, left turn, right turn and stop. In an obstacle free path, the robot continues to move forward. The trajectory may further be optimized by taking into account a number of factors so as to cover minimum distance while accomplishing its purpose. After the obstacle is detected, depending on whether it is garbage or non-garbage, it will take action. If non-garbage, then the robot will continue in its trajectory after avoiding the obstacle, by making a suitable left or right turn.

If the garbage is detected, then the robot, after picking up the piece of garbage, must travel to the dustbin of the assigned zone, and deposit it.

**2. Object Detection module**

This is done by the classic method of using an ultrasonic sensor. If an object is at a distance of 20cm or less from the ultrasonic sensor, the robot stops moving, the object detection flag is set as high, and the image capturing module is activated.

**3. Image Capturing Module**

Once an obstacle is detected, the Pi-Cam captures a single image, at the instant the flag is set high, and sends the image to the server through the communication module. After this, it waits for response from the server.

**4. Classification Module**

The server performs classification techniques on the image that it receives. The algorithms to be used can be as high end as possible, since the central server uses high-end hardware. Hence the algorithm used should be performed by keeping accuracy in mind.

For demonstration purposes, we have used Fast Approximation Nearest Neighbor search algorithm. The algorithm works on the principle of feature matching between the training images and the input images. It extracts the major features such as high contrast pixels from the training images and tries to match those with the input image. Fast Approximation Nearest Neighbor algorithm requires minimal processing power and gives fairly accurate results.

Other algorithms used may include Haarcascade image classifier for garbage, YOLO object detection using tensorflow API etc.

**5. Communication Module**

We have used TCP/IP communication protocol for communication between each robot and central server.

It is a Client-Server communication based model, with the Robot RPi being the Client, and central server being, as the name suggests, the Server.



## Cost-Effective Autonomous Garbage Collecting Robot System Using Iot And Sensor Fusion

Since the entire RPi code is in python, we have used python's socket programming API for the communication. The image is captured by the Pi-cam and sent to the server. The server performs classification while the client waits for response. After classification is complete, the server sends the result back to the client using python socket.

It must be noted that all nodes (robots + computer) must be connected to the same WiFi hotspot. If the Server gets disconnected, then communication will not be possible and the system will fail.

However, if any one robot (Client) gets disconnected from the network, the remaining robots will function as usual without any negative effect. This modular approach enables easy identification of locating the network fault.

### 6. Actuation Module

Depending on the response received from the server, the system actuates. If garbage is detected, the robot will move closer to the object, and lift up the garbage. The way this happens is that the raspberry pi, on receiving a positive signal, sets the actuation flag as high. This results in the robot moving a certain distance forward, and the command getting passed on to the Arduino. The Arduino then controls the servo motors, which is responsible for moving the tray, hence lifting the object up.

### 7. Waste Management Module

The current robot, enables a particular piece of garbage to be picked up, and being deposited at a dustbin in nearby proximity, of known coordinates. The problem with this is that, the robot unnecessarily has to make several trips to the dustbin. To overcome this issue, we may include an on-board bin, and replace the tray with a robotic arm. This will allow for the robot to pick up many garbage pieces at once, until the bin gets full, without having to visit the local bin so many times. Once the waste is placed in the on-board bin, the robot will again scout the area for more waste. This process will be repeated until the bin is full, the bin level being constantly monitored by an ultrasonic sensor. Contents must also be deposited from the on-board bin, to the larger local bin after waste is collected.

## III. RESULTS AND DISCUSSION

The motion, object detection, image capturing, data communication and actuation were all performed successfully.



Fig-6: Image on client side

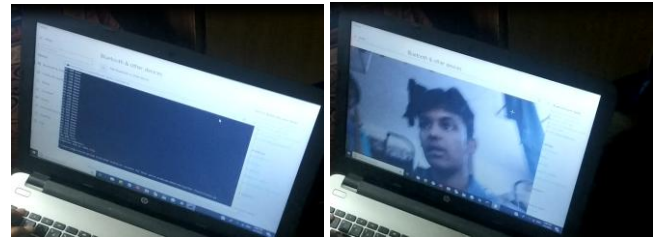

Fig-7: Image being transferred to server (laptop) and being displayed

Shown in Fig-6 and Fig-7 are the successful image capturing and transfer of image from client to server. The python scripts for the communication procedure are also depicted in Fig-8 and Fig-9.

The server script must contain the IP addresses of each and every client, that is, of all Rpis on the network. The given code is just for communication between a single Robot and Raspberry Pi.

The demonstration of garbage classification is also shown. A waste water bottle is classified as garbage and a green outline is drawn over the concerned object.

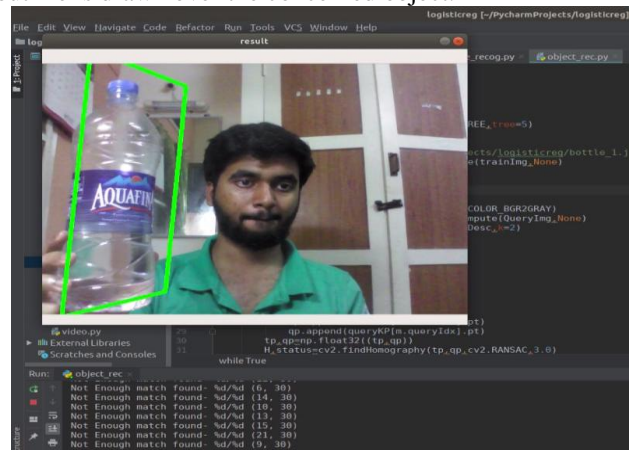

Fig-8: Garbage classification of waste

We attached an LED to the front of the robot to indicate the detection of garbage. It was found that, whenever garbage was detected, the LED began to glow, and the tray was smoothly lifted up and down by the servo motors.

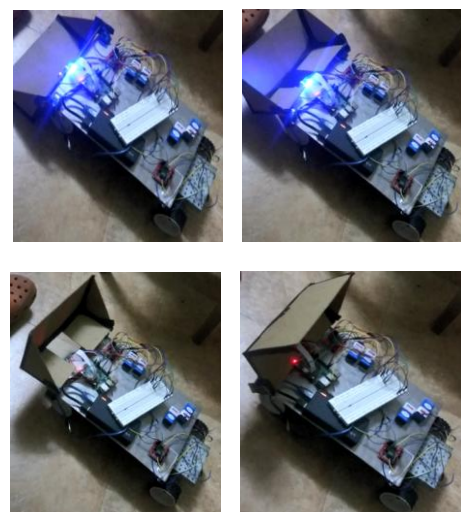

Fig-12: Actuation of tray in progress

Table- I: Summary of proposed prototype with respect to other technologies

Paper Ref. No.	De-merit of technique	Issue Solved By our prototype
[3]	Accuracy compromised to reduce cost	Yes
[4]	Only in-door, within range use cases and lack of portability	Yes
[2],[5]	Region of interest must be pre-mapped prior to deployment	Yes
[8],[15]	Low accuracy	Dependent on algorithm deployed on server
[10]	Only simulated model exists without real world deployment	Yes
[13]	High cost	Yes
[17]	Lack of real-time capabilities	Yes

#### IV. CONCLUSION AND FUTURE SCOPE

Hence the proposed prototype has successfully been implemented. The novelty of this paper lies in the concept of a cost-effective system that uses IoT to optimize the working of a network of garbage collectors. Furthermore, the adoption and optimization of the best features from existing technologies, into a single integrated system makes it very efficient. The deployment of OpenCV in a real-time environment for image processing and classification, makes the module dynamic in contrast to MATLAB based classifiers which is widely used, and lacks real-time processing capabilities. Also, to optimize time, speed and memory, the images are sent to a central server for processing, rather than using the on-board processor, since the on-board processor has limited processing speed and capabilities. The third novelty of this paper is that the processing is done on a central server, which can handle several tasks at a time, and thus a swarm of garbage collecting robots can be deployed simultaneously. Thus, while optimizing cost, there is also no compromise in the quality and functionality of the robot, hence rendering it an optimal prototype for garbage collecting applications. This approach can be used to simultaneously deploy multiple robots in different areas. The system is cost-effective and time optimal. The image processing algorithm could be improved upon without any constraint in processing hardware, since that would be used only in the central server. The system may also encompass a broad domain of use-cases. It can particularly be used for nuclear-waste collection, where human presence is unsafe. It is primarily proposed for a "smart city". Apart from this, it also may be implemented in moon and planet rovers, for discovery and surveillance purposes. Our system, if implemented properly can be scaled up successfully.

#### REFERENCES

1. S. Watanasophon, and S. Ouitrakul, "Garbage Collection Robot on the Beach using Wireless Communications" In Proc. 3rd International Conference on Informatics, Environment, Energy and Applications IPCBEE, vol.66 (2014).
2. J. Bai, S. Lian, Member, IEEE, Z. Liu, K. Wang, D. Liu, "Deep Learning Based Robot for Picking up Garbage on the Grass Automatically" In Proc. IEEE Transaction on Consumer Electronics TCE.2018.2859629.
3. S. Kulkarni, S. Junghare, "Robot Based Indoor Autonomous Trash Detection Algorithm using Ultrasonic Sensors", presented at 2013 International Conference on Control, Automation, Robotics and Embedded Systems(CARE).
4. T. Takeshita, T. Tomizawa, "A house Cleaning Robot System - path indication and Position estimation using ceiling camera" presented at

- SICE-ICASE International Joint Conference2006 in Bexco, Busan, Korea.
5. S. Nolfi, "Evolving non-Trivial Behaviors on Real Robots: a garbage collecting robot" , Institute of Psychology, National Research Council, Rome, Italy. Technical Report 96-04, March 1996.
6. S. Apoorva, Chaithanya, R. S. Prabhu, S.B. Shetty, D. D'Souza, "Autonomous Garbage Collector Robot", presented at International Journal of Internet of Things 2017, 6(2): 40-42.
7. Technomentis, "Automated Garbage Collector", instructables.com.[Online].Available: <https://www.instructables.com/id/Automated-Garbage-Collector/> [Accessed April 10, 2019].
8. S. Khandare, S. Badak, Y. Sawant, S. Solkar, "Object Detection Based Garbage Collection Robot", International Research Journal of Engineering and Technology (IRJET), Volume 05, Issue 03. March 2018.
9. Y. Kim, J. Jefferson, Dr. A. Bovik, R. Chen, S. Chu, B. Nguyen, K. Tan, "Automated Garbage Collecting Robot", EEE464 Senior Design Project, Electrical and Computer Engineering Department, University of Texas at Austin, Spring 2017.
10. K. Kamal, S. Mukesh, S. S. Ganesh Kumar, M. Sudhakaran, "Design of Garbage Collection Robot using Wireless Technology", International Research Journal in Advanced Engineering and Technology, Vol 3, Issue 2(2017), pp. 1901-1911.
11. Rama Prabha D, S. Mahindru, A. Srivastava, P. Nilalohita, "Autonomous Garbage Collector-Robodumpster", International Journal of Civil Engineering and Technology(IJCIET), Volume 9, Issue 12(December 2018), pp. 545-552
12. S. Parashar, P. Tomar, "Waste Management by a robot- A Smart and Autonomous Technique", IOSR Journal of Electronics and Communication Engineering(IOSR-JECE), Volume 13, Issue 3, Ver. 2(May-June 2018), pp. 31-36
13. G. Ferri, A. Manzi, P. Salvini, B. Mazolai, C. Laschi, P. Dario, "DustCart, an autonomous robot for door-to-door garbage collection:from DustBot project to the experimentation in the small town of Peccioli", presented at the 2011 IEEE International Conference on Robotics and Automation, May 2011, Shanghai, China .
14. G. Sivasankar, B. Durgalakshmi, K. Seyatha, "Autonomous Trash Collecting Robot", International Journal of Engineering Research and Technology(IJERT), Volume 6, Issue 04, April 2017.
15. K. Satish, "Autonomous Plastic Trash Disposal Drone- The Trash-Bot",instructables.com,[Online]. Available:<https://www.instructables.com/id/AUTONOMOUSPLASTICTRASH-DISPOSALDRONE-THE-TRASH-B/> [Accessed April 15, 2019].
16. A. Hamlet, Arroyo, Schwartz , "Robo-Dumpster: The Autonomous Garbage Truck", EEL5666, Intelligent Machine Design Lab, University of Florida
17. G S Kanna, S S Kumar, R Ragavan, M Balakrishnan, "Automatic Garbage Separation Robot Using Image Processing Technique", International Journal of Scientific and Research Publications, Vol 6, Issue 4(2016).
18. Gupta, R.K., Balamurugan, S., Aroul, K., Marimuthu, R, "IoT based door entry system," Indian Journal of Science and Technology, 9(37), pp. 1-5
19. Singh, A.K., Balamurugan, S., Aroul, K., Marimuthu, R, "Design of universal module for personal security," Indian Journal of Science and Technology, 9(30),99031.

#### AUTHOR PROFILES



**A. Sengupta** was born in Chennai on June 21, 1998. He is currently a 4<sup>th</sup> year student pursuing Bachelors of Technology in Electrical and Electronics Engineering, with a Minor's degree in Computer Science and Engineering from Vellore Institute of Technology, Vellore, India. He specializes in embedded systems,

computer vision and has developed numerous projects pertinent to embedded applications in robotics as well as healthcare. He has received funding grants for his startup ventures for development of low cost assistive devices for disabilities. He is currently the President of VIT-Vellore's Electronics club and has taken technical lead on several projects. He has worked on embedded systems development at Hindustan Aeronautics Limited as well as L&T Technology services. His area of interest includes Cyber Physical Systems and Robotics.

# Cost-Effective Autonomous Garbage Collecting Robot System Using Iot And Sensor Fusion



**V. Varma** was born in Mumbai on June 27, 1998. He is currently a 4<sup>th</sup> year student pursuing Bachelors of Technology in Electronics and Instrumentation Engineering from Vellore Institute of Technology, Vellore, India. He has worked on several projects in electronics as well as robotic simulations, and his aim after the completion of his Bachelor's degree is to pursue a Masters of Science degree in Robotics and Automation

abroad. He has worked in Embedded Systems at Hindustan Aeronautics Limited and has also worked at Bharati Robotic Systems in Pune, India where he programmed and implemented autonomous navigation and control algorithms. His area of interest is manipulators, mobile robotics, control systems, and humanoid robotics.



**M Sai Kiran** was born in Hyderabad on June 25, 1998. He is currently a 4<sup>th</sup> year student pursuing Bachelors of Technology in Electronics and Instrumentation Engineering from Vellore Institute of Technology, Vellore, India. He will be working as a Market Analyst for Axxela Advisory Services LLP, Mumbai from

January 2020 onwards. He has been part of a project team funded by ISRO aimed at building a payload to detect meteorite dust particles near the equator. He has worked with start-ups such as SelectDine and VEMA Solar and helped streamline their processes and organisational structures. His areas of interest are Business Analytics, Trading, and Techno- Business Integration.



**Aashray Johari** was born in Vadodra on September 12, 1998. He is currently a 4<sup>th</sup> year student pursuing Bachelors of Technology in Electronics and Instrumentation from Vellore Institute of Technology, Vellore, India. He will be

working as a Management Consultant for KPMG, India from January 2020 onwards. He has worked with VIT Incubatee Start-up Cam Cann Smart System Tech Pvt. Ltd. as their finance and legal head. He also won the Smart India Hackathon in March of 2019. He was also a part of the Technology And Gaming Club of VIT. His areas of interest are Control Systems, Automation, Consulting and Business Analytics.



**Marimuthu R** received his Bachelor degree in Electronics and Instrumentation from Bharathiyar University, India. He received a Masters in Engineering degree in Applied Electronics from Anna University, India. He completed Ph.D. degree from Vellore Institute of Technology, Vellore, India. He is currently an Associate Professor at Vellore Institute of Technology, Vellore. His areas of interest and research include Computer

Architecture and Embedded Systems at Vellore Institute of Technology. He has more than 15 years of teaching experience and has over thirty research papers to his name. His current research area is automation, renewable energy, electric vehicle and low power and high speed VLSI architectures.