

Fuzzy Based Fault Classifier and Time Domain Reflectometry Based Fault Locator for Underground Cables

Bavithra K, Latha R, Madhugogul P, Devaprasath R

Abstract— Cables are insulating wires used for transferring power or transmitting signals. If any fault occurs in the cable then, it causes detrimental effects to power system equipments. The technical difficulty is to find, analyze, and classify faults. In case of underground cables it will be a time consuming and expensive process to repair the faults or replace the cables. This paper aims to analyse the faults by creating the various types of short and open circuit faults, classify them by taking in account of grounding, and to locate the distance at which the fault is occurred. The underground cable is simulated using MATLAB/Simulink, the faults are created and the Fourier transform of voltage and current are observed at the source end. The generated fault phase current data from the simulation has been normalized using fault index is the input to the Mamdani fuzzy logic controller. The defuzzified output is verified for different phase current values which classify the nature of the fault. Two fuzzy classifiers like ground and phase faults are developed which holds good for different range of cables. A methodology to find the fault location in long transmission line is attempted using PSPICE, by creating short circuit fault. The distance is determined by using velocity of propagation of travelling waves, which is realized using impulse voltage wave generator which is based on impedance

Keywords— Fuzzy Logic Controller, PSpice, Time Domain Reflectometry.

I. INTRODUCTION

Microelectronics associates with fabrication of Cable is a wire like material which is used for connecting more devices. It is used for transmitting signal, electrical power. Cables are used for wide range of purposes, and each must be tailored for that purpose. It consists of more number of optical fibres in which they use total internal reflection as a principal. When fault occurs in underground cables, it is very difficult, time consuming, and expensive process to locate, repair (or) replace the cable. But in the present scenario, the fault location is easily carried out using various methodologies, tools and devices.

Fonseca Badilo et al. (2012) have modeled distributed parameter line as an underground cable. In this model, all types of faults such as LG, LL, LLG and LLL have been studied and their waveforms are observed. The wavelet based fault current analysis is carried out by Zhao et al. (2000), Jiantao Sun et al. (2007), Magdy B. Eteiba et al. (2014). The Fourier analyzed fault voltages and current values are obtained from the simulink model and the values are fed to the training set of artificial neural network by Mamta Patel et al. (2012) and Kunal Hasija et al. (2014). Transient energies of details information for the two consecutive data at the fault are used for analysis and neural networks are designed to classify and locate the fault at different single line to ground fault conditions by M. Gowrishankar et al. (2016). The fault current observed is given as the input for the fuzzy logic and the type of fault is determined by using fuzzy classifier by Avagaddi Prasad et al. (2015), Sekharmanthri Jyothsna et al. (2017). The Orcad model deals with location of fault in underground cable network. For precision, a three stepped process is followed in Pspice simulation as referred in the book Analog-Design-and-Simulation-using-OrCAD-Capture-and-PSpice-Dennis Fitzpatrick (edition 2012). Company. A. Ngapitakkul et al. (2010) proposed that the fault location identified by analysing the first peak time, which is obtained from the faulty point occurred in the cable.

Thus, Cable faults can be analyzed using Fourier methodology and normalized using fault index calculations. This is fed as input to Mamdani based fuzzy logic controller, where the rule base are developed employing knowledge base. The faults are classified as ground and phase faults by two fuzzy classifiers. The prototype of fault detector is realized in proteus and modeled using different impedances and its corresponding voltage drops. The TDR principle is employed to detect the fault location using velocity of propagation using PSPICE.

II. PROBLEM FORMULATION

The Fig 1. Shows the simulation in MATLAB. Here, three phase voltage source are given to the distributing parameter (cable). The fault is created using the three phase fault block. The voltage and current values is measured in VI measurement block. Then the data required for computing and the graph is obtained by using scopeblock.

Revised Manuscript Received on November 08, 2019.

Bavithra K, Assistant Professor, Department of Electrical and Electronics Engineering, PSG Institute of Technology and Applied Research, Coimbatore 641062, India (e-mail: bavithra@psgitech.ac.in)

Latha R, Associate Professor, Department of Electrical and Electronics Engineering, PSG college of Technology, Coimbatore 641004, India (e-mail: lathasivak7@gmail.com)

Madhugogul P and Devaprasath R, UG Scholar, Department of Electrical and Electronics Engineering, PSG Institute of Technology and Applied Research, Coimbatore 641062, India (e-mail: mvsanthm16@gmail.com)

Fuzzy Based Fault Classifier and Time Domain Reflectometry Based Fault Locator for Underground Cables

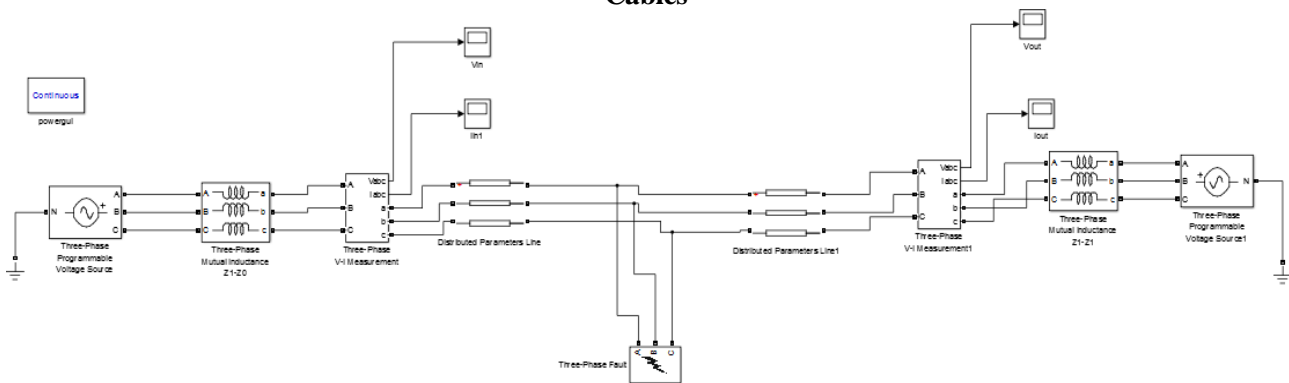

Fig.1. Block diagram of MATLAB simulation

A. Fault analysis and normalisation

In this work, the normalization technique is to be carried out before applying it to the fuzzy logic controller as an input. The inputs S1, S2, S3 are obtained by the equations. The value of P1, P2 and P3 are calculated by using equations 2.1 to 2.9:

$$P_1 = \frac{\max\{\text{abs}(I_a)\}}{\max\{\text{abs}(I_b)\}}$$

$$P_2 = \frac{\max\{\text{abs}(I_b)\}}{\max\{\text{abs}(I_c)\}}$$

$$P_3 = \frac{\max\{\text{abs}(I_c)\}}{\max\{\text{abs}(I_a)\}}$$

.... (1)
.... (2)
.... (3)

The value of S1, S2 and S3 are given to the input for fuzzy classifiers for classification of type of faults occurred in the system.

Fuzzy logic controller

Fuzzy logic is a fascinating area of research because it does a good job of trading off between significance and precision. The block diagram of fuzzy logic tool-box is shown in Fig. 2. ORCAD

It is used for analyzing the fault location using PSpice. The circuit diagram of PSpice simulation is given Fig 3.

$$D = \frac{V_2}{2} \dots (10)$$

.... (2)
.... (3)

The values of the parameters for the cable as shown in the Fig. 3. are given as,

Length of cable = 10 km R= 25 Ω/km

L= 334 μH/km

C= 1.05 μF/km

Amplitude of voltage pulse= 1V Rise time = 10 ns

Fall time = 10 ns Delay time = 100 ns Pulse width = 100 ns

Velocity of wave is given by equation

$$V = \frac{1}{\sqrt{LC}} \dots (11)$$

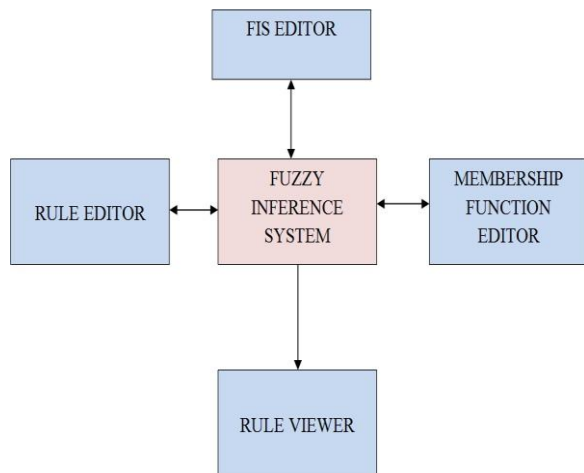

Fig.2. Block diagram of fuzzy logic tool-box

The value F1, F2 and F3 are calculated by using the value of P1, P2 and P3

$$F_1 = \frac{P1}{\max(P1, P2, P3)} \dots (4)$$

$$F_2 = \frac{P2}{\max(P1, P2, P3)} \dots (5)$$

$$F_3 = \frac{P3}{\max(P1, P2, P3)} \dots (6)$$

Lastly, the differences of these F1, F2 and F3 are calculated as follows:

$$S_1 = F_1 - F_2 \dots (7)$$

$$S_2 = F_2 - F_3 \dots (8)$$

$$S_3 = F_3 - F_1 \dots (9)$$

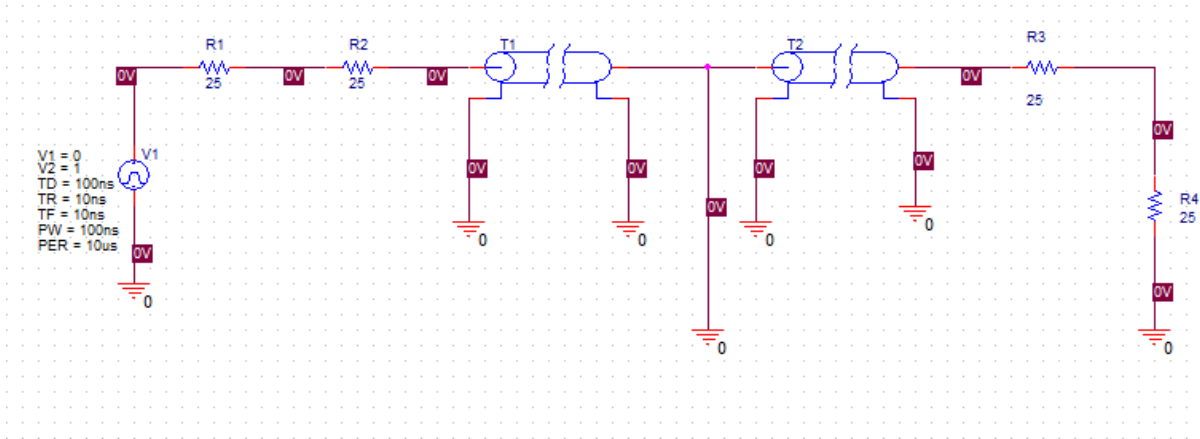

Fig. 3. PSpice simulation circuit diagram

III. RESULTS AND DISCUSSION

The Simulation Studies are carried out in MATLAB software. These work has been carried out in a 3-phase, 400 kV, 50 Hz and 200 km line cable is modeled as a distributed parameter line.

LG Fault

Line to ground fault occurs when line is grounded due to some disturbance. The Fig. 4. Shows the LG fault occurred in the line A.

From the Fig. 4., The fault is created at phase A, with respect to ground with a fault resistance value of 25 Ω, the value of current for phase B is 0.338 kA, and C is 0.39 kA throughout the simulation. The value of current in phase A is 0.133 kA before the fault produced, later the suddenly the value rises around 3.33kA. This shows the fault occurred at particular moment. Then, the value suddenly dips to the normal value of 0.133 kA.

LLG Fault

Double Line to Ground fault occurs, when two lines are short circuited and is in contact with ground.

From the Fig. 5., the fault is created at phase B and C, with respect to ground with a fault resistance value of 25 Ω, the value of current for phase A is 0.52 kA throughout the simulation. The value of current in phase B is 0.129 kA and C is 0.068 kA before the fault produced, later the value suddenly rises for phase B and C are around 4.2 kA and 4.5 kA respectively. Later the value suddenly dips to the normal value of 0.066 kA

LL Fault

A Line to Line fault is the one in which short circuiting occurs between two phases of the system. From the Fig. 6., the fault is created at phase C and A, with a fault resistance value of 25 Ω, the value of current for phase B is 0.136 kA throughout the simulation. The value of current in phase C is 0.127 kA and A is 0.131 kA before the fault produced, later the value suddenly rises for phase C and A are around 4.0 kA and 4.2 kA respectively. Later the value suddenly dips to the normal value of 0.064 kA

LLL Fault

This occurs due to breakdown of insulation between all the three phases.

From the Fig. 7. the fault is created at phase A, B and C with a fault resistance value of 25 Ω. The value of current in phase A is 0.129 kA, phase B is 0.135 kA, phase C is 0.119 kA before the fault produced, later the value suddenly rises for phase A, phase B and C are around 4.78 kA, 4.90 kA and 4.71 kA respectively, persist in the value until the relay in the three phase fault block operates to clear the fault. Later the value suddenly dips to the normal value of 0.073 Ka

Fuzzy Interference System

The fuzzy logic output variables for fuzzy classifier-I is shown in Fig. 9. By using this output variable, the type of fault is determined with the help of rule viewer.

The three triangular membership functions are used to find ground faults. Each input is designated as Small, Medium, Large. The ranges of membership functions are between -1.0 and -0.005 for small, value between 0.02 and 0.3 for medium, value between 0.2 and 1.0.

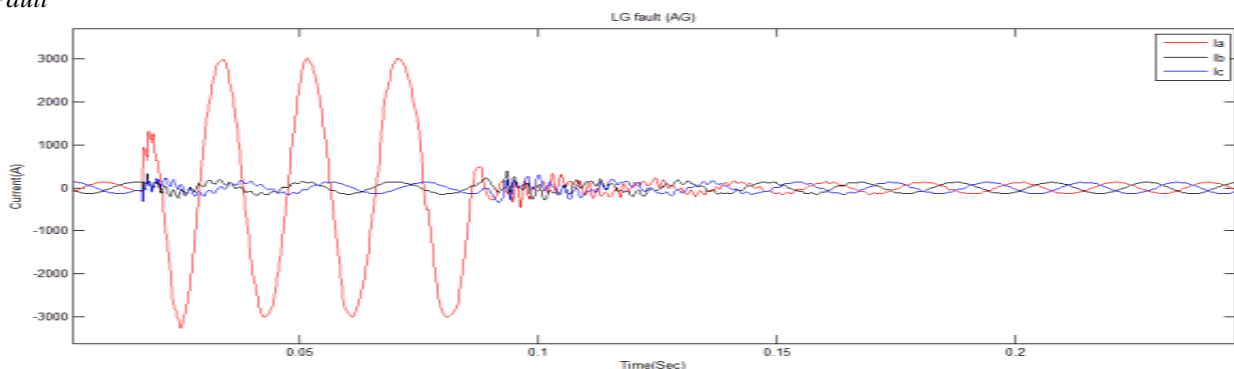

Fig. 4. LG Fault at phase A with fault resistance 25 Ω

Fuzzy Based Fault Classifier and Time Domain Reflectometry Based Fault Locator for Underground Cables

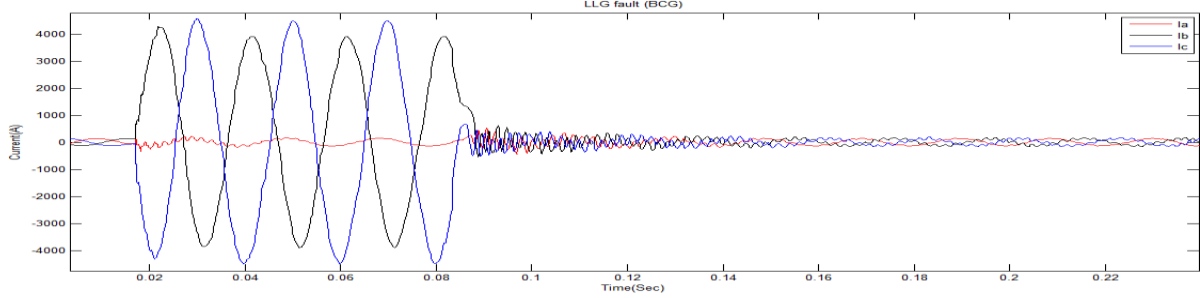

Fig. 5. LLG Fault at phase B & C with fault resistance 25 Ω

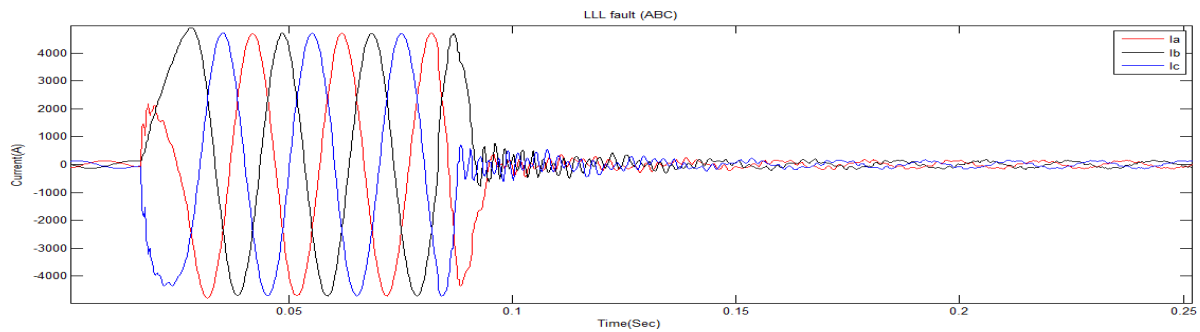

Fig. 6. LL Fault at phase C & A with fault resistance 25 Ω

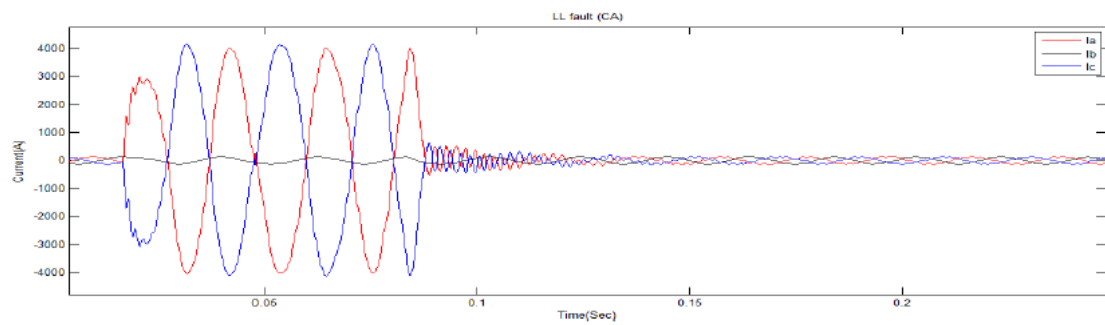

Fig. 7. LLL Fault at phase A, B & C with fault resistance 25 Ω

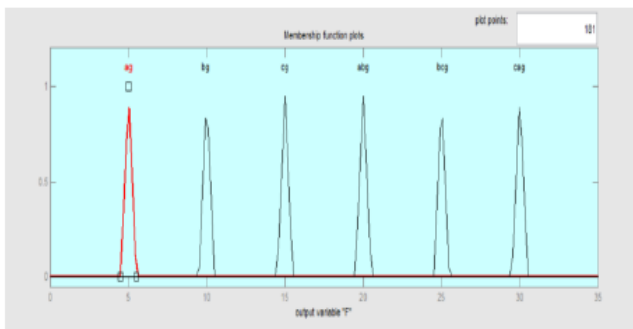

Fig. 9. Fuzzy Classifier I

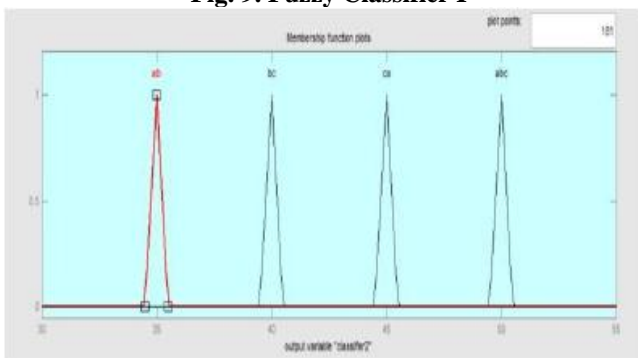

Fig. 10. Fuzzy Classifier II

Rules to find type of ground faults using S1, S2 and S3:
 If (S1 is Large) (S2 is Medium) (S3 is Small) then (trip output is AG).
 If (S1 is Small) (S2 is Large) (S3 is Medium) then (trip output is BG).
 If (S1 is Medium) (S2 is Small) (S3 is Large) then (trip output is CG).
 If (S1 is Small) (S2 is Large) (S3 is Small) then (trip output is ABG).
 If (S1 is Small) (S2 is Small) (S3 is Large) then (trip output is BCG).
 If (S1 is Large) (S2 is Small) (S3 is Small) then (trip output is CAG).

The three triangular membership functions are employed to find phase faults. Each input is designated as Small, Medium, Large. The ranges of membership functions are between -1.0 and -0.005 for small, value between 0.02 and 0.3 for medium, value between 0.2 and 1.0.

Rules to find type of phase faults using S1, S2 and S3:
 If (S1 is Small) and (S2 is Large) and (S3 is Small) then (trip output is AB).

If (S1 is Small) and (S2 is Small) and (S3 is Large) then (trip output is BC).
 If (S1 is Large) and (S2 is Small) and (S3 is Small) then (trip output is CA).
 If (S1 is Medium) and (S2 is Medium) and (S3 is Small) then (trip output is ABC).
 If (S1 is Small) (S2 is Medium) (S3 is Medium) then (trip output is ABC)
 If (S1 is Medium) (S2 is Small) (S3 is Medium) then (trip output is ABC).
 If (S1 is Small) (S2 is small) (S3 is Medium) then (trip output is ABC).

If (S1 is Medium) (S2 is Small) (S3 is Small) then (trip output is ABC).
 If (S1 is Small) (S2 is Medium) (S3 is Small) then (trip output is ABC).
 The fuzzy output for fuzzy classifier-II is shown in the Fig. 10.
Observation
 The observed values for four different types of faults such as LG, LL, LLG and LLL with two different fault resistances such as 25 Ω and 50 Ω is tabulated in table 1 and 2 and verified.

Table1. Output for Fuzzy classifier-I for ground fault

Type of Fault	= 25 Ω				= 50 Ω			
	S1	S2	S3	Output	S1	S2	S3	Output
AG	0.856	0.131	-0.986	4.9	0.832	0.149	-0.984	4.9
BG	-0.988	0.861	0.128	9.97	-0.983	0.846	0.137	10
CG	0.112	-0.983	0.871	15	0.094	-0.976	0.882	15
ABG	-0.906	0.986	-0.080	19.9	-0.867	0.967	-0.101	20
BCG	-0.094	-0.892	0.986	25	-0.105	-0.858	0.963	24.9
CAG	0.982	-0.087	-0.895	30.1	0.977	-0.088	-0.899	30

Table 2. Outputs for fuzzy classifier-II for phase faults

Type of Fault	= 25 Ω				= 50 Ω			
	S1	S2	S3	Output	S1	S2	S3	Output
AB	-0.965	0.9989	-0.033	35	-0.94	0.9972	-0.054	35
BC	-0.033	-0.965	0.9989	40	-0.05	-0.941	0.9969	40
CA	0.9989	-0.032	-0.966	45	0.997	-0.055	-0.942	45
ABC	-0.062	0.066	-0.004	50	-0.06	0.009	-0.003	50

Pspice Simulation

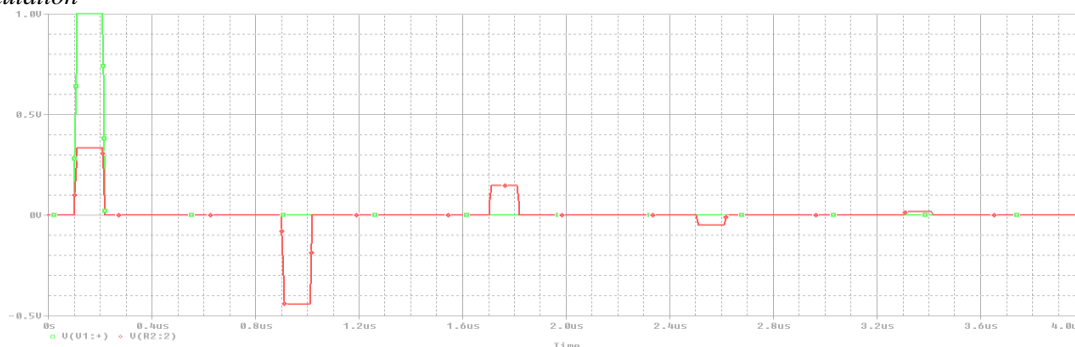

Fig. 11. LG fault voltage waveform

At time $t = 187 \mu s$, and the distance of the fault is given as the half of the distance travelled by the wave. Therefore, using equations (10, 11) The location of fault is calculated as, D. Fig. 11. shows an output response of the single line to ground fault. This graph is obtained by the three step process, the creation of underground cable system model using a Pspice simulink and followed by creation of faults in the system. In second step fault voltages and currents.

IV. CONCLUSION

Thus, this paper made the time consuming process of finding the type of error in cables ease with the help of MATLAB and fuzzy logic controller. The fault in the cable have been simulated in MATLAB and it is fed as input in fuzzy logic and the type of fault is found. The classification of faults is possible by taking into account of grounding. The location of fault is identified by time domain reflectometry principle that is simulated using PSpice. Further, the incipient faults in cable like minor cracks, moisture, and bending can also be realized

using fuzzy logic classifier after analysis of performance index.

ACKNOWLEDGEMENT

The authors express their thankfulness to the management of PSG Institute of Technology and Applied Research, India for their extensive facilities and support provided to address this research work.

REFERENCES

1. Allan Greenwood, 'Electrical Transients in Power systems', John Wiley & sons, Inc 2014.
2. Avagaddi Prasad, J. Belwin Edward, C. Shashank Roy, G. Divyansh and Abhay Kumar, 'Classification of Faults in Power Transmission Lines using Fuzzy-Logic Technique', 2015.
3. B.Bhuvneshwari, A.Jenifer, J.John Jenifer, S.Durga Devi, G.Shanthi, 'Underground Cable Fault Distance Locator', 2017.
4. Fonseca Badillo, L. NegreteNavarrete, A. Gonzalez Parada, A.



Fuzzy Based Fault Classifier and Time Domain Reflectometry Based Fault Locator for Underground Cables

- Castaneda Miranda, 'Simulation and analysis of underground power cables faults', 2012.
5. GotteVikramRaju, EbhaKoley, 'Fuzzy Logic Based Fault Detector and Classifier for Three Phase Transmission Lines with STATCOM', 2016.
 6. Gowrishankar, P. Nagaveni, P. Balakrishnan, 'Transmission Line Fault Detection and Classification Using Discrete Wavelet Transform and Artificial Neural Network', 2016.
 7. HadiSaadat, 'Power System Analysis', published by McGraw-Hill companies, 2014.
 8. Jiantao Sun, Xishan Wen, Xinlao Wei, Qingguo Chen, Yonghong Wang, 'Traveling Wave Fault Location for Power Cables Based on Wavelet Transform', 2007.
 9. Jitendra Pal Singh, Narendra Singh Pal, Sanjana Singh, Toshika Singh, Mohd.Shahrukh, 'Underground ground cable fault locator', Volume 3 Issue 1, 2006.
 10. John J. Grainger, William D. Stevenson, 'Power system analysis', published by McGraw-Hill. ISBN 0-07-113338- 0.
 11. KunalHasija, Abhishek Kumar, Shelly Vadhera, Anurag Kishore, 'Detection and Location of Faults in Underground Cable using MATLAB/Simulink/ANN and OrCad', 2014.
 12. Magdy B. Eteiba, Wael Ismael Wahba, ShimaBarakat, 'Accurate fault location algorithm for Underground Cables using Adaptive Network-Based Fuzzy Inference System and Discrete Wavelet Transform', 2014.
 13. Mahanty, P.B. Dutta Gupta, 'A fuzzy logic based fault classification approach using current samples only', 2007. [12]Mahmoud Gilany, Doaakhalil Ibrahim, El Sayed Tag Eldin, 'Traveling-Wave-Based Fault-Location Scheme for Multiend-Aged Underground Cable System', 2007.
 14. Mamta Patel, R. N. Patel, 'Fault Detection and Classification on a Transmission Line using Wavelet Multi Resolution Analysis and Neural Network', 2012.
 15. Mohamed Mamdouh Abdel Aziz, Doaakhalil Ibrahim, 'An PMU Double Ended Fault Location Scheme for Aged Power Cables', 2008.
 16. SekharamanthiriJyothsna, K. DurgaRao, T. SrinivasaRao, 'Fuzzy Logic Based Fault Detection and Classification of Unsynchronized Faults in Three Phase Double Circuit Transmission Lines', 2017.

AUTHORS PROFILE



Bavithra K., received her B.E., in Electrical and Electronics Engineering, M.E., in Power System Engineering in 2014, 2016, respectively, Anna University, India. Her research areas include optimization, security of power systems, machine learning applications in power system, deregulation. She is Currently working as assistant professor at PSG Institute of Technology and Applied Research, Coimbatore.



Latha R., received her B.E., in Electrical and Electronics Engineering, M.E., in Power System Engineering and PhD in 2001, 2005, 2014 respectively, from Anna University, India. Her research areas include optimization, security of power systems, machine learning applications in power system, deregulation. She is Currently working as Associate Professor at PSG college of Technology, Coimbatore.



Madhugogul P., studying B.E. Electrical and Electronics Engineering in PSG Institute of Technology and Applied Research, India. He is interested in soft computing, digital logics and renewable energy.



Devaprasath R, studying B.E Electrical and Electronics Engineering in PSG Institute of Technology and Applied Research , India. He is interested , digital logics and renewable energy.