

# A Transformerless Buck-Boost Converter with Single Switch



Channamma. S. Patil, M. S. Aspalli

**Abstract:** This paper introduces a modern, transformerless buck-boost dc-dc converter. In this topology, one active switch is used. The proposed buck-boost converter voltage gain is higher compared to the conventional buck-boost converter. With a moderate duty cycle, high voltage gain can be reached. The switch's voltage stress is minimal. As a consequence, the power switch's conduction loss is relatively low to improve efficiency. The converter is simple, hence it will be easy to control the proposed converter.

**Keywords:** Transformerless converter, High voltage gain, Voltage stress.

## INTRODUCTION

Environmental problems, such as climate change and global warming caused by increased carbon dioxide emissions, have been very important in recent years. Despite increasing exposure to environmental issues, low environmental and renewable energy impacts are the subject of energy generated from fuel cell systems. In emergency power systems and cars, fuel cells are an essential choice for fuel replacement. Fuel cells can be used as green energy by customers with low carbon dioxide emissions. As a result of steady operation with renewable fuel supply and high performance and reliability, the fuel cell has been increasingly recognised as an acceptable alternative source. With this fuel, there are some issues, such as high prices, but they have great features, such as high performance and small size. As a consequence, many applications need step-up and step-down voltage converters, such as portable devices, electronic devices for vehicles, etc. The cell has very wide output voltage fluctuations in order to produce the stabilised output voltage and thus the additional switching power source is necessary for the processing of the varying input voltage. Many types of non-isolated buck / boost converters [1]-[3] are available, including buck-boost converters, single-end primary inductor converters (SEPIC), Cuk converters, Zeta converters, Luo converters and their derivatives, etc. However, these converters function in continuous conduction (CCM) mode. Many types of non-isolated buck / boost converters [1]-[3] are available, including buck-boost converters, single-end primary inductor converters (SEPIC), Cuk converters, Zeta converters,

Luo converters and their derivatives, etc. However, these converters function in continuous conduction (CCM) mode. The effects of diodes, switches and equivalent series resistance (ESR) of capacitors and inductors [4] are low and limited, although the traditional efficiency of the buck-boost converter is supposed to be high. Several high boost converters have been suggested in order to achieve high performance and voltage gain, and the addition of a new control method is a reasonable choice for the use of the low-duty cycle. For instance, high step-up voltage gain is also achieved by using a low-duty cycle flyback converter. By increasing the transformer turn ratio, the voltage gain of the flyback converters can be enhanced. Although a significant step-up voltage gain can be achieved by the flyback converter, the power switches are subject to a voltage spike across the switches, and due to reverse recovery issues and leaking inductor, the converter efficiency is not strong. High voltage gain dc-dc converters with a coupled-inductor are suggested in [7-8]. A transformerless dc-dc converter with one active switch is presented in this article. The configuration of the converter is simple, so control of the converter will be easy. The voltage stress is lower than the output voltage in the power switch and diodes, so the switch conduction loss is low and the converter performance can be increased. As a universal power source, the converter operates. In the converter structure, only one switch is used and the greater voltage gain can be achieved with moderate duty cycle.

## IRELATED WORK

The paper [7] shows a novel, non-isolated buck-boost converter. For the conventional boost, buck boost, CUK, SEPIC and ZETA converters, the voltage gain given for the converter is higher than that, and high voltage with an appropriate duty cycle can be achieved. Only one switch is used by this converter. The voltage stress is mild via the switch. The switch's low on-state resistance can therefore be selected to decrease the switch's conductive level and increases the efficiency. Without CO<sub>2</sub> emissions, fuel cell energy systems can produce renewable energy efficiently and are nominated as an alternative to traditional energy sources. The paper [8] presents a new high-speed DC-DC converter for distributed energy resources, particularly for fuel cell conditioning systems. In order to improve the voltage gain and to distinguish between the higher and lower sides of the converter, the converter is fitted with a coupled bi-directional booster inductor, two transformers whose secondary sides are linked in series. The coupled inductor was used to remove the ripple of the input signal and the inductance of the leakage of the transformer is used to provide Zero current switching activity.

Revised Manuscript Received on October 30, 2020.

\* Correspondence Author

**Channamma. S. Patil**, Department of Electrical and Electronics Engineering, PDA College of Engineering, Kalaburagi, Karnataka, India. Email: Channammapatil1717@gmail.com

**Dr. M. S. Aspalli**, Department of Electrical and Electronics Engineering, PDA College of Engineering, Kalaburagi, Karnataka, India. Email: maspalli@gmail.com

© The Authors. Published by Blue Eyes Intelligence Engineering and Sciences Publication (BEIESP). This is an [open access](https://creativecommons.org/licenses/by-nc-nd/4.0/) article under the CC BY-NC-ND license (<http://creativecommons.org/licenses/by-nc-nd/4.0/>)

## A Transformerless Buck-Boost Converter with Single Switch

In [9], a new transformerless buck-boost dc-dc converter is introduced that optimises the topology architecture and voltage to overcome the disadvantages of the traditional step-up and step-down converter. The key benefit of the converter is that it has a quadratic voltage gain over the conventional buck-boost converter, which can operate in a wide range of output voltages, i.e. without prolonged duty cycle, the buck-boost converter can achieve high or low voltage gain. Furthermore, the output voltage of this buck-boost converter with the input voltage is common ground and its polarity is positive. A novel buck-boost dc-dc converter with high-voltage step-up and step-down capability was introduced in [10]. It has a simple layout with two power switches and four passive components with two diodes. The downside of this converter is that it needs two floating gate drivers for two switches, which raises the cost. So, this paper proposes a novel quadratic buck-boost converter to mitigate this problem, where the power switches have common ground with the input voltage and there is no floating gate driver.

A new design concept has been developed for an electric propulsion system for a hybrid car [11]. For the two basic functions of a car (going forward or in reverse), a scheme comprising two converters is suggested. The topology proposed will concentrate primarily on the reverse feature that involves a negative output converter. For this, the Luo converter and self-lift Luo converter elementary negative output are implemented and evaluated. The negative elementary output and the self-lift Luo converters are newly built DC-DC converters. It is also possible to do a step-up conversion from the positive DC voltage input to the negative DC voltage. The voltage lift method has been introduced to improve the performance of the elementary converter. Due to its simplicity and its relative ease of use, it was used. It was possible to get higher voltage gains because of this technique than in the case of the elementary converter. In modular photovoltaic (pv) power conditioning units, a high-efficiency dc-dc converter phase capable of controlling for optimum power point monitoring over a large number of input voltages is required. The paper [12] presents a new isolated topology capable of meeting the requirements for high efficiency over a large range of input voltages. This topology ensures best performance for the majority of the switching process due to low circulating currents zero voltage switching zvs and low-current switching of the primary side module output diode zcs and direct load transfer. Also, by modulated control of the basic fixed frequency pulse length, this topology may provide voltage regulation. By simply adding a secondary bi-directional ac switch to an isolated series resonant converter, these characteristics can be achieved. The high performance and wide range of operation of this converter allows applications with PV micro converters to be used load current.

### II PROPOSED SYSTEM

Figure 1 shows the circuit diagram of proposed non-isolated buck-boost converter. It consists of only one power switch  $S_1$ , five diodes  $D_1, D_2, D_3, D_4, D_5$ , three inductors  $L_1, L_2, L_3$ , three capacitors  $C_1, C_2$  and  $C_3$ , and load  $R$ .

For analysis of proposed converter, the following assumptions are considered

- The proposed converter capacitors  $C_1, C_2$  and  $C_3$  are high enough. Therefore, it is presumed that the voltage between them is stable.
- Switches are optimal.
- Inductor values  $L_1$  and  $L_2$  are similar.

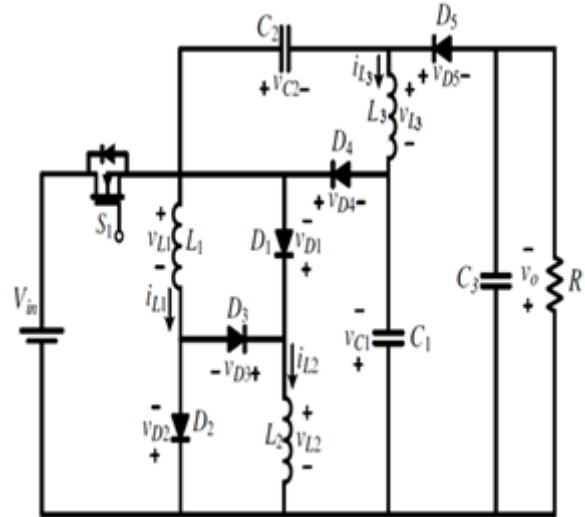
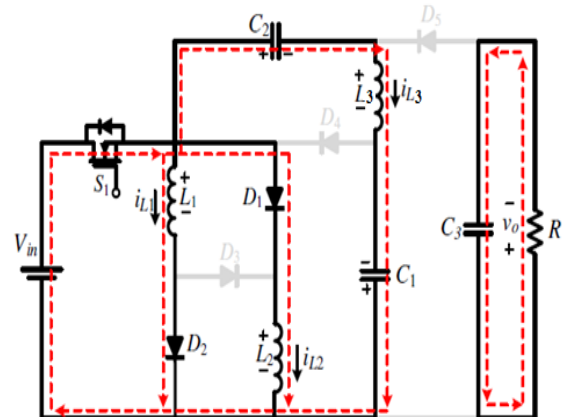

**Figure 1: Circuit diagram of the proposed converter**

In continuous conduction mode (CCM), the suggested non-isolated buck-boost converter can be worked. It is possible to break the continuous mode of conduction into 2 operating modes. The study of the proposed converter is defined in one switching time as follows:

- 1) **Mode I:** In this mode,  $S_1$  is switched on whereas  $D_1$  and  $D_2$  are switched-on and  $D_3, D_4$  and  $D_5$  are switched-off. Figure 2(a) shows the current-flow direction of the proposed converter. Inductors  $L_1, L_2$  and  $L_3$  are magnetised, and they boost the current flowing through them.  $C_1$  and  $C_3$  are being unloaded. Hence, this mode's voltage equations are:

$$\begin{aligned} V_{L1} &= V_{in} \\ V_{L2} &= V_{in} \\ V_{L3} &= V_{C1} + V_{in} - V_{C2} \end{aligned} \quad (1)$$



**Figure 2 (a): current- flow path of the proposed converter for Mode I**

2) **Mode II:** In this mode,  $S_1$  is switched-off.  $D_1$  and  $D_2$  are reverse-biased, and the forward-biased are  $D_3$ ,  $D_4$  and  $D_5$ . In this mode, the current-flow path of the proposed converter is shown in Figure 2 (b). Inductors  $L_1$ ,  $L_2$ ,  $L_3$  are demagnetized linearly whereas capacitor  $C_1$  is charged by inductors  $L_1$  and  $L_2$ . In addition output capacitor  $C_3$  is charged through  $C_1$  and  $C_2$ . Based on Figure 2 (b), this mode's voltage equations are as follows:

$$\begin{aligned} V_{L1} + V_{L2} &= -V_{C1} \\ V_{L3} &= V_{C2} \\ V_o &= V_{C1} + V_{C2}. \end{aligned} \quad (2)$$

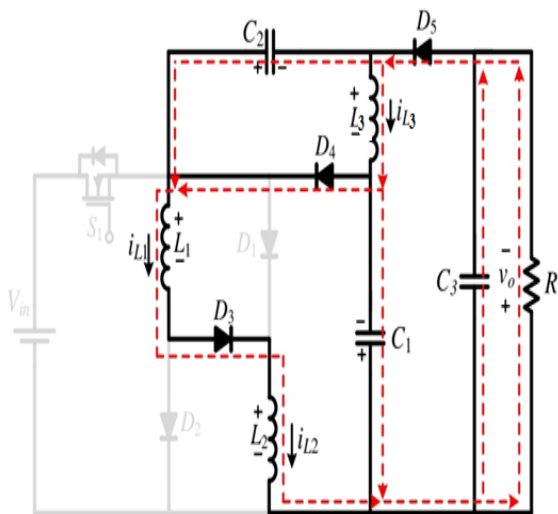

Figure 2 (b): Current-flow path of the proposed converter for Mode II

**IVSIMULATION RESULTS**

Using MATLAB/Simulink, the proposed transformerless buck-boost converter is simulated using MOSFET as a switching device. The transformerless step-up / step-down converter simulation parameters are shown in Table I. The suggested model for the step-up and step-down mode is shown in Fig. 3(a) and 4(a). The simulation studies for the proposed boost and buck mode converter are shown in Fig.3 (b) and 4 (b).

**TABLE I  
SIMULATION PARAMETERS**

Parameters	Step-up Mode	Step-down Mode
$V_{in}$	24 V	24 V
$V_o$	53V	16V
$f_s$	33 kHz	37 kHz
$L_1, L_2$	0.6 mH	0.6 mH
$L_3$	1.5 mH	1.5 mH
$C_1$	68 $\mu$ F	68 $\mu$ F
$C_2$	110 $\mu$ F	110 $\mu$ F
$C_o$	48 $\mu$ F	48 $\mu$ F

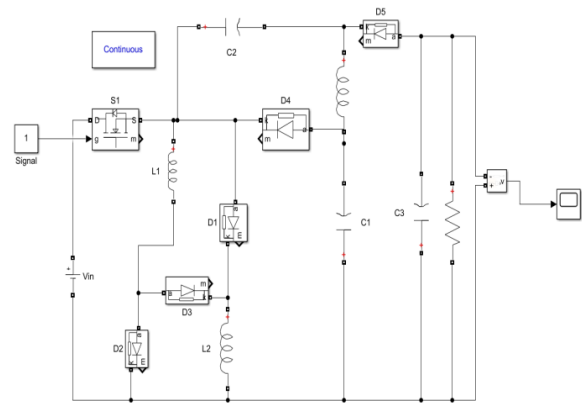

Figure.3 (a). Proposed design for 24V input to 53Vdc output for Boost Mode



Figure.3 (b). Simulation result for 24V input to 53V dc output for Boost Mode

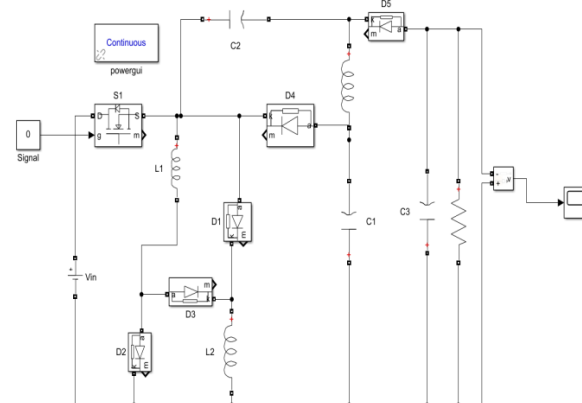

Figure.4 (a). Proposed design for 24V input to 16V dc output for Buck Mode

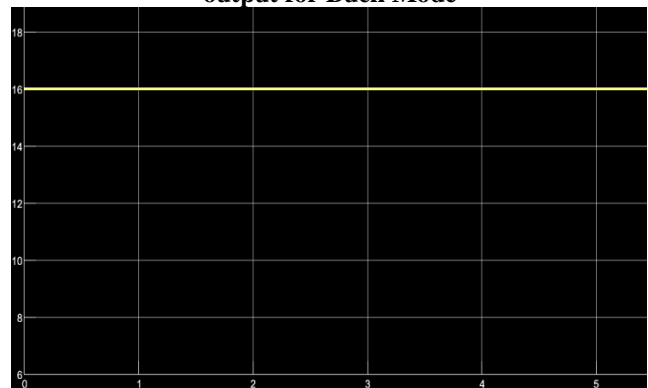

Figure.4 (b). Simulation result for 24V input to 16V dc output for Buck Mode

## VCONCLUSION

A transformerless buck-boost converter is introduced in this paper. The structure of the step up and step down converter is very basic. The proposed converter uses only one key switch, in order to remove the conduction failure of the switch. The step-up voltage gain of the suggested step-up/step-down converter is greater than the standard buck, boost, buck-boost, and CUK converters. With the satisfactory results of the MATLAB / Simulink model, the proposed topology of a single-switch transformerless buck-boost dc-dc converter is checked. The outcome of the simulation was a transformerless step-up/step-down converter whose  $V_{in}=24V$  increased to 53V and decreased to 16V. In some applications, such as fuel cell systems, LED drivers etc., the buck-boost converter is used.

## REFERENCES

1. Channamma.S.Patil,M.S.Aspalli,“A Transformerless Buck-Boost dc-dc converter with single switch,” *IITEE Journal*, vol 9, no.3, pp. 347-352, Jun 2020.
2. R. J. Wai, C. Y. Lin, R. Y. Duan, and Y. R. Chang, “High-efficiency DC–DC converter with high voltage gain and reduced switch stress,” *IEEE Trans. Ind. Electron.*, vol. 54, no. 1, pp. 354–364, Feb. 2007.
3. T. J. Liang, J. H. Lee, S. M. Chen, J. F. Chen, L. S. Yang, “Novel Isolated High-Step-Up DC–DC Converter With Voltage Lift,” *IEEE Trans. Ind. Electron.*, vol. 60, no. 4, pp. 1483-1491, Apr. 2013.
4. G. Spiazzi, P. Mattavelli, A. Costabeber, “Effect of Parasitic Components in the Integrated Boost-Flyback High Step-Up Converter,” *IECON '09. 35th Annual Conference of IEEE*, pp. 420 – 425. Nov. 2009.
5. A. Ajami, H. Ardi and A. Farakhor, “Design, analysis and implementation of a buck-boost DC/DC converter”, *IET Power Electronics*, vol. 7, no. 12, pp. 2902-2913, 12 2014.
6. K. I. Hwu and W.Z. Jiang, “Isolated step-up converter based on flyback converter and charge pumps,” *IET Power Electron.*, vol. 7, no. 9, pp. 2250–2257, Sep. 2014.
7. Sarikhani, B. Allahverdienejad and H. Torkaman, “A transformerless buck-boost DC-DC converter with single switch,” 2018 9<sup>th</sup> *Annu. Power Electron, Drives Sys. And Tech. Conf.(PEDSTC)*, Tehran, 2018, pp.369-373.
8. H. Torkaman, N. Karami, and M. M. Nezamabadi, “Design, Simulation, Validation and Comparison of New High Step-up Soft Switched Converter for Fuel Cell Energy System,” *Journal of Energy Management and Technology*, vol. 1, no. 1, pp. 53-60, 2017.
9. S. Miao, F. Wang and X. Ma, “A New Transformerless Buck-Boost Converter With Positive Output Voltage”, *IEEE Transactions on Industrial Electronics*, vol. 63, no. 5, pp. 2965-2975, May 2016
10. A. Mostaan, S. A. Gorji, M. Soltani and M. Ektesabi, “A novel quadratic Buck-Boost DC-DC converter without floating gate-driver”, 2016 *IEEE 2nd Annual Southern Power Electronics Conference (SPEC)*, Auckland, 2016, pp. 1-5
11. A. Cocor, A. Baescu, and A. Florescu, “Elementary and self-lift negative output Luo dc-dc converters used in hybrid cars”, *U.P.B. Sci. Bull., Series C*, Vol. 77, Iss. 4, pp. 179-190, 2015.
12. T. LaBella, W. Yu, J. S. Lai, M. Senesky and D. Anderson, “A Bidirectional-Switch-Based Wide-Input Range High-Efficiency Isolated Resonant Converter for Photovoltaic Applications”, *IEEE Transactions on Power Electronics*, vol. 29, no. 7, pp. 3473-3484, July 2014.

## AUTHORS PROFILE



**Channamma.S.Patil** received the B.E degree in Electrical and Electronics Engineering in 2018 from Visvesvaraya Technological University, Belagavi,. Godutai Engineering College for Women, Kalaburagi



**Dr. M.S.Aspalli** received the B.E. degree in Electrical Engineering in 1991, M.E. in Power Electronics in 1997 and Ph.D. in 2014 from Gulbarga University, Gulbarga. He started his career as a lecturer in Electrical Department at P.D.A.College of Engineering, Gulbarga and now he is working there as Professor and P.G.Coordinator for Post Graduate course in Power Electronics under the Department of

Electrical and Electronics Engineering. His fields of interest are Power Electronics and Drives, Power Quality Issues, Electric Vehicles' and its control. He has published more than 60 papers in national and international journals and conferences and he has published a book titled “Microcontroller Based Controller for Three Phase Induction Motor” with (ISBN-978-620-0-5349-8) publishers: Lambert Academic publishing. He is life member of FIE, ISTE, IETE, ISLE and ISCA. He has attended and awarded the certificate for The AICTE-UKIERI Technical Leadership Program i.e UK-INDIA Education and Research Initiative Program which is jointly organized by Dudley College, UK and AICTE New Delhi. He has more than 20 years of experience and he has taught different subjects at UG and PG. At present he is guiding 03 research scholars.