

# Improved Whale Optimization with Buffer Setup Time



K.Anandapadmanabhan, V. P. Eshwaramurthy

**Abstract:** *The job shop problem is widespread in industrial applications due to lateness in getting a better solution. Buffer plays an important role in the completion of jobs. Proper utilization of buffer by fixing optimal buffer setup time can lead to optimal completion time so that lateness is minimized. This work introduced Improved Whale Optimization with Buffer Setup time Technique (IWOBS) for setting optimal buffer setup time. Using tabu movements, an optimum solution for the nearest buffer setup time is derived and the genetic algorithm is equipped to find fitness score to gather the best buffer setup time with respect to problem consideration. The proposed IWOBS algorithm is proved to be highly effective compared to other existing algorithms.*

**Keywords:** *buffer, job shop problem, setup time, Whale Optimization Algorithm*

## I. INTRODUCTION

Generally, the Job Shop Scheduling Problem (JSSP) has occurred in the job scheduling process in some machines or resources at a certain time period. Many researchers had expanded the theoretical models of the JSSP from the mid-50s forwards and several algorithms are employed to resolve them. Some of them had reviewed several method and some had analyzed and categorized those methods. The JSSP problem has solved in this work through the proposed genetic algorithm and tabu search using the IWOBS technique.

The whale optimization algorithm (WOA) is a new optimization technique for solving optimization problems. This algorithm includes three operators such as encircling prey, search for prey and hunting prey of humpback whales. The WOA algorithm is improved in this work. IWOBS includes three operators based on buffers such as encircling buffer, search for optimum buffer and hunting buffer. An optimal buffer is identified with the help of these operators.

In this work, buffer plays a major role. Buffer is a region of physical memory storage used to temporarily store data while it is being moved from one place to another. There are three types of buffers used to find the optimum one such as limited buffer, blocking buffer and unlimited buffer but these three types of buffers have some problems between the processes of job scheduling. This problem is rectified by the proposed setup time buffer using Improved Whale Optimization with Buffer Setup time i.e. hunting buffer based on the threshold value.

For an embedded heuristic technique, tabu search is a Metaheuristic, global optimization and meta-strategy algorithm. The structures of memory have been introduced in Metaheuristic that are parallel tabu search and reactive tabu search. Tabu is a parent for a derivative approach of a large family. Cycling is the main objective of the tabu search algorithm that is the process of returning an embedded heuristic to the search spaces which is the recently visited area. Two different types of memory named as long-term and short-term memory that need to be maintained by the strategy of an approach. The tabu movements are maintained in the short-term memory which is recently visited. The history of all tabu search processes are maintained in the long-term memory. Only the tabu move will be considered when the result obtains a better solution than the solution of the best trial which founded previously (Aspiration Condition).

The selection of fittest individuals for reproduction to produce the next generation's offspring in the process of genetic algorithm is known as the natural selection. The inherited offspring and the next generation contain the parents' characteristics. The offspring have better fitness and surviving chance than their parents when their parents having better fitness. This process will be repeated while finding all fittest individuals.

How the individuals are fit while comparing with other individuals has been calculated through the process of the fitness function. Every individual has a separate fitness score. Based on this fitness score, the individual has been selected for reproduction through probability. Thus this work is proposed using tabu to generate optimal buffer setup time and genetic algorithm to find fitness value of buffer setup time which is the most suitable setup time for buffer.

The contributions of this work are as follows.

- Two heuristic algorithms are used and improved the WOA for solving the job shop scheduling problem.
- Find the optimal buffer setup time with the help of the IWOBS technique.
- Optimum buffer is identified by threshold value and it is initialized at the beginning of the hunting buffer step.
- Get the fitness score for optimum buffer using a genetic algorithm
- Minimizing the lateness by the optimum buffer.

**Revised Manuscript Received on December 30, 2019.**

\* Correspondence Author

**K.Anandapadmanabhan\***, MCA, M.Phil, Assistant Prof. & Head of Computer Science, Sri Vasavi College, Erode. (Self Finance Wing) Bharathiar University (Category B), [Kapn0305@gmail.com](mailto:Kapn0305@gmail.com)

**Dr V. P. Eshwaramurthy**, Asst. Prof. of Computer Science, Komarapalayam Arts And Science College, Komarapalayam. [Eswar\\_Murthy@yahoo.com](mailto:Eswar_Murthy@yahoo.com)

© The Authors. Published by Blue Eyes Intelligence Engineering and Sciences Publication (BEIESP). This is an [open access](https://creativecommons.org/licenses/by-nc-nd/4.0/) article under the CC-BY-NC-ND license <http://creativecommons.org/licenses/by-nc-nd/4.0/>.

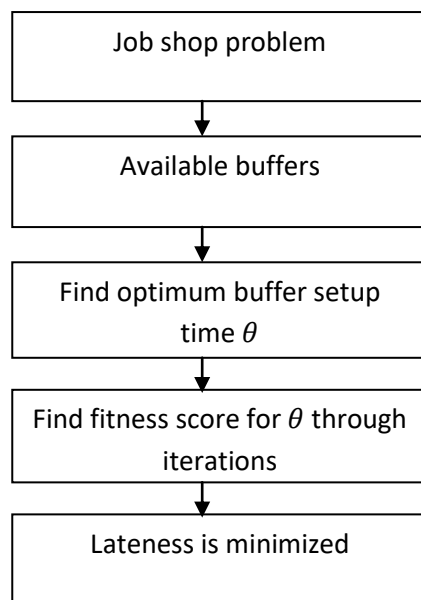

**Fig 1: Flow diagram**

## II. LITERATURE SURVEY

Yuan et al [1] proposed an enhanced fuzzy model with two different fuzzy objectives for solving the fuzzy multi-objective flow shop scheduling problem. They also determined the fuzzy makespan, the fuzzy total flow time and fuzzy multi-objective local search through the decomposition algorithm. Initially, they included the Nawaz–Encore–Ham heuristic approach in the framework of their work.

Rizkya et al [2] developed an NEH algorithm for the furniture industry to solving the production scheduling problem. The NEH helps to reduce the product’s total processing time, so the product gets finished on the correct time. In the furniture industry, the FCFS (First Come First Serve) scheduling system has utilized for the scheduling of production.

Liu et al [3] proposed a Nawaz-Encore-Ham (NEH) heuristic which describes the permutation flow shop for solving the scheduling problem. They developed a novel tie-breaking rule for minimizing a partial idle time and also developed a new priority rule through skewness utilization.

Wang et al [4] determined the multi-objective parallel neighborhood search algorithm for solving the blocking flow shop problem. An improved Nawaz-Encore-Ham helps to generate the initial solutions which are based on a heuristic. The variable neighborhood search has designed these solutions and which are discovered in parallel.

Ali et al [5] presented a tabu search algorithm with the heuristic technique for handling the job shop scheduling problem. They generate consistent completion time with various schedules using this tabu search algorithm.

Schaller and Valente [6] proposed the job scheduling method based on dispatching rules for solving the permutation flow shop problem. They used unforced idle time for reducing the tardiness and the earliness of jobs then they enhanced the without the unforced idle time and tested their work with different dispatching heuristic algorithms.

Li et al [7] developed the backward method for E/T criteria and initialized the characteristics of the problem and

the objective features for a group of solutions. Five different types of neighborhood structures have used for enhancing the exploration and exploitation.

Fattahi et al [8] described the job shop scheduling problem. They provide two different solutions for this problem with their advantages and weaknesses in the research solution space of searching for an adequate solution.

Ashhab and Mlybari [9] proposed the multi-objective scheduling optimization which using a genetic algorithm to minimize the earliness, makespan, tardy and tardiness of jobs. It can easily optimize those minimization criteria.

Golmohammadi et al [10] developed a new mathematical model for minimizing the earliness tardiness objectives. This proposed model used for solving small scale problems such as the optimal solution’s availability and NP-hard. They used the genetic algorithm for solving large scale problems.

Peng et al [11] presented a technique named mixed-flow shop scheduling (MFSS) to minimize energy consumption, non-processing energy (NPE) reduction and Tardiness Fine (TF). Two parts have presented in this technique that is the multi-objective evolutionary algorithm and the mathematic model with multi-chromosomes (MCEAs).

Yazdani et al [12] proposed a model called mixed-integer linear programming (MIP) which calculates the tardiness and the sum of maximum earliness. They also developed an imperialist competitive algorithm with an effective neighborhood searching technique for solving the job shop scheduling problem based on a new approximate optimization approach.

Han *et al.* [13] implemented an Improved Whale Optimization Algorithm (IWOA) as an inflexible flow shop, a global optimization algorithm and the mathematic programming model with limited buffer times. Based on the WOA, the implemented algorithm uses simulated annealing, levy flight, and opposition-based learning strategy.

Nezhad and Abdullah [14] presented the job shop scheduling problem (JSSP) that works with the set of machines and jobs as well as pre-settled routes and the objective minimizing such as total maximum lateness, makespan, and weighted tardiness. Reddy *et al.* [15] determined the optimal DG size and developed a WOA model with the basis of humpback whales WOA’s unique hunting behavior. They had tested their index vector and WOA method with various types of evolutionary algorithms, the voltage sensitivity index method and DGs. Basset et al. [16] developed a novel Modified version of WOA (MWOA) for the cryptanalysis of MHKC. The continuous values are mapped into a discrete one using a sigmoid function. The evaluation function adds a penalty function for dealing the infeasible solutions and the solution had improved by the employment of mutation operation.

### WHALE OPTIMIZATION ALGORITHM

The unique hunting method is also known as bubble-net predation method of a humpback whale which is the basis of the whale optimization algorithm (WOA) [16].

The observation of distance between him and surround the prey & the prey has made through the humpback whale. The spiral path is used by the humpback whale with 15 m deep and various sized bubbles have spit. The first and last spit out bubbles rose to the surface concurrently so the tubular or cylindrical bubble network has formed. It makes the prey near the center of the net and it's like a vast spider knotted web to frame the prey strongly. So the humpback whales practically swallow the prey in the net and in the bubble circle, it almost upright open mouth. Encircling prey, searching for prey and spiral bubble-net feeding maneuver are the three steps of the humpback whale's hunting behavior that is based on the above description.

III. METHODOLOGY

A. IMPROVED WHALE OPTIMIZATION ALGORITHM (IWOA)

**Step 1: Encircling prey:** The prey gets encircled through humpback whales' searching process. The following mathematical model is abstracts this behavior.

$$D = |CX^*(t) X(t)|$$

The current iteration is represented as T. The humpback whale's best position is indicated as  $X^*(t)$  that is until the current generation. The whales' location at the moment is denoted as  $X(t)$ .

**Step 2: Search for prey:** Search for prey's mathematical model is declared as follows:

$$D = |CX_{rand} X(t)|$$

Where the position of any whale in a population is represented as  $X_{rand}$  which helps to update the whale's current position.

**Step 3: Hunting prey:** In a spiral motion, the humpback whale swims to the prey in this hunting prey process and the following mathematical model has abstract this process:

$$D = |X^* X(t)|$$

The whale's best position is indicated as  $X^*(t)$  at present.

B. Improved Whale Optimization with Buffer Setup time Technique (IWOA)

IWOA algorithm is enhanced in this work in efficient buffer setup time calculation so that the jobs are executed with optimal buffer hence the lateness of the completion time is minimized.

$B \in \{lb, ub, bb\}$  or  $B = \{lb, bb, ub\}$  calculate the Whale Optimization Algorithm (WOA) with buffers and it can be improved in the third step of (WOA) with Buffer.

Step 1: Encircling buffers

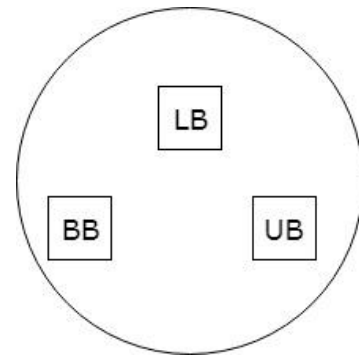

Fig 2: Encircling buffers

The above diagram denotes the available buffers for the job shop problem. Job is processed on the machine while producing the data which is stored to the buffer. Buffer is the memory storage used to store the data temporarily. In fig. 2, LB denotes Limited Buffer, BB denotes Blocking Buffer, UB denotes Unlimited Buffer.

Step 2: Searching for optimum buffers:

In order to perform the above job shop scheduling, an optimal buffering technique is searched and discussed the short comes of all the existing buffer techniques here.

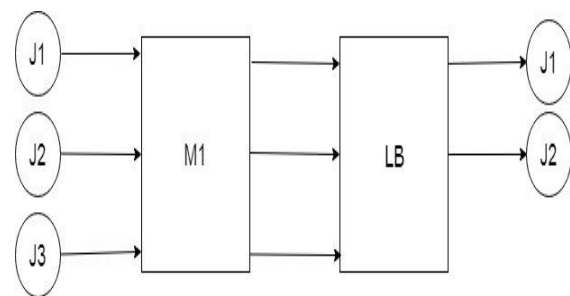

Fig 3: Limited Buffer

The above diagram denotes that jobs J1, J2, J3 are processed on machine 1. After processing, the jobs are stored in the buffer. After storing, the buffer delivers only two jobs due to limited buffer. So only limited jobs are delivered.

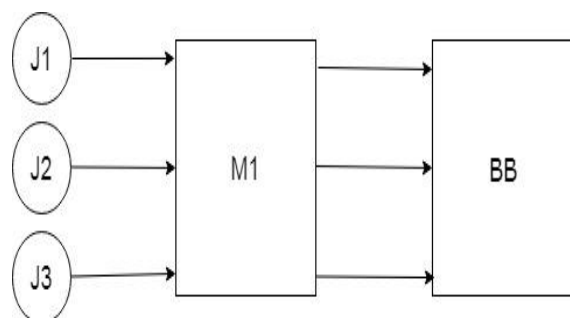

Fig 4: Blocking Buffer

The above diagram denotes the job J1, J2, J3 is processed on machine 1. After processing, the jobs are stored in the buffer. After stored, a buffer cannot deliver any jobs due to blocking buffer is used, so jobs are fully blocked in this buffer. So no output arrived.

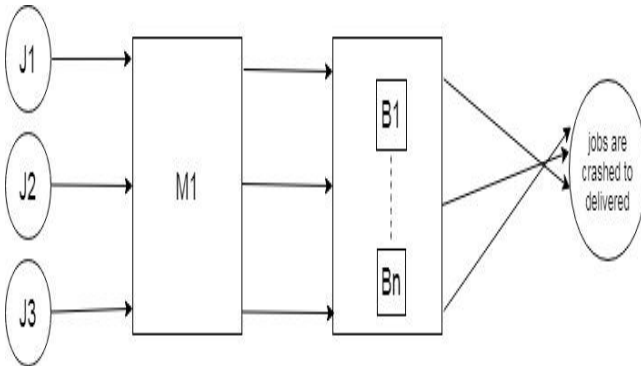

Fig 5: Unlimited Buffer

The above diagram denotes the job J1, J2, J3 is processed on machine 1. After processing, the jobs are stored with collapse because all the jobs are unaware of which buffers are used to store. After stored, buffer delivers the job with defects due to unlimited buffer is used so the jobs are crashed to deliver. In order to handle all the above three problems, hunting buffer is introduced here.

**Step 3: Hunting buffer:**

Thus an optimum buffer is introduced in this work called Setup time buffer.

- In this step, the buffer is improved and the storage time of buffer is calculated. A threshold value is set to default i.e.  $\theta \leq 5$ .
- The value 5 denotes the minutes for a storage time of buffer. And it helps us to minimize the lateness of delivered jobs.
- The aim of this work is to find the optimum buffer with time so insert the setup time to the buffer (*insert Setup time*).
- The tabu movement is used while the condition or solution arrived which is satisfied than the previous one. Satisfying a condition or solution is the optimum one.
- Get the fitness score after optimum buffer with time is found.

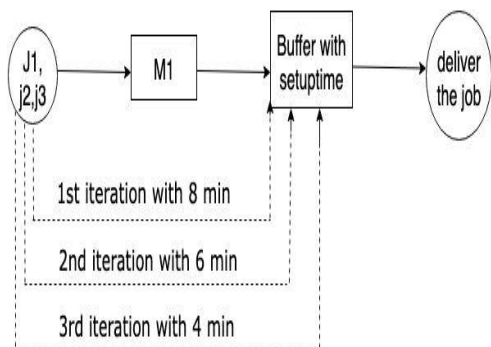

Fig 6: Hunting buffer

The above diagram denotes the optimum buffer with less time with the help of the IWOBS technique. The tabu movement is applied at 3<sup>rd</sup> iteration because the condition is optimal than the previous one and also that is less than the  $\theta$  value. The optimum buffer is found at 3<sup>rd</sup> iteration. The jobs are delivered with less time compare to lb, bb, and ub so the lateness is minimized with the help of the Setup time technique.

**CALCULATING THE FITNESS SCORE**

The genetic algorithm represented each solution as a string of binary numbers which is known as a chromosome. The solutions are to be tested and the best set of solutions is to be found to solve the given set of problems. Fig. 3 to 5 defined three sets of solutions. Each solution defined the storage time of the buffer. According to the fitness score, the best solution or optimum solution from the set of solutions is found. The optimum solution is found in the hunting buffer step that is 4 and also the fittest score is 4 because the condition is satisfied as well as the lateness is minimized at 3<sup>rd</sup> iteration. The jobs are delivered with 4 minutes buffer setup time.

**IV. RESULT AND DISCUSSION**

IWOA used limited buffer scheduling problems in a flexible flow shop with setup times and they didn't clearly explain the buffer storage time. But this IWOBS technique clearly explained the setup time and also the storage time of buffer and also minimized the lateness of the jobs.

**Table 1: Job's lateness in three different buffers**

JOBS	LATENESS OF JOBS (min)		
	IWOA	IWOBS	Without buffer
J1	5	4	9
J2	4	3	8
J3	6	5	7

Table 1 contains the lateness of job value between existing, proposed and without buffer. The lateness of jobs is reduced in this work.

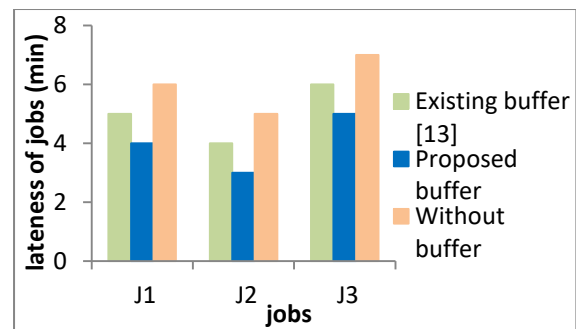

Fig 7: comparison of the lateness of jobs between buffers

In fig 4 denotes the lateness comparison of proposed work with existing and without buffer. The lateness is reduced in this work because the processing time is low so the lateness of jobs reduced compare to others. The lateness is maximized in existing work because the processing time is high. The lateness is too high without buffer works compare to proposed and existing because the storage time processing time of jobs is extending.

Table 2 contains the buffer's capacity values with percentages. The total numbers of the job are processed in limited, blocking, unlimited, setup time buffers and calculate the capacity of these four buffers.

**Table 2: Buffers Capacity**

NO OF JOBS	CAPACITY OF BUFFERS (%)			
	LIMITED	BLOCKING	UNLIMITED	SETUP TIME
3	34	25	56	73
4	36	29	67	77
5	38	35	70	83

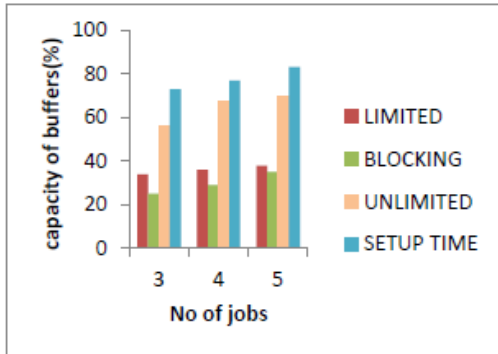

**Fig 8: comparison between the four types of buffer**

In fig 5 denotes the buffer's capacity. The total number of jobs processed in the limited buffer but they have less capacity because they delivered only the limited jobs. The total number of jobs processed in blocking buffer but it has less capacity because jobs are blocked at buffer storage. The total number of jobs processed in the unlimited buffer but it has less capacity because jobs couldn't know to store the unlimited buffers. Compare to previous buffers setup time have more capacity because the proposed technique inserts the setup times for buffers so the jobs are delivered easily without defects.

**Table 3: Finding the best solution**

NO OF ITERATIONS	BEST SOLUTION $\theta < 5$ (min)	
	IWO	IWOBS
1	10	8
2	8	6
3	7	4
4	6	3
5	4	2

Table 3 contains the optimum solution found with the number of iterations compare between the existing work and proposed work.

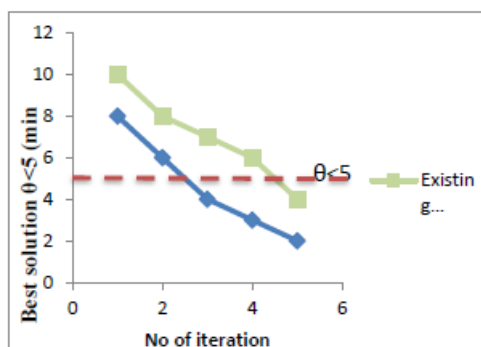

**Fig. 9 Comparison to time to get the best solution**

In fig 6 denotes the found the optimum solutions are outperforming with conditions  $\theta < 5$ . In fig 6 the dotted line denotes the  $\theta$  value. it should be less than 5. In this work found the best solution in 3<sup>rd</sup> iteration because the condition is satisfied earlier. In existing work, the best solution is found in the 5<sup>th</sup> iteration because the condition satisfied later. In this work numbers of iterations are reduced to finding the optimum solution compare to existing.

**V. CONCLUSION**

This paper determines the job shop scheduling problem by improved whale optimization with buffer setup time (IWOBS). This work calculated the optimum buffer from the buffer types. After some assessments, found the optimum buffer with a certain threshold condition. Then choose the optimum solution and get the fitness score and minimized the lateness with fewer iterations. Finally proposed work explores the efficient and less computation time compared to the existing work.

**REFERENCES**

- Fuyu Yuan, XinXu and Minghao Yin, "A novel fuzzy model for multi-objective permutation flow shop scheduling problem with fuzzy processing time", Advances in Mechanical Engineering, 2019.
- Rizkya, K Syahputri, R M Sar, I Siregar, M MTambunan, Anizar, U arigan, and N Isnaini, "Nawaz, Enscore, Ham (NEH) Algorithm To Minimization OfMakespan In Furniture Company", IOP materials science and engineering, 2019.
- Weibo Liu, Yan Jin, and Mark Price, "A new improved NEH heuristic for permutation flowshopscheduling problems", International Journal of Production Economics, 2017
- Fucaiwang, Guanlongdeng, Tianhua Jiang and Shuningzhang, "Multi-Objective Parallel Variable Neighborhood Search for Energy Consumption Scheduling in Blocking Flow Shops", IEEE Access, 2018.
- Md. Hasan Ali, Md. RashedulHaque and Md. Fashiar, Rahman "Machine Utilization Technique for Job Shop Scheduling using Tabu Search Algorithm", International Journal of Advance Industrial Engineering, 2018
- JeffreySchaller and JorgeM.S.Valente, "Heuristics for scheduling jobs in a permutation flow shop to minimize total earliness and tardiness with unforced idle time allowed", Elsevier, 2018.
- Jun-qiang li, peiyongduan, jindecao, xiao-ping lin, and yu-yanhan, "A Hybrid Pareto-Based Tabu Search for the Distributed Flexible Job Shop Scheduling Problem With E/T Criteria", IEEE Access, 2018.
- ParvizFattahi, MasumeMessiBidgoli and ParvanehSamouei, "An Improved Tabu Search Algorithm for Job Shop Scheduling Problem Trough Hybrid Solution Representations", Journal of Quality Engineering and Production Optimizations, 2018.
- M. S. Al-Ashhab and E. A. Mlybari, "Multi-Objective Scheduling Using GeneticAlgorithms", International Journal of Engineering and Technology, 2018.
- Amir-Mohammad Golmohammadi, Hamid Bani-Asadi, HamedJafarZanjani and Hamid Tikani, "A genetic algorithm for preemptive scheduling of a single machine", International Journal of Industrial Engineering Computations, 2016.
- Chen Peng, Tao Peng, Yi Zhang, Renzhong Tang, and Luo ke Hu, "Minimising Non-Processing Energy Consumption and Tardiness Fines in a Mixed-Flow Shop", Energies, 2018.
- Maziar Yazdani, AldeidaAleti, Seyed Mohammad Khalili and FariborzJolai, "Optimising the sum of maximum earliness and tardiness of the job shop scheduling problem", Computers & Industrial Engineering, 2017.
- Zhonghua Han, Quan Zhang, Haibo Shi, Yuanwei Qi, and Liangliang Sun, "Research on Limited Buffer Scheduling Problems in Flexible Flow Shops with Setup Times", International Journal of Modelling, 2018.



## Improved Whale Optimization with Buffer Setup Time

14. Majid Abdolrazzagh-Nezhad and Salwani Abdullah, "Job Shop Scheduling: Classification, Constraints and Objective Functions", International Journal of Computer and Information Engineering, 2017.
15. P. Dinakara Prasad Reddy V. C. Veera Reddy and T. Gowri Manohar, "Whale optimization algorithm for optimal sizing of renewable resources for loss reduction in distribution systems", Springer, 2017.
16. Mohamed Abdel-Basset<sup>1</sup> & Doaa El-Shahat<sup>2</sup> & Ibrahim El-henawy<sup>2</sup> & Arun Kumar Sangaiah<sup>3</sup> & Syed Hassan Ahmed," A Novel Whale Optimization Algorithm for Cryptanalysis in Merkle-Hellman Cryptosystem", Mobile Networks and Applications, 2018.