

Impact of Information and Communication Tools in Enhancing the Students Performance in Exams

M. Sankar, W. Porselvi, Sumathy Arjunan

Abstract: The purpose of the present paper is to identify the role of A Study on ICT and Students' performance management Students performance. The factors of student's performance such as ICT (exogenous variable) and Students performance (Endogenous variable) are measured. The endogenous item is students' perception is measured as single.

Method:

Overview strategy was utilized in the examination to gather the information; Structured Questionnaire was disseminated to 115 respondents of understudies (male and female). 15 Questionnaires were seen as unfilled so complete 100 respondents (n=100). CFA and SEM were the measurable devices applied for the examination in AMOS-21 to check the speculation of learn.

Findings:

The study is portraying on positive and significant relation among the exogenous is level of academic challenge and the endogenous is students' performance.

Suggestion:

The results display on the paper level of academic challenge and students perception.

Limitations:

Time period is another factor limitation for the study. Hence findings cannot be generalized.

Key words – students' performance, ICT

I. INTRODUCTION

In this study we had to concentrate the level of university smart class like ICT and students perception. Most of the studies to explain students' perception to measure the

examination like GPA. The integer knowledge and skill oriented study and college environment and play for students games for the example of volleyball, athletics, and cricket to refresh our mind. The primary role of theory to concentrate for play a vital role for better living (Battle & Lewis, 2002).

The company to expect more than output for our company role, maximum product for maximum gain to increase national economic (Saxton, 2000). The factors that influence most of the researcher to follow for respondents details

(Gender, age, education, family income, Parents education) (Crosnoe, Johnson & Elder, 2004). The proper

Revised Manuscript Received on December 30, 2019.

M. Sankar, Assistant Professor, Department Of Science and Humanities, Bharath Institution Of Higher Education And Research. Email: sankar06.phd@gmail.com

W. Porselvi, Assistant Professor, Department Of Science and Humanities, Bharath Institution Of Higher Education And Research. Email: porselviwilson@gmail.com

T. Sumathy Arjunan, Assistant Professor, Department Of Science and Humanities, Bharath Institution Of Higher Education And Research. Email: sumi.renu@gmail.com

role of this demographic factors in 18th century (Mann, 1985). These commonly classify the Umbrella of demography (Ballatine, 1993). The most of the talent persons to explain that socio-economic concentrate students' perception to measures for economic. Well being today economic one of the powerful and basic needs of human wants (Adams, 1996). The economically weak students low results for our recognitions (US Department of Education, 2003). [1]-[4]

Articulation of the issue

Numerous scientists broke down understudy's introduction (execution) by GPA and CGPA was found. In this articles pursued by Grade point esteem. A few analysts to analyzing the quarterly, half yearly and every year to gather the student progress in required look into. The point of the present investigation was concentrate understudy's learning and result of the presentation (test results) was determined by GPA.

Calculated Model

A model structure suggested by past study NSSE George Kuh-Sep(2018) model was taken as a base model for the investigation. They are level of scholarly challenge, and understudies' exhibition. The analyst has tried this edge work as survey, appropriated to the understudies of the executives ponders in a University - instruction foundation

II. AUTHOR'S MODEL



Fig.1. Theoretical Model

III. REVIEW OF LITERATURE:

Education is one of the powerful tool in the world most of the country to create awareness about education. Education has changed our knowledge, skills, self confidence, and balance of our economic status to change of learnrs (Tsinidou, Gerogiannis, & Fitsilis, 2010). The define of educational various from country to country culture difference (Michael, 1998). These societal has vital role of goal setting of students perception (Goddard, 2003). The involved social structure mentions that parents concentrate children's education increase the educational achievement of their children (Furstenberg & Hughes, 1995).

The correlation between male and female the educational success of students has been discuss for ten years (Eitle, 2005).



Impact of Information and Communication Tools in Enhancing the Students Performance in Exams

Who are professionally qualified students' female displays better than male performance (Chambers & Schreiber, 2004). Male and female and parents profession are positive contributor to student success (McCoy, 2005; Peng & Hall, 1995). A research study which highlights the opinion of male and female, discusses that female students perform better when compared to male students.[5]-[9]

ICT- Education

ICT one of the most important in the modern world ,the studies published shows that have empirically investigate of the idea on academic performance have emphasized the concept's contextualized nature. Miller and Shih (1999) survey was 262 faculties about their perceptions of the differences in the analogous concept of academic severity levels between on-campus and off-campus courses. At their institution, off-campus courses are delivered electronically, or they are taught traditionally at a site off campus. Their survey characterize academic challenge in several ways: as demanding high achievement (Braxton, 1993), as challenging students to struggle for fineness (Unks, 1979), and as engaging students in active learning. The authors believed, however, that these perceptions alone were not strong enough evidence to suggest that the teaching for rigor was different between the two types of courses. The National Survey of Student Engagement (2012), often referred to as the NSSE, provides higher education institutions with students' reflections on their learning, including academic challenge, and on their participation in education-related programs and activities. [10]-[14]

Students Performance:

Students' performance is the basic concept of schools, college, and University. Students is one of the fundamental asset of university, because the first person of the institution to produced economic under hold on our hand, but student management is basically arts, because each and every student measure the difficult to understand one person to other. Commonly to explain students is most powerful persons because to divide all job only students. Students performance has been measures our knowledge, practical skills, lab skills etc. The most of the educational institution measure only for students' examination like GPA and CGPA. Students' performance has been argued among teacher, employees, and Dean of the institution. Students' perception has been lots of study that sounds good. The previous findings explain work hard, education level of parents, previous university, family income and factors of self motivation have been positive outcome on the students GPA. The study on students' perception measure on GPA. The item that support affect student's performance Academic challenge. The results also show that academic challenge management students' performance is strong support.

Research question:

1. Does level of ICT-Use and performance of students?

Objective of the study:

1. To analyze the association among ICT-use and students' performance.

Hypotheses

H1. There is positive relation among ICT and students' perception.

IV. RESULTS & DISCUSSION

The examination was completed the relationship between level of scholarly challenge and understudies' presentation estimated among 115 administration understudy. The improve of concentrate through poll while in transit to discover the ICT in understudies' exhibition.

A. Testing technique

The respondents of this investigation comprise of Management understudies' at the private college. Review techniques were utilized for the exploration study. The all out number of understudies (male and female) of the understudies' organized Questionnaire was appropriated to 135 respondents of understudies (male and female). 35 Questionnaires was seen as unfilled so all out 100 respondent filled quality poll

Data Analysis Table I. Overall Reliability of the Data

Alpha(α) std. things	Number of things
.87	15

Variables	Cronbach's Alpha	No of Item
Students performance	.899	11
ICT	.977	12

Generally dependability instrument concentrate was 0.837. The present investigation to analyze dependability of the general Item is 0.837 is noteworthy individual alpha (ICT) is 0.977 and subordinate variable Student execution is 0.899 the all in all 0.837.It is worth note that 0.70 ought to be a sufficient alpha worth coefficient still lower coefficients utilized in a couple of research.[16]-[20]

Sample Adequacy Table II. (KMO)

Sample adequacy KMO	.79
Adequacy.	
B T S	1175.769
Degrees of freedom	55
Significance.	0.000

The value received through KMO test was .839 which is over the edge estimation of (0.7). The Chi-square worth was 1175.769, Degrees of opportunity (DF) was 55 and the noteworthy p worth is .000. Consequently the example taken for the investigation is satisfactory in nature.[21]-[24]

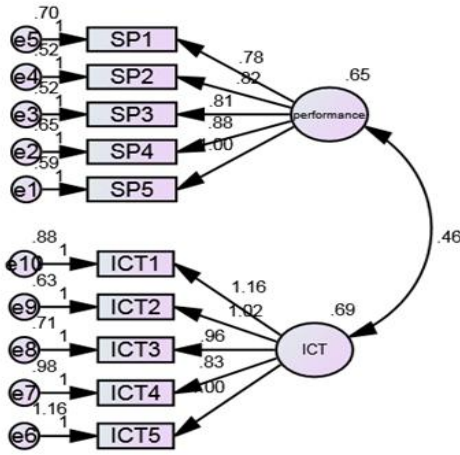

Diagram 1 Showing CFA analysis

Table III

Fit Indices	Results
Chi-square	0.177
CMIN/DF	3.123
P	.000
GFI	0.915
AGFI	0.937
NFI	0.940
TLI	0.939
CFI	0.973
RMSEA	0.057

Table IV showing testing of Hypothesis

Variables	The relation	Hypothesis
ICT	Students performance	Supported

The tested hypothesis as per regression analysis proves to be significant.

Path Analysis

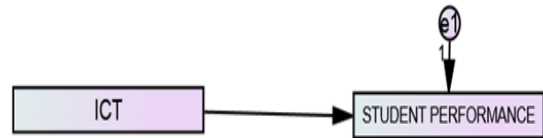

Diagram 2 Showing path analyses

Discussion:

The path analysis done using SEM analysis has helped to Identified the model. The values GFI= 1.00, CFI=1.00, RMSEA=.0453 confirmed that level of academic challenge has on effect over the students' academic performance.

V. CONCLUSION

This examination was conveyed to clarify the job of level of scholarly challenge and the factors do assume an indispensable job in the understudies' exhibition. Level of scholarly challenge has been one of the feeble regions in the field of Indian training, however it has begun to pick up force. Future examines with more intercession factors like sex and GPA can be utilized

REFERENCES

- Vasanthi, S. & Rabiyaathul Basariya, S. 2019, "Influence of value analysis and cross training in industry", *International Journal of Engineering and Advanced Technology*, vol. 8, no. 6, pp. 1810-1811.
- Velvizhi, R., Sri Gowtham, S. & Jeya Priya, D. 2019, "Examination of early feedbacks for effective product retailing on E-commerce websites", *International Journal of Engineering and Advanced Technology*, vol. 8, no. 6 Special Issue 2, pp. 703-706.
- Anuradha, C., Pothumani, S. & Kavitha, R. 2019, "A novel method towards E-commerce", *International Journal of Engineering and Advanced Technology*, vol. 8, no. 6 Special Issue 2, pp. 535-538.
- Thomas, J. & Rabiyaathul Basariya, S. 2019, "A study on the issues of financial ratio analysis", *Indian Journal of Public Health Research and Development*, vol. 10, no. 3, pp. 1079-1081.
- Ramachandran, S. & Rabiyaathul Basariya, S. 2019, "Online marketing - study on customer satisfaction and relationship", *Indian Journal of Public Health Research and Development*, vol. 10, no. 3, pp. 1072-1078.
- Priya, R., Vinothini, G. & Cor Jesu, C.D. 2019, "The mentor-protégé relationship for professional growth", *Journal of Advanced Research in Dynamical and Control Systems*, vol. 11, no. 9 Special Issue, pp. 1110-1119.
- Jannifer Rani, N., Bina Pani, S. & Nimisha, N.S. 2019, "A study on money back polices available in LIC", *Journal of Advanced Research in Dynamical and Control Systems*, vol. 11, no. 9 Special Issue, pp. 833-839.
- Saillaja, V., Jhansi Rani, K. & Catherine, R. 2019, "Global marketing management planning and organization", *Journal of Advanced Research in Dynamical and Control Systems*, vol. 11, no. 9 Special Issue, pp. 489-493.

9. Saillaja, V., Jhansi Rani, K. & Catherine, R. 2019, "The new phase of marketing information system", *Journal of Advanced Research in Dynamical and Control Systems*, vol. 11, no. 9 Special Issue, pp. 482-488.
10. Thoufiqulla & Raju, D.V. 2019, "Perception of indian investor towards investment in mutual funds with special reference to mip funds", *Journal of Advanced Research in Dynamical and Control Systems*, vol. 11, no. 5, pp. 177-183.
11. Jasmine, K.R.M. & Basariya, S.R. 2018, "A study on the customers benefits on mutual funds", *International Journal of Civil Engineering and Technology*, vol. 9, no. 4, pp. 45-48.
12. Vasanthi, S. & Basariya, S.R. 2019, "Pros and cons of on the job training versus off the job training", *International Journal of Scientific and Technology Research*, vol. 8, no. 10, pp. 671-674.
13. Pavithra, J. & Ganesan, M. 2016, "A study on awareness and impact of micro-financial schemes", *International Journal of Applied Business and Economic Research*, vol. 14, no. 8, pp. 5449-5460.
14. Pavithra, J., Dilli Babu, P. & Ambuli, T.V. 2014, "A study on budgetary control at Maruti Service Masters, Chennai", *International Journal of Applied Business and Economic Research*, vol. 12, no. 2, pp. 151-161.
15. Gunaraja, T.M. & Venkatrama Raju, D. 2018, "Determining factors of organisational climate with reference to leadership styles", *International Journal of Mechanical Engineering and Technology*, vol. 9, no. 9, pp. 1327-1332.
16. Gunaraja, T.M. & Venkatrama Raju, D. 2018, "The role of job satisfaction and training of employees in determining organisational climate of a selected industry", *International Journal of Civil Engineering and Technology*, vol. 9, no. 8, pp. 1266-1269.
17. Aarathy, T.S. & Raju, D.V. 2018, "Performance appraisal and its effects on employees with respect to it sector in Chennai city", *International Journal of Civil Engineering and Technology*, vol. 9, no. 6, pp. 1535-1538.
18. Aarathy, T.S. & Raju, D.V. 2018, "Employee perception towards performance appraisal system in IT sector", *International Journal of Mechanical Engineering and Technology*, vol. 9, no. 5, pp. 131-135.
19. Porselvi, W., Jublee, D. & Sivanesan, G. 2018, "A study on factors influencing adoption of technology and innovation in banking industry, tamilnadu, India", *International Journal of Mechanical Engineering and Technology*, vol. 9, no. 5, pp. 789-800.
20. Akessa, G.M. and Dhufera, A.G., 2015. Factors That Influences Students Academic Performance: A Case of Rift Valley University, Jimma, Ethiopia. *Journal of Education and Practice*, 6(22), pp.55-63.
21. Miller, G. and Shih, C.C., 1999. A faculty assessment of the academic rigor of on-and off-campus courses in agriculture. *Journal of Agricultural Education*, 40, pp.57-65.
22. Tsinidou, M., Gerogiannis, V. and Fitsilis, P., 2010. Evaluation of the factors that determine quality in higher education: an empirical study. *Quality Assurance in education*, 18(3), pp.227-244.
23. Farooq, M.S., Chaudhry, A.H., Shafiq, M. and Berhanu, G., 2011. Factors affecting students' quality of academic performance: a case of secondary school level. *Journal of quality and technology management*, 7(2), pp.1-14.
24. Fitsilis, P., Gerogiannis, V. and Anthopoulos, L., 2014. Ontologies for software project management: a review. *Journal of Software Engineering and Applications*, 7(13), p.1096.
25. Adams, J.D. and Jaffe, A.B., 1996. *Bounding the effects of R&D: an investigation using matched establishment-firm data*(No. w5544). National bureau of economic research

AUTHORS PROFILE



M. Sankar, Assistant Professor, Department Of Science and Humanities, Bharath Institution Of Higher Education And Research



W. Porselvi, Assistant Professor, Department Of Science and Humanities, Bharath Institution Of Higher Education And Research



T. Sumathy Arjunan, Assistant Professor, Department Of Science and Humanities, Bharath Institution Of Higher Education And Research.