

IOT Based Smart Agriculture Monitoring System



Yash Sharma, Vishudeep Tyagi, Priyanka Datta

Abstract: In old Days Farmers was very interested to figure out the fertility of soil and impact on feeling to grow which to quite yield. They brought some thoughts which leads to detect humidity level water level climatic condition with the help of internet of things (IOT) which is redesigning the farming sector through the wide range of strategies, as an example accuracy furthermore as practical farming to house challenging within farming sector. The application of IOT helps in gathering of information which is quietly helpful in farming sector like changing in climatic condition fertility of soil, amount of water needed for crops, bug location interruption of creature to the sphere, horticulture, IOT helps farmers to proper utilize the technology together with the information with his residence from wherever and at whatever point. Different types of sensors are used for the inspection and control of the crop which are very significant under their precise output and use. cameras are used for remotely monitoring the field. IOT technology helps in best crop management, increase in productivity and reduce the trouble of farmer as compared to normal farming.

Keywords: moisture sensor, Water level sensor, Humidity sensor, Temperature sensor, IOT.

I. INTRODUCTION

Farming is a main income source for the most of India's population and has significant contributions to the economy of India during the last decade. It is significant to mention that crop production in the agriculture sector does not appear to be significant. Food prices are rising continuously due to declining crop rates.

There are a lot of factors that are charged for this, like wastage of water, less fertility in the soil, misuse of fertilizers, global climate change or diseases etc.

Developing appropriate interventions in agriculture is absolutely essential. So, the solution is integration of IOT and Wireless Sensor Network Integration.

Internet of things (IOT) is a way of connecting everything to the internet i.e. it's connecting objects or things (such as showrooms, homes, electronic devices, etc. ...) that's not connected to each other before.

Revised Manuscript Received on July 30, 2020.

* Correspondence Author

Yash Sharma*, EEE Department, G L Bajaj Institute of Technology and Management, Greater Noida, U.P., India, E-mail: yashsharma1998.gl@gmail.com

Vishudeep Tyagi, department, *, EEE Department, G L Bajaj Institute of Technology and Management, Greater Noida, U.P., India, E-mail: vtvisu27@gmail.com

Priyanka Datta, EEE Department, G L Bajaj Institute of Technology and Management, Greater Noida, U.P., India, E-mail: priyankameta.86@gmail.com

© The Authors. Published by Blue Eyes Intelligence Engineering and Sciences Publication (BEIESP). This is an open access article under the CC BY-NC-ND license (<http://creativecommons.org/licenses/by-nc-nd/4.0/>)

IOT's main goal is to ensure the correct information is sent to the right people at the right time. Irrigation is by far the most important factor in agriculture, as the monsoon rainfall is unpredictable and uncertain.

Need of automatic irrigation:

- Quick and easy to put in and configure.
- To save power, resources and time, it is often used in the right way and in the right manner.
- Farmers would be ready by automatic irrigation to provide correct water quantity at the right time.
- Reduce runoff from overwatering saturated soils which can increase crop productivity by avoiding irrigation at the incorrect time of day.
- Automated irrigation system uses motor valves to display an ON and OFF. Motors are often easily automated with the use of controllers and no labour needed to turn the motor ON or OFF.
- It is a precise irrigation method and valuable tool for appropriate control of moisture of soil in highly specialized production of greenhouse vegetable.
- It is time saving and it eliminate human error in adapting the available levels of soil moisture.

The paper utilizes IOT based techniques in farming collecting environmental parameters for crop growth in an extremely fixed location to help the farmers find their problem as soon as possible. Agriculture experts provide guidance with appropriate information on how to improve the income of farmers and help them to prevent and reduce damage of crops from pests and diseases. By the technological development of phone applications, it is introduced with the promotion of agricultural technology and online expert frequently asked questions. System development consists of three parts: the server, Android client and PC client to realize scalability, highly reliable, security, technical requirement compatibility.

II. LITERATURE SURVEY

Various experts and professors make a detailed study on the productivity of the smart farming project.

Patil K. A et al. (2016) [6], present the smart farming project in combination with ICT. ICT always indulges in farming sector. during time, climatic condition and field productivity and growth of pests cause damage to crop and diseases changed, cumulative data sharing helps the farmers to increase productivity from these changes. It is difficult task which have to give such information because of wise agriculture information system which is located at different locations in nature. The present climatic condition and past data of climate helps in monitoring the project. The problem lies which is to make convenient connection of wireless sensors and use them in proper manner.



IOT Based Smart Agriculture Monitoring System

Shakthipriya N et al. (2014) [7], as referred she study the technology of various sensors in farming. Depending the data recorded by the moisture sensor inserted into the soil the water sprinkler works during water scarcity.

Once crop is sprinkled with a significant amount of water the sprinkler then turned off. Hence water may be conserve. Also, GSM modem is used to receive data of pH value of soil via SMS. A problem lies with it and that's it gives precision value which is not actually value and which is not cost efficient.

G. Meena Kumari et al. (2014) [4], she approaches technical development in the field of Wireless Sensor Networks made it possible to use in monitoring, control and inspection of greenhouse parameter in precise agriculture system. the data transfer is primarily controlled by hybrid system.

III. PROPOSED WORK

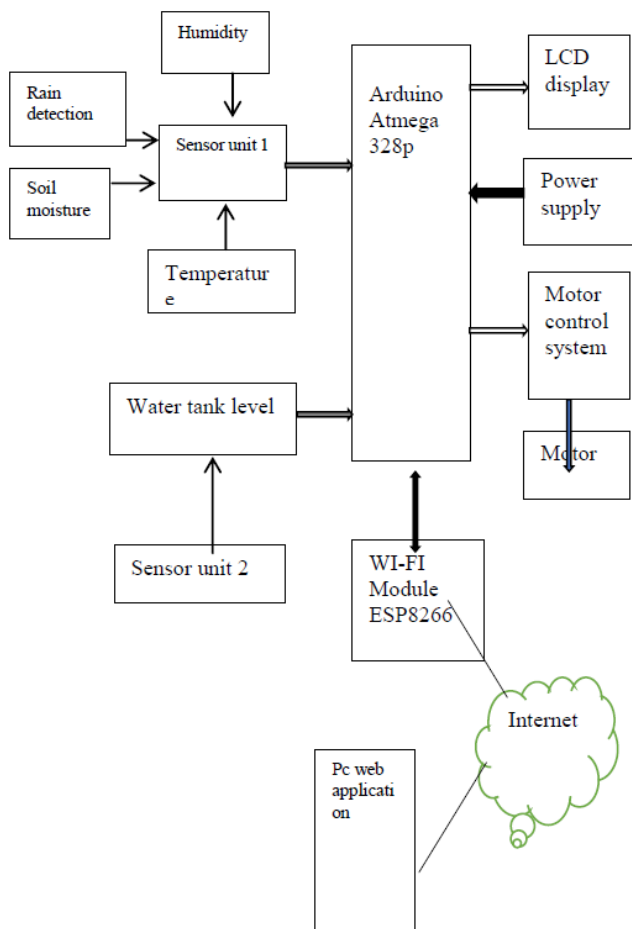

Fig1. Block Diagram Proposed Work

- 1) Sensor data acquisition: -
Interfacing of sensors is done with the Arduino. sensors like temperature, humidity, moisture and rain detection sensors
- 2) Wireless info transmission: -
Info gained from the operation of various sensors is transferred through online web server.
- 3) processing and Decision making: -
There are various sensors used in the field for various processes. during processes of sensors data received by the sensors and decision is made based on the received data. which is compared with the threshold values.

The automated irrigation system is based on the soil moisture sensor. When the moisture level falling the threshold value water pump is turned on.

- 4) Automatic water pump system: -
Once the automated water pump system receives and transfer the information to and from the mobile software. The Arduino microcontroller helps in controlling electrical switches and hold control of switches and relays using an online software. Relay control circuits which are low power signalled.
- 5) Web application: -
A software is designed by using internet connectivity which is used to observe the crop from anywhere. Processing IDE is employed to control the Arduino, the processing IDE is used to communicate with the web server and web page.
- 6) Mobile Application: -
Android software is developed which can be used on the mobile phones for monitoring the crop from anywhere. The android software helps in controlling the various sensors in the field.

IV. HARDWARE USED

- 1) Moisture Sensor: - The moisture present in soil is detected by this soil moisture sensor. Both analog and digital output can be accessed by the sensor. the analog output is varying so the threshold output is varied. The digital I/O is compared according to the threshold values. The working principal depends upon the open and short circuits. The LED is used to indicate the output which is high or low it depends. the current won't pass when the soil is dry therefore it'll act as electric circuit. Hence large output is observed. The soil moisture as two probe which is used for measuring the moisture level in pot or yard. The two probe allows the current to pass through the soil and gets the resistance value to measure the moisture level.

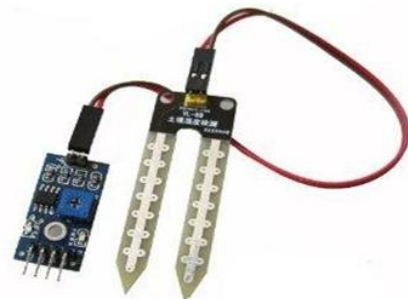

Fig2. Soil moisture sensor

- 2) Temperature Sensor: - Due to the output voltage which is linear with the Celsius scaling of temperature we use The LM35 sensor. This sensor has a very large operating rang. The most probably output is 5V. for each one degree rise in temperature the output may increase to 10 mV. The LM35 device is rated to operate over a -55 degrees to +150 degrees temperature range. it has three pins namely vcc, analog out ground. It is very efficient in electricity consumption as it consumes less electricity.

User will take controlling action consistent with that this may be done by using actuator. This asset allows the farmer to boost the cultivation during a way the plant need.

It results in higher crop yield, prolonged production period, better quality and fewer use of protective use of protective chemicals.

REFERENCES

1. Rajalakshmi.P, Mrs. Devi Mahalakshmi “IOT Based Crop-Field Monitoring and Irrigation Automation” 10th International conference on Intelligent systems and control (ISCO), 7-8 Jan 2016 published in IEEE Xplore Nov 2016.
2. Prof. K. A. Patil and Prof N. R. Kale propose “A Model for Smart Agriculture Using IOT” 2016 International Conference on Global Trends in Signal Processing, Information Computing and Communication.
3. Dr.N. Suma, Sandra Rhea Samson, S. Saranya, G. Shanmugapriya, R. Subhashri „IOT Based Smart Agriculture Monitoring System” 2017 International Journal on Recent and Innovation Trends in Computing and Communication.
4. Mahammad shareef Mekala, Dr.P. Viswanathan „A Survey: Smart agriculture IoT with cloud computing” 978-1-5386-1716-8/17/\$31.00 ©2017 IEEE.
5. Prathibha S R1, Anupama Hongal 2, Jyothi M P3” IOT BASED MONITORING SYSTEM IN SMART AGRICULTURE” 2017 International Conference on Recent Advances in Electronics and Communication Technology.
6. Ibrahim Mat, Mohamed Rawidean Mohd Kasim, Ahmad Nizar Harun, Ismail Mat Yusuf “IOT in Precision Agriculture Applications Using Wireless Moisture Sensor Network” 2016 IEEE Conference on Open Systems (ICOS), October 10-12- 2016, Langkaw, Malaysia.
7. Zhao Chan Li, JinlongWang, Russell Higgs, LiZhou WenbinYuan4 “Design of an Intelligent Management System for Agricultural Greenhouses based on the Internet of Things” IEEE International Conference on Embedded and Ubiquitous Computing (EUC) 2017.

AUTHORS PROFILE



Yash Sharma is doing his final year B.tech (EN) from G.L Bajaj Institute of Technology and Management, Greater Noida, U.P, India. His final project is “Iot based smart agriculture monitoring system”.



Vishudep tyagi is doing his final year B.tech (EN) from G.L Bajaj Institute of Technology and Management, Greater Noida, U.P, India. His final project is “Iot based smart agriculture monitoring system”.



Priyanka Datta received her B.tech degree in Electronics and Communication from UPTU, Lucknow. She received her M.tech degree in Electronics and Communication from JIIT, Noida. Currently, she is pursuing PhD from DTU (Formerly DCE), Delhi. Since 2011, she has been working as Assistant Professor with G

L Bajaj Institute of Technology and Management, Greater Noida, U.P., India. Her current area of interest is machine learning, image processing, signal processing, medical imaging.